

This article was downloaded by: [Izmir Yuksek Teknoloji Enstitusu]

On: 22 March 2013, At: 09:26

Publisher: Taylor & Francis

Informa Ltd Registered in England and Wales Registered Number: 1072954 Registered office: Mortimer House, 37-41 Mortimer Street, London W1T 3JH, UK



## International Journal of Crashworthiness

Publication details, including instructions for authors and subscription information:  
<http://www.tandfonline.com/loi/tcrs20>

### Projectile impact testing of glass fiber-reinforced composite and layered corrugated aluminium and aluminium foam core sandwich panels: a comparative study

İsmet Kutlay Odacı<sup>a</sup>, Cenk Kılıçaslan<sup>a</sup>, Alper Taşdemirci<sup>a</sup> & Mustafa Güden<sup>a</sup>

<sup>a</sup> Dynamic Testing and Modeling Laboratory, Department of Mechanical Engineering, Izmir Institute of Technology, Izmir, Turkey

Version of record first published: 23 May 2012.

To cite this article: İsmet Kutlay Odacı, Cenk Kılıçaslan, Alper Taşdemirci & Mustafa Güden (2012): Projectile impact testing of glass fiber-reinforced composite and layered corrugated aluminium and aluminium foam core sandwich panels: a comparative study, International Journal of Crashworthiness, 17:5, 508-518

To link to this article: <http://dx.doi.org/10.1080/13588265.2012.690215>

PLEASE SCROLL DOWN FOR ARTICLE

Full terms and conditions of use: <http://www.tandfonline.com/page/terms-and-conditions>

This article may be used for research, teaching, and private study purposes. Any substantial or systematic reproduction, redistribution, reselling, loan, sub-licensing, systematic supply, or distribution in any form to anyone is expressly forbidden.

The publisher does not give any warranty express or implied or make any representation that the contents will be complete or accurate or up to date. The accuracy of any instructions, formulae, and drug doses should be independently verified with primary sources. The publisher shall not be liable for any loss, actions, claims, proceedings, demand, or costs or damages whatsoever or howsoever caused arising directly or indirectly in connection with or arising out of the use of this material.

## Projectile impact testing of glass fiber-reinforced composite and layered corrugated aluminium and aluminium foam core sandwich panels: a comparative study

İsmet Kutlay Odacı, Cenk Kılıçaslan, Alper Taşdemirci and Mustafa Güden\*

*Dynamic Testing and Modeling Laboratory, Department of Mechanical Engineering, Izmir Institute of Technology, Izmir, Turkey*

*(Received 8 February 2012; final version received 30 April 2012)*

E-glass/polyester composite and layered corrugated aluminium and aluminium foam core sandwich panels were projectile impact tested between 127 m/s and 190 m/s using a hardened steel sphere projectile. The corrugated aluminium cores, constructed from aluminium fin layers and aluminium interlayers and face sheets, exhibited relatively lower-plateau stresses and higher stress oscillations in the plateau region than aluminium foam cores. The applied brazing process resulted in reductions in the plateau stresses of the corrugated aluminium cores. The sandwich panels with 2- and 3-mm-thick composite face sheets and the epoxy-bonded corrugated aluminium sheet cores were perforated, while the sandwich panels with 5-mm-thick composite face sheets were penetrated in the projectile impact tests. On the other hand, the sandwich panels with aluminium foam cores were only penetrated. A simple comparison between the ballistic limits of the sandwich panels as a function of total weight revealed significant increases in the ballistic limits of the cores with the inclusion of composite face sheets. The determined higher impact resistance of the foam core sandwich panels was attributed to the relatively higher strength of the foam cores investigated and the ability to distribute the incident impulse to a relatively large area of the backing composite plate.

**Keywords:** sandwich panels; corrugated aluminium; aluminium foam; projectile impact

### 1. Introduction

The sandwich panels based on fiber-reinforced composites and/or sheet metals have become increasingly important in designing light-weight structures. Typical applications include the structural parts in airplanes, automobiles, ships, wind turbines and bridges. A sandwich panel comprises a light-weight core and a hard facing layer usually made of a fiber-reinforced composite and/or a sheet metal. The core provides stiffness to the panel and absorbs the deformation energy under impulse loading. The distinguished physical and mechanical properties of aluminium closed-cell foams, including low density, progressive folding until about large strains, relatively constant and/or slowly increasing plateau stresses and deformation energy absorption capabilities [2,5,7], make them very suitable core materials for sandwich panel construction. Hou et al. [9] investigated the quasi-static and impact responses of a Cymat closed-cell aluminium foam sandwich panel against flat, hemispherical and conical stainless steel projectiles. The dynamic perforation energy of the sandwich panel was shown higher than the quasi-static perforation energy. Thicker face sheets and cores resulted in higher ballistic limits and larger delamination areas between the core and the rear face, while blunter projectiles resulted in larger petalling area and tended to increase the ballistic limits and energy dissipation.

Reyes-Villanueva and Cantwell [15] studied the impact response of Alporas closed-cell aluminium foam core sandwich panels with unidirectional glass fiber/polypropylene and stacked (hybrid) glass fiber/polypropylene composite and aluminium 2024T3 face sheets. Hybrid sandwich panels were shown to exhibit higher specific perforation energies than plain composite sandwich panels. Hanssen et al. [8] applied experimental and numerical bird-strike tests on aluminium foam sandwich panels.

Light-weight corrugated structures offer a variety of geometries and have several important advantages over metal foams, including regular and homogeneous cellular structure providing a higher level of reliability in structural applications and ease of processing into intricate geometries. Liang et al. [11] analysed the effect of certain geometrical parameters on the buckling and axial strength of corrugated sandwich panels subjected to a uniformly distributed pressure pulse. McShane et al. [12] and Rathburn et al. [14] investigated the dynamic impact response of square honeycomb core sandwich plates against aluminium foam projectiles. Square honeycomb cores were shown to exhibit smaller displacements than the equal-mass solid steel beams. It was also reported that the dynamic strengths of honeycomb cores exceeded the quasi-static strengths by a factor of 2–4. Tilbrook et al. [19] investigated the front- and

\*Corresponding author. Email: mustafaguden@iyte.edu.tr

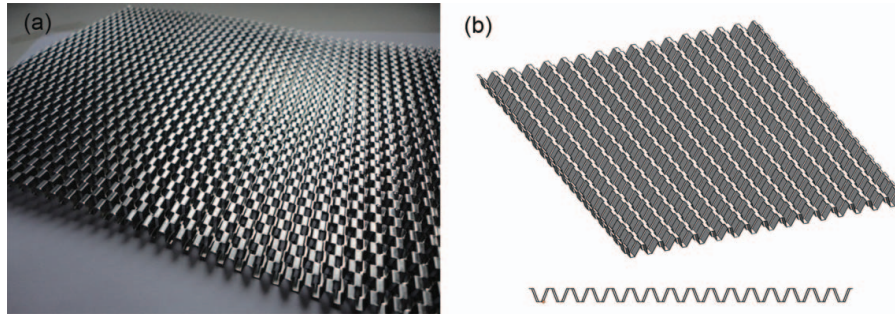

Figure 1. (a) Corrugated aluminium sheet layer and (b) 3D model.

rear-face stresses of dynamically compressed corrugated and Y-frame cores using a modified impact test in a split Hopkinson pressure bar. The micro-inertial stabilisation of both topologies against elastic buckling was observed until about  $30 \text{ m s}^{-1}$ , while at increasing displacement rates, the front-face stress increased and the rear-face stress remained constant. Rubino et al. [16,17] investigated the impact response of fully clamped 304 stainless Y-frame and corrugated core sandwich panels of equal areal mass. The sandwich panels were perforated at higher projectile velocities, while monolithic plates remained intact within the studied projectile velocities. Monolithic plates also showed larger deflections than sandwich panels. Radford et al. [13] studied the dynamic response of end-clamped monolithic stainless steel and austenitic stainless steel sandwich beams against metal foam projectiles. Sandwich beams exhibited higher shock loading resistance than monolithic beams at the same mass and equal projectile incident momentum.

Despite quite a number of studies on the projectile impact behavior of corrugated aluminium sandwich panels, no comparison has been made between the impact responses of layered corrugated aluminium and aluminium foam core sandwich panels. In this study, E-glass/polyester composite/layered corrugated aluminium and aluminium foam core sandwich panels and the monolithic composite plates and cores were projectile impact tested using a spherical steel projectile at similar impact velocities. The responses of corrugated aluminium and aluminium foam sandwich panels and monolithic face sheets and cores were compared based on the impact damage and the ballistic limits as a function of total weight.

## 2. Materials

### 2.1. Composite plates

E-glass woven fabric (Metyx)/Crystic PAX 702 polyester composites face sheets, in 2-, 3- and 5-mm thicknesses with  $0^\circ/90^\circ$  fiber orientations and 0.6 fiber volume fraction were prepared using a vacuum-assisted resin transfer moulding (VARTM). Methyl ethyl ketone peroxide was used as hardener with an amount of 2 wt%.

### 2.2. Cores

The corrugated aluminium core panels were constructed by stacking (i) trapezoidal corrugated aluminium sheets (fin layer), (ii) aluminium sheet interlayers and (iii) aluminium face sheets. Corrugated 1050H14 aluminium sheets shown in Figure 1(a) and (b) are currently used in conventional heat exchangers and were received from a local radiator factory. These sheets (layers) were produced through a sheet-forming process in which a paired punch and die tools deform aluminium sheets into regular trapezoidal shapes, leading to highly flexible structures. It should be noted that the investigated fin geometries are optimised for heat transfer, not for deformation energy absorption. The corrugated aluminium core panels were assembled by means of epoxy bonding and brazing. Before brazing, the assembly passed through a cleaning and fluxing process. The brazing was performed at  $600^\circ\text{C}$  (10 min) using an aluminium 4343 alloy (6.8–8.2 wt%) as filler. The model structures of the corrugated core and the unit fin are shown Figure 2. Corrugated core panels constructed from 9-mm-thick fin sheets (Figure 2) were called as big fin corrugated panel and were assembled by means of epoxy bonding and brazing. The brazed big fin core panels (relative density = 0.13) were made of 3003 aluminium face sheets and 1050H14 aluminium interlayers, while epoxy-bonded big fin core panels (relative density = 0.12) were made of 1050H14 face sheets and 1050H14 interlayers. Small fin corrugated core panels were constructed using 4-mm-thick fin sheets (relative density = 0.24) and assembled by brazing. These cores were made of 1050H14 aluminium face sheets and interlayers. Both big and small fin corrugated cores comprised seven corrugated sheets (0.135-mm-thick), six interlayer sheets (0.5-mm-thick) and two aluminium face sheets (2-mm-thick), as depicted in the figure. The weights of the brazed big and small fin corrugated core panels ( $200 \times 200 \text{ mm}^2$ ) were 1025 and 925 g, respectively. The weight of epoxy-bonded big fin corrugated core panels ( $200 \times 200 \text{ mm}^2$ ) was approximately 800 g, lighter than the brazed counterparts.

Alulight AlSi10 closed-cell foam panels ( $625 \times 625 \times 30 \text{ mm}^3$ ) were received in two densities: 297 and  $405 \text{ kg/m}^3$ , corresponding to 0.11 and 0.15 relative densities,

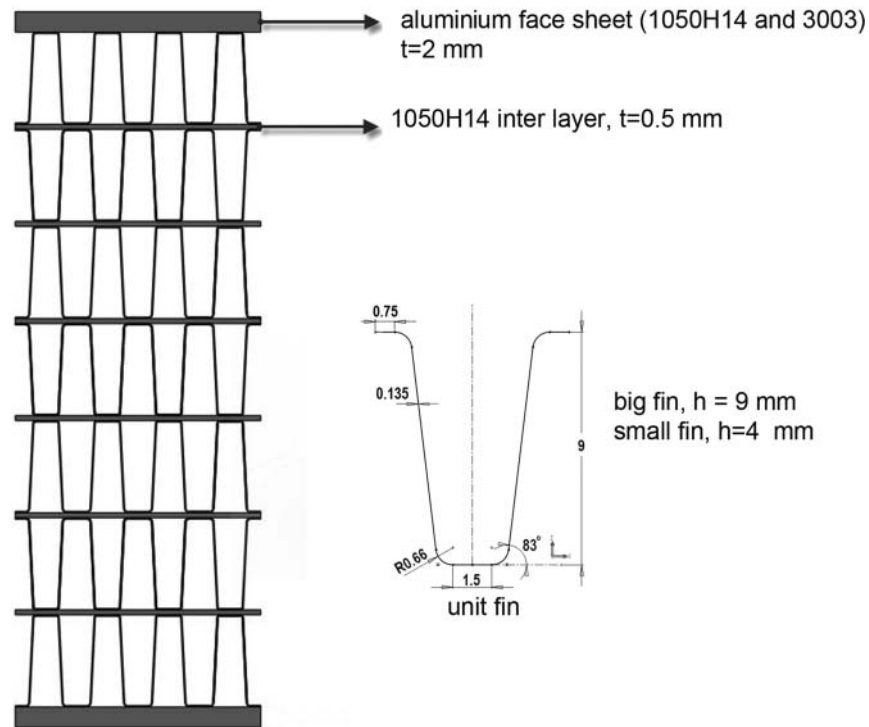

Figure 2. Two-dimensional model and layer structure of corrugated aluminium core and unit fin structure.

respectively. The foam cores for sandwich panel construction and impact testing were cut in  $200 \times 200 \text{ mm}^2$  cross-section from the as-received panels. Detailed information about the compression properties of the investigated aluminium foams and tension properties of 1050H14 alloy are given elsewhere [20].

### 2.3. Sandwich panels

Corrugated aluminium sandwich panels were constructed using epoxy-bonded big fin corrugated aluminium core panels (Figure 3(a)). The composite face sheets were epoxy-bonded to the faces of corrugated aluminium core panels under a 20-kg weight for 2 h. The prepared big fin corrugated aluminium core panel and the composite sandwich

panel with 5-mm-thick composite face sheets are shown in Figure 3(a) and (b), respectively. The thicknesses of big fin corrugated aluminium sandwich panels with 2-, 3- and 5-mm-thick composite face sheets were 74, 76 and 80 mm, respectively.

Aluminium foam composite sandwich panels with 0.11 and 0.15 relative densities were prepared by VARTM. In this process, face sheets fabrics and aluminium core were resin-infiltrated in a single steep, as depicted in Figure 4(a). The thickness of aluminium foam sandwich panels with 2-, 3- and 5-mm-thick composite face sheets were 34, 36 and 40 mm, respectively. The prepared foam sandwich panels are shown in Figure 4(b). Since the surfaces of the foam cores were covered with a dense skin layer, no resin infiltration occurred during VARTM through the interior of the foam cores.

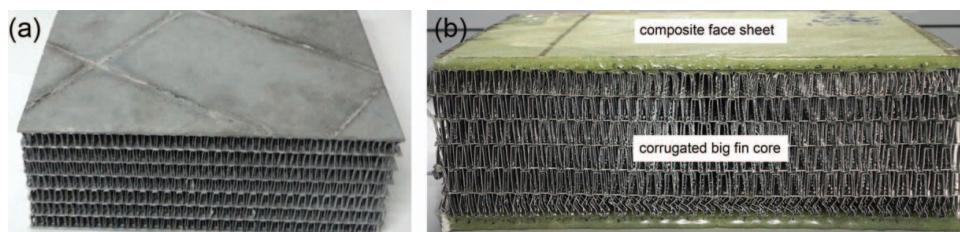

Figure 3. (a) Big fin corrugated aluminium core panel and (b) big fin corrugated aluminium composite sandwich panel.

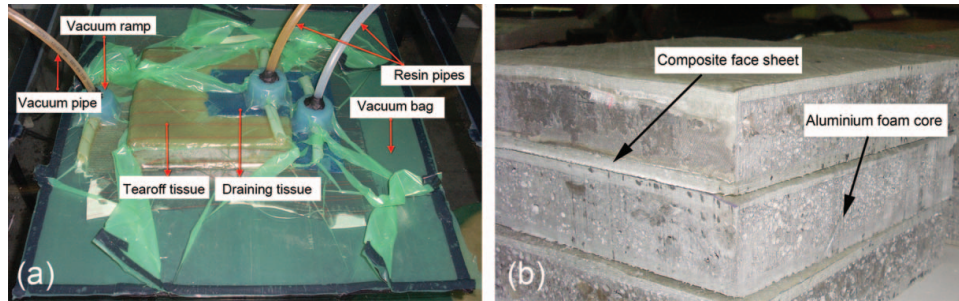

Figure 4. (a) VARTM set-up and (b) composite sandwich panels with aluminium foam core.

### 3. Experimental

#### 3.1. Quasi-static testing of composite face sheets and cores

E-glass/polyester composite tensile test samples were prepared in accordance with the ASTM 3039M standard [18]. The width, length and thickness of the test samples were 25, 250 and 2.5 mm, respectively. Tests were performed using a Shimadzu universal displacement controlled test machine at a crosshead speed of 2 mm/min through warp and weft directions. A video extensometer connected to the test machine was used to measure axial strain.

The compression testing of cores were performed using rectangular test samples; the sizes of the tested samples were sequentially  $50 \times 50 \times 70 \text{ mm}^3$  and  $50 \times 50 \times 32 \text{ mm}^3$  for big fin (Figure 5(a)) and small fin corrugated aluminium and  $50 \times 50 \times 30 \text{ mm}^3$  for aluminium foam (Figures 5(b)). Compression tests were performed at a strain rate of  $1 \times 10^{-3} \text{ s}^{-1}$ . At least three tensile or compression tests were performed on each group of samples.

#### 3.2. Projectile impact testing of face sheets, cores and sandwich panels

The projectile impact tests on composite plates, corrugated aluminium and foam core panels and composite sandwich panels were performed using a pneumatic gas gun assembly, as shown in Figure 6(a). The gas gun assembly consisted of a pressure vessel, triggering valve, sabot, gun barrel and target chamber. The projectile was guided in the gun barrel by means of a polyurethane foam sabot (18 g) (Figure 6(a)). The pressure vessel fired the projectile against the target, which was clamped on the target frame inside the target chamber (Figure 6(b)). The incident and residual projectile velocities were measured with the laser barriers in the target chamber (Figure 6(c)). The projectile was a hardened steel sphere, 30 mm in diameter and 110 g in weight. The incident projectile velocities were altered with the pressure of the vessel and ranged between 127 m/s and 190 m/s. The ballistic limit ( $V_b$ ) of the tested plates and panels was calculated by assuming all kinetic energy loss

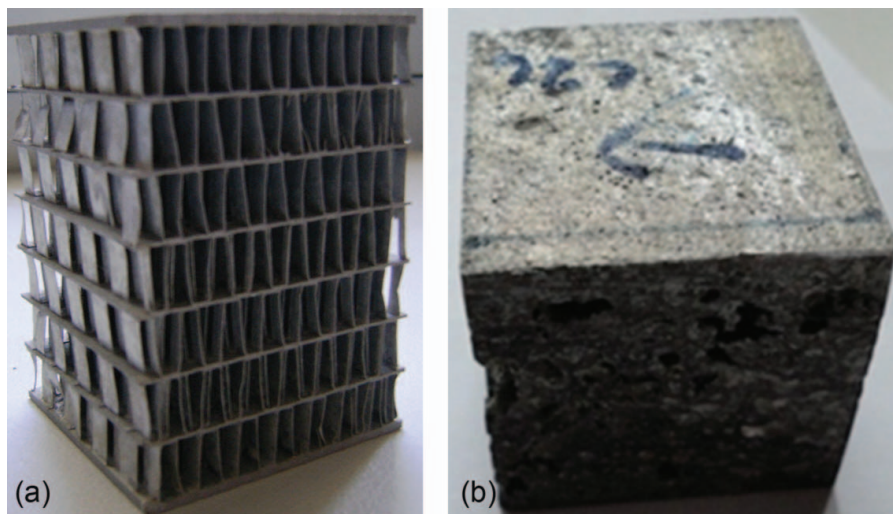

Figure 5. Compression tests samples: (a) corrugated aluminium and (b) aluminium foam.

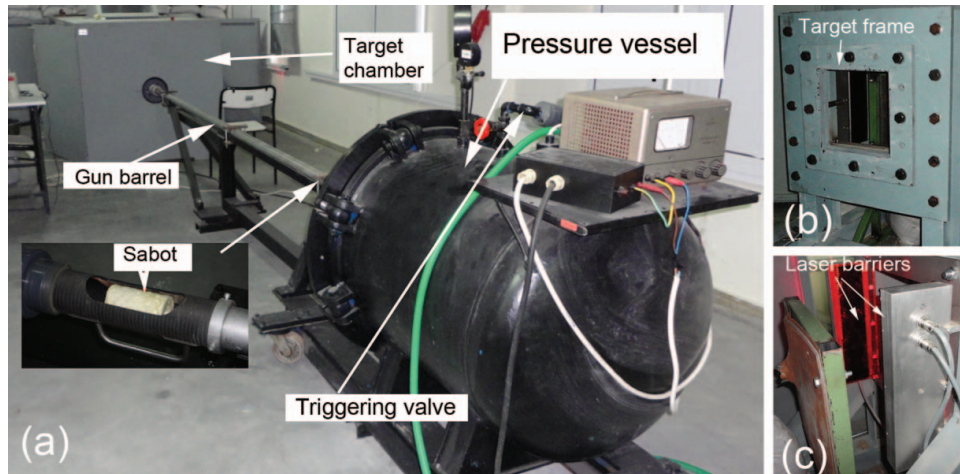

Figure 6. (a) Projectile impact test set-up, (b) target frame and (c) laser barriers.

of the projectile dissipated by the panel as [10]

$$V_b = \sqrt{V_i^2 - V_r^2} \quad (1)$$

where  $V_i$  and  $V_r$  are the incident and residual velocity of projectile, respectively.

Broadly, six groups of materials were projectile impact tested: (i) composite face plates, 2-, 3- and 5-mm thick, (ii) brazed big and small fin corrugated aluminium core panels, (iii) epoxy-bonded big fin corrugated aluminium core panels, (iv) 0.15 relative density aluminium foam core panels, (v) epoxy-bonded big fin corrugated aluminium core/2-, 3- and 5-mm-thick composite face sheet sandwich planes and (vi) 0.11 and 0.15 relative density aluminium foam core/2-, 3- and 5-mm-thick composite face sheet sandwich panels. The tested target plates/panels had the same cross-sectional area,  $200 \times 200 \text{ mm}^2$ .

#### 4. Results and discussion

The quasi-static tensile stress–strain curves of the prepared composite plates in warp and weft directions are very similar, as shown in Figure 7(a). The average quasi-static tensile strength, elastic modulus and tensile failure strain were determined as 410 MPa, 16 GPa and 0.0247, respectively. Similar tensile strength and failure strain values, 496 MPa and 0.02, were previously reported for a similar E-glass/polyester composite with a slightly higher fiber volume fraction [4]. The macroscopic damage mechanisms (not shown here) were observed to be matrix cracking, localised warp fiber fracture, weft fiber pull-out and delamination along the middle plies.

The compressive stress–strain curves of brazed small fin and big fin corrugated aluminium cores are shown in Figure 7(b). As observed from Figure 7(b), brazed small fin

corrugated cores exhibit relatively higher collapse stresses than brazed big fin corrugated cores (the collapse stresses were determined by the proportional limit). The reduced fin height and higher relative density of small fin corrugated cores induce relatively higher collapse stresses than in the case of big fin corrugated cores. It is further noted that the difference in the stress values between individual compressions tests are also very similar, proving relatively homogeneous structures of the tested cores. The effect of epoxy bonding on the compression stress–strain curve of big fin corrugated cores is further shown in Figure 7(c); the epoxy bonding of the layers in cores increases both collapse and plateau stresses, but decreases the densification strain slightly. Relatively low-plateau stresses experienced by the brazed corrugated cores result from the annealing of the corrugated aluminium fin sheets, interlayers and face sheets during the brazing process.

The quasi-static compression stress–strain curves of Alulight aluminium foam cores are shown in Figure 7(d). The curves exhibit the characteristics metallic foam deformation behavior, comprising three different deformation regions: (i) linear elastic, (ii) plateau and (iii) rapidly increasing stress (densification) region [1]. In the plateau region, the stress is noted to increase with increasing strain, an effect that is attributed to the density gradient of the foam structure [3].

For comparison, the compression mechanical properties of the corrugated aluminium and aluminium foam cores are tabulated in Table 1. It is noted in the same table that the collapse stress and elastic modulus values of corrugated aluminium foam cores increase with increasing relative density. It is also noted that corrugated aluminium cores experience relatively higher stress oscillations than aluminium foam cores in the plateau region of the compression stress–strain curves. Furthermore, the densification regions

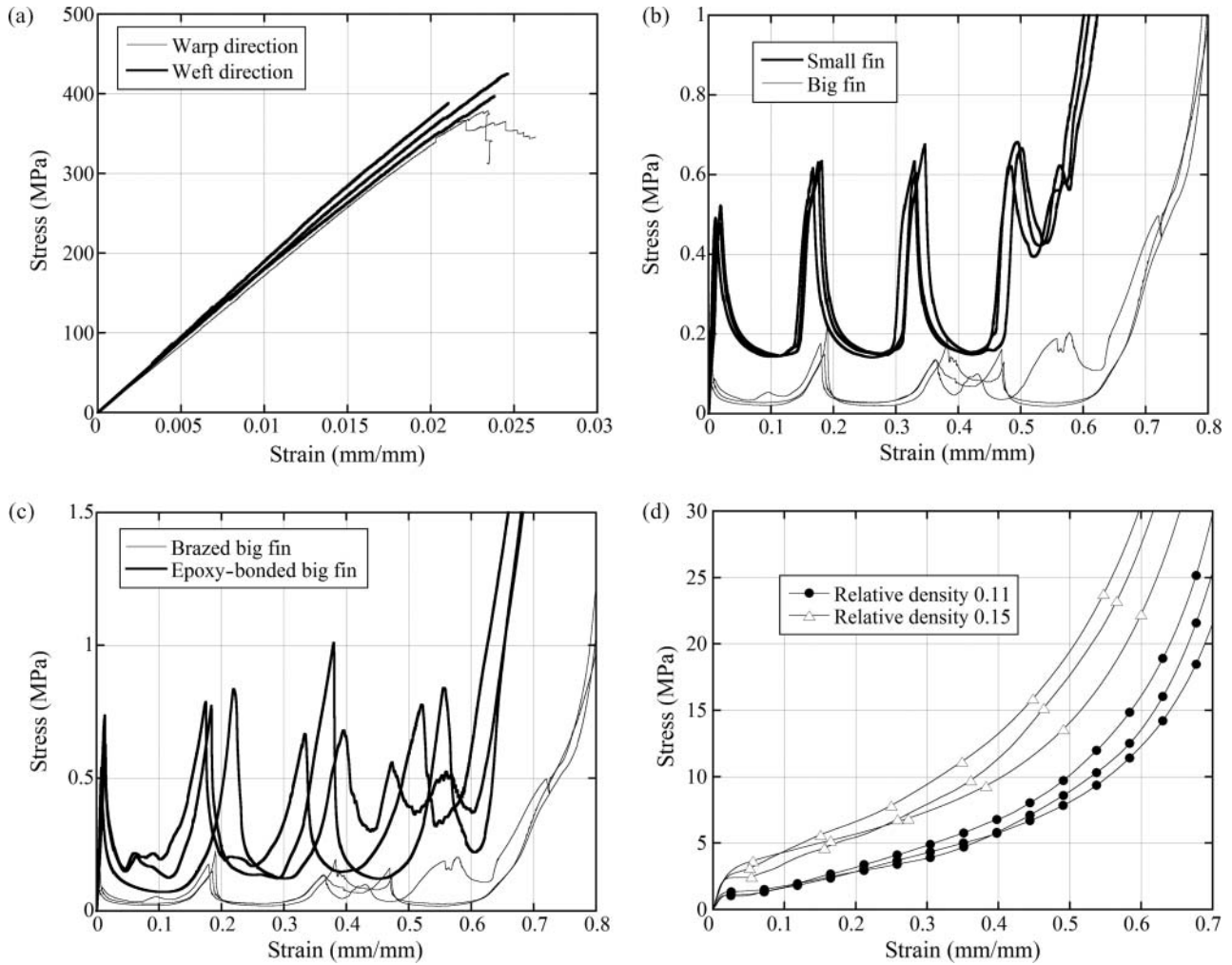

Figure 7. (a) Tensile stress–strain curves of composite plates and compression stress–strain curves of (b) brazen big and small fin corrugated aluminium, (c) epoxy-bonded and brazen big fin corrugated aluminium and (d) Alulight foam cores.

are relatively well defined in the stress–strain curves of corrugated aluminium cores, starting after about 0.6 strain, as compared with those of aluminium foam cores. A noticeable difference in the compression deformation behavior between brazen and epoxy-bonded corrugated cores is observed in the recovered samples after compression testing until about relatively large strains (0.8) in the densification

region. Brazen corrugated core fin layers shown in Figure 8(a) are completely compressed until about densification, without any fracture and detachments of individual sheet layers. A detailed visual inspection of recovered epoxy-bonded tested sample compressed into densification, however, shows brittle fracture of the thin epoxy layer between the sheet layers and accompanying fracture of fin layers,

Table 1. Compressive mechanical property of corrugated aluminium and foam cores.

Material	Density (kg/m <sup>3</sup> )	Collapse stress (MPa)	Modulus (GPa)	Plateau stress (MPa)	Densification strain
Brazen small fin (0.24)	656	0.46	0.055	0.15	0.56
Brazen big fin (0.13)	361	0.18	0.038	0.027	0.65
Epoxy-bonded big fin (0.12)	327	0.6	0.049	0.15	0.62
Aluminium foam (0.15)	405	2.4	0.13	—	0.79
Aluminium foam (0.11)	297	1.11	0.06	—	0.85

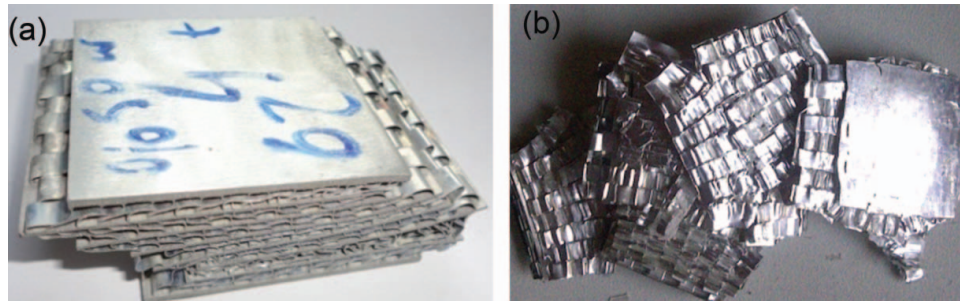

Figure 8. (a) Brazed and (b) epoxy-bonded big fin corrugated aluminium cores recovered after compression testing until about 0.8 strain.

leading to the detachments of the crushed fin and interlayers (Figure 8(b)).

The ballistic limits of E-glass/Polyester composite plates, aluminium foam and corrugated aluminium core panels and sandwich panels as a function of total plate/panel weights are shown together in Figure 9. The ballistic limits of the composite plates vary between 118 m/s and 143 m/s and increase with the increasing thickness-to-weight ratio of the composite plate: ellipse A in Figure 9. Within the investigated composite plate thickness range, nearly a linear increase in the ballistic limit with thickness is further detected (Figure 9). The mean ballistic limit is determined 123 m/s for 2-mm-thick, 133 m/s for 3-mm-thick and 136 mm/s for 5-mm-thick composite plates.

The ballistic limits of the tested corrugated and foam core panels vary around 125 m/s, depicted in Figure 9 (ellipse B). Although, the ballistic limits of the brazed and epoxy-bonded big fin corrugated aluminium core panels are very much similar, brazed corrugated core panels are

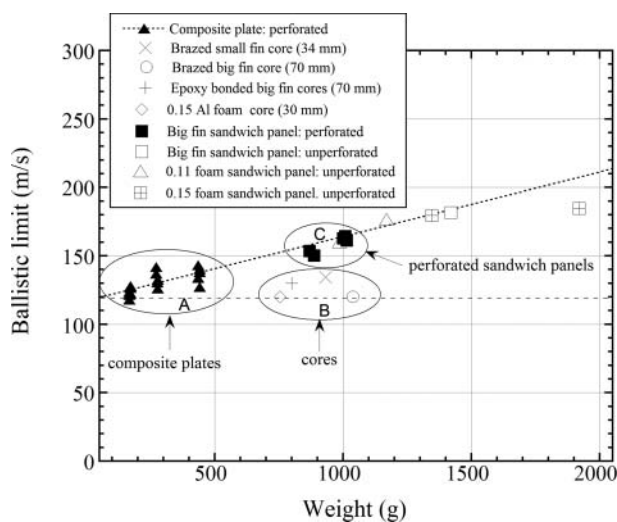

Figure 9. Variation of the ballistic limits composite plates, foam and corrugated aluminium core panels and corrugated aluminium and foam sandwich panels with total weight.

nearly 30% heavier than epoxy-bonded counterparts at the same numbers of fin layers and thicknesses.

Big fin corrugated core sandwich panels with 2- and 3-mm-thick composite face sheets were perforated (ellipse C in Figure 9), but the corrugated core panels with 5-mm-thick composite face sheets exhibited partial penetration at the same projectile velocity. The ballistic limit of epoxy-bonded big fin corrugated panels increases from 130 m/s without face sheets to 152 and 163 m/s with 2- and 3-mm-thick face sheets, respectively. The increase in the ballistic limits of big fin corrugated core sandwich panels with 2- and 3-mm-thick composite face sheets is 17% and 25%, while the weight increase is 9% and 25%, respectively. Comparing the gains in the ballistic limits and weights, the thinner face sheets seems to be more advantageous than thicker face sheets in corrugated core sandwich panels. The tested aluminium foam sandwich panels with 2-, 3- and 5-mm-thick composite face sheets showed no perforation until about 190 m/s impact velocities: the panels were only penetrated.

Figure 10(a)–(f) shows sequentially the front and rear face of projectile impact-tested 2-, 3- and 5-mm-thick composite plates. Although the damage types in the composite plates of different thicknesses are very much similar, the visible damage at the impact zone is seen to increase as the thicknesses, and hence the ballistic limits, of the composite plates increase. It is further noted in Figure 10(a)–(f) that the delamination type damage is intensified at the back surface. The greater rear-face delamination of the glass fiber composite targets was previously observed for relatively large blunt projectile diameters [6]. Similar to previous studies on similar composite structures [4,6,10], the major damage mechanisms involved in the projectile impact testing of the composite plates were delamination and fiber breakage.

Figure 11(a) and (b) shows the cross-section of recovered small and big fin corrugated cores after projectile impact test, respectively. In big fin and small fin corrugated aluminium core panels, fin folding localised at the first couple of layers around the impact zone. It is also seen that the rear face of small fin corrugated core panel is delaminated during projectile impact test (Figure 11(a)), signaling



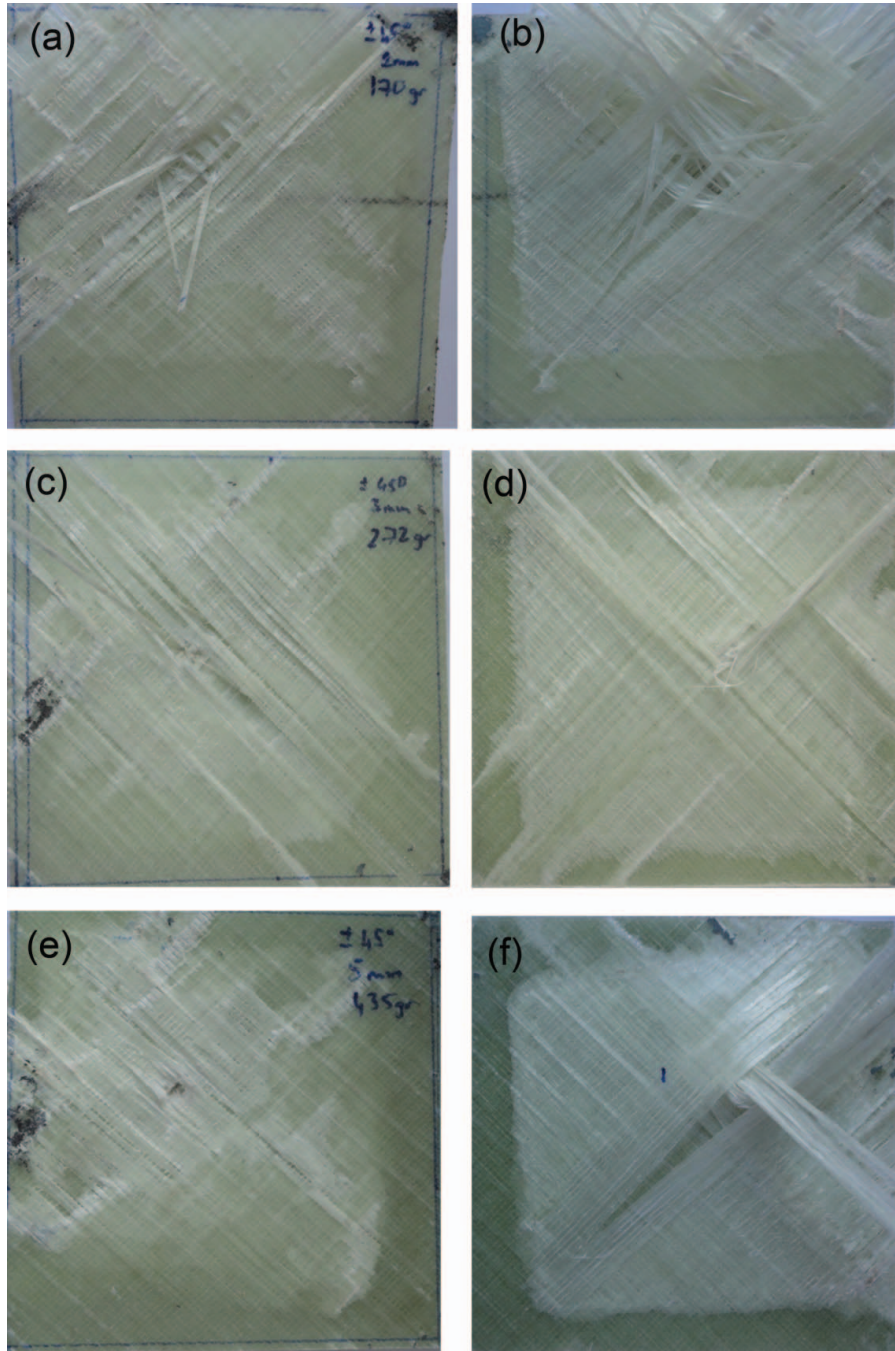

Figure 10. Front and rear faces of composite plates after projectile impact testing: (a) and (b) 2-mm-thick, (c) and (d) 3-mm-thick, and (e) and (f) 5-mm-thick composite plates.

a higher magnitude of the reflected tensile stress waves in small fin corrugated core panels.

Figure 12(a)–(f) shows sequentially the front and rear composite faces of the projectile impact tested big fin corrugated core sandwich panels. The visible damage regions on the front and rear composite face sheets (Figure 12(a)–(f)) are seen to decrease as compared with those of same thick-

ness monolithic composite plates (Figure 10(a)–(f)). For comparison, the cross-sectional views of the tested corrugated aluminium and aluminium foam composite sandwich panels are shown together in Figure 13(a)–(f). It is noted in that as the thickness of the composite face sheet increases, the compression deformation of corrugated aluminium and foam core increases in the impacted side. This

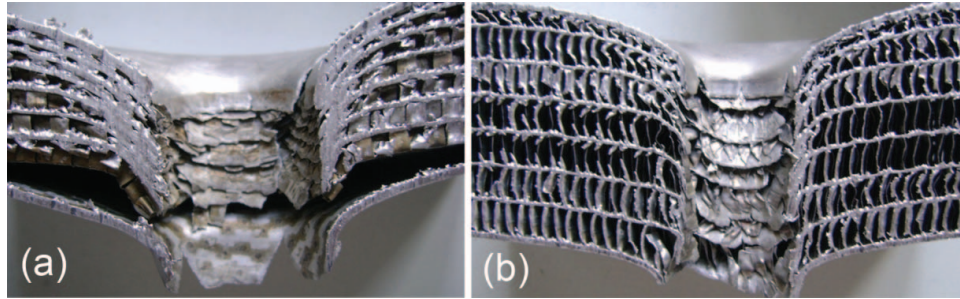

Figure 11. Cross-section of (a) small and (b) big fin corrugated aluminium core panels after projectile impact test.

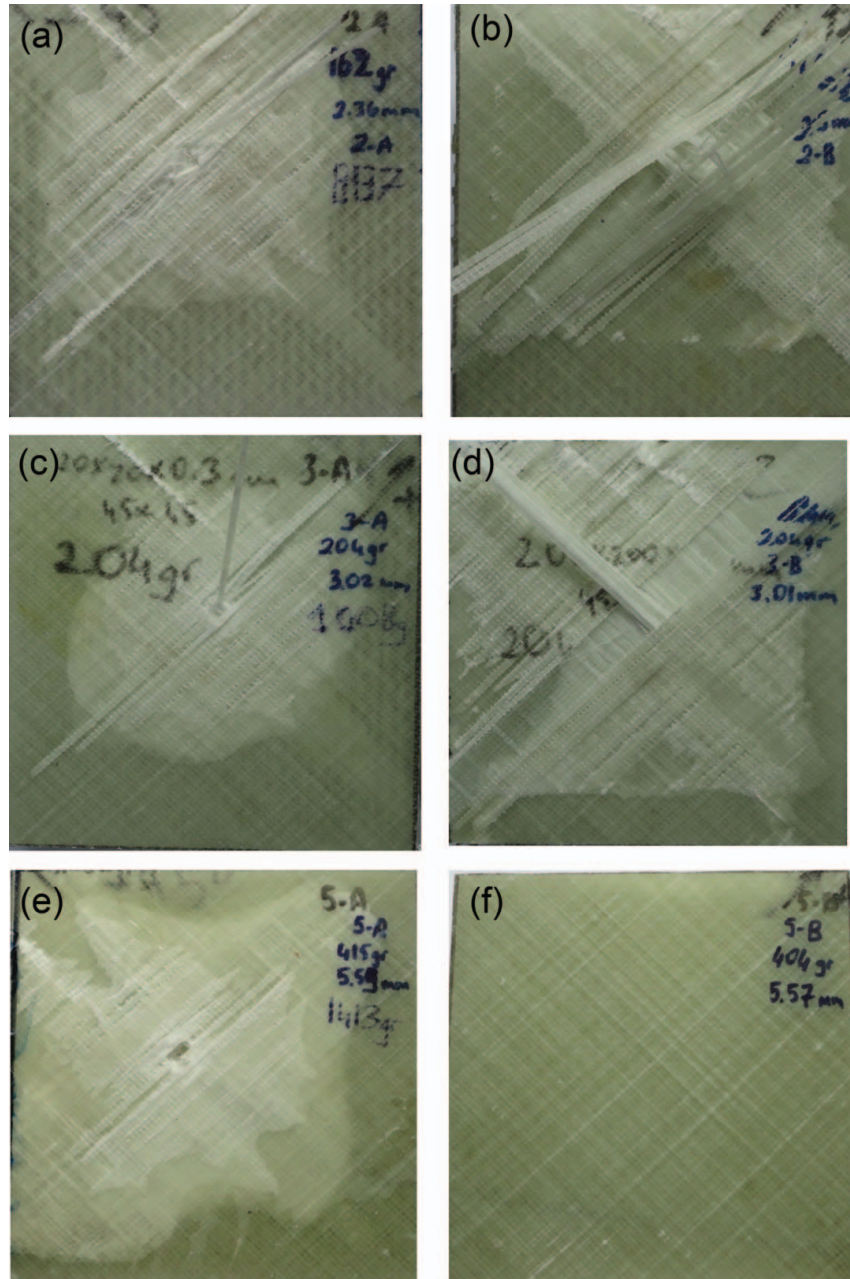

Figure 12. Front and rear faces of the corrugated aluminium composite sandwich panels with (a) and (b) 2-mm-thick, (c) and (d) 3-mm-thick, and (e) and (f) 5-mm-thick composite face sheet panels.

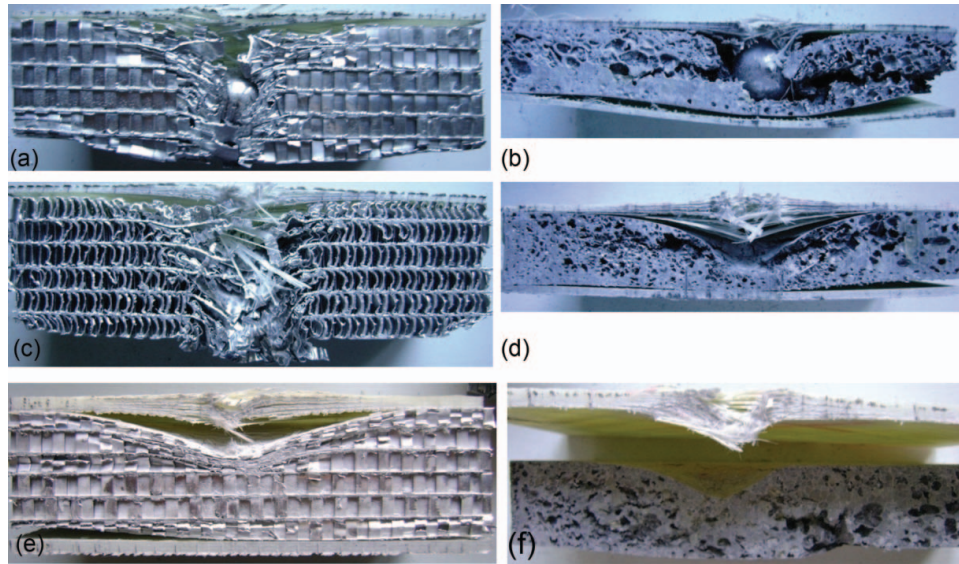

Figure 13. Cross-sectional views of corrugated aluminium core and aluminium foam core sandwich panels with (a) and (b) 2-mm-thick, (c) and (d) 3-mm-thick, and (e) and (f) 5-mm-thick composite face sheets.

is clearly observable from Figure 13(e) and (f): the projectile locally indents and compresses completely the front side of the corrugated aluminium and foam core in the sandwich panel with 5-mm-thick composite face sheets. Previous investigations showed that as the thickness of the face sheet increased, a compressive type of failure of the aluminium foam core appeared [15]. It was presumed that the increased flexural stiffness of the composites with increasing thickness increased the force required to perforate the composite laminate, resulting in greater crushing of the aluminium corrugated and foam core.

A close analysis of the back impact surfaces of the cores in Figure 14(a) and (b) reveals a larger damage zone formation in the aluminium foam core sandwich panels.

At the rear face of the aluminium foam core, the cracks emanating from the central part and propagating to edge of the core are clearly seen. The foam core distributes the incoming projectile momentum to a relatively larger area, leading to reduced pressure on the backing composite plate. The cracking and forming a plug of the foam core at the back surface is further attributed to the brittle nature of the foam core. Almost similar observations are seen in foam core sandwich panels with different thicknesses of composite face sheets.

The results of preliminary investigation on corrugated aluminium and aluminium foam core composite sandwich panels reveal that the aluminium foam core provides higher resistance than corrugated aluminium cores in the sandwich

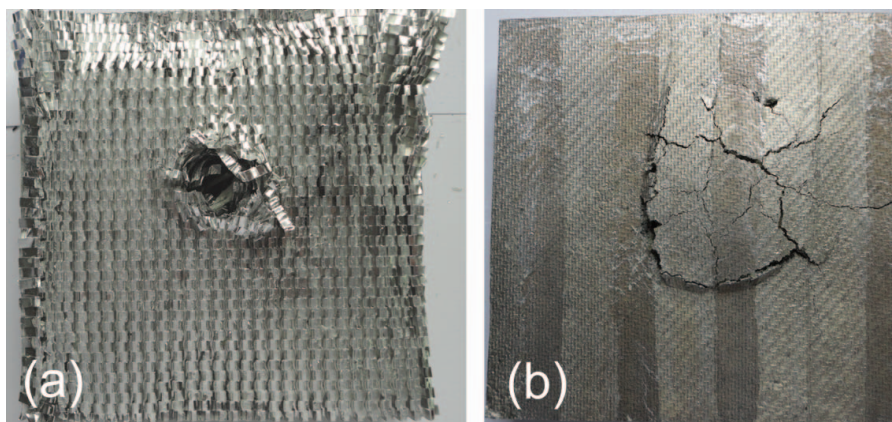

Figure 14. Back surface of a 3-mm-thick face sheet sandwich panel after projectile impact testing: (a) big fin corrugated core sandwich panel and (b) 0.15 relative density aluminium foam core sandwich panel (after removing rear composite face sheets).

panels against projectile impact at similar weights. This is partly due to the higher strength of foam aluminium alloy AlSi10 than aluminium alloy 1050 used to construct corrugated aluminium, leading to increased energy absorption. A further study would be the comparison of corrugated and foam cores with similar collapse stresses. Besides, the thickness of sheet layer and the geometry of corrugated fin layer are expected to affect the impact response of corrugated structures and a parametric optimisation schedule is certainly needed.

## 5. Conclusions

E-glass/polyester composite and corrugated aluminium and aluminium foam core sandwich panels were projectile impact tested between 127 m/s and 190 m/s impact velocities using a hardened steel sphere projectile. Quasi-static compression tests showed that corrugated aluminium cores exhibited lower-plateau stresses and higher oscillations in the plateau region than aluminium foam cores. The tested composite plates in 2-, 3- and 5-mm thickness and epoxy-bonded big fin corrugated sandwiches panels, except 5-mm-thick composite sandwich panels, were perforated in projectile impact test. The tested aluminium foam sandwich panels showed partial penetration. A comparison based on the ballistic limits as a function of total weight showed that the insertion of composite face sheets increased the ballistic limits of corrugated aluminium and aluminium foam cores without significantly increasing the weight. The aluminium foam core provided higher resistance than corrugated aluminium cores in the sandwich panels against projectile impact at similar weights. This was attributed to the relatively higher strength of the foams investigated and the ability of distributing the incident impulse to a relatively large area in the backing composite plate.

## Acknowledgements

The authors would like to thank Cumhuriyet Akar for providing corrugated aluminium core samples.

## References

- M. Ashby and R. Medalist, *The mechanical properties of cellular solids*, Metall. Mater. Trans. A 14 (1983), pp. 1755–1769.
- J. Banhart, *Manufacture, characterisation and application of cellular metals and metal foams*, Prog. Mater. Sci. 46 (2001), pp. 559–632.
- J.T. Beals and M.S. Thompson, *Density gradient effects on aluminium foam compression behaviour*, J. Mater. Sci. 32 (Jul 1997), pp. 3595–3600.
- E.P. Gellert, S.J. Cimpoeu, and R.L. Woodward, *A study of the effect of target thickness on the ballistic perforation of glass-fibre-reinforced plastic composites*, Int. J. Impact. Eng. 24 (2000), pp. 445–456.
- V.S. Deshpande and N.A. Fleck, *High strain rate compressive behaviour of aluminium alloy foams*, Int. J. Impact. Eng. 24 (2000), pp. 277–298.
- E.P. Gellert, S.J. Cimpoeu, and R.L. Woodward, *A study of the effect of target thickness on the ballistic perforation of glass-fibre-reinforced plastic composites*, Int. J. Impact. Eng. 24 (2000), pp. 445–456.
- L.J. Gibson, *Mechanical behavior of metallic foams*, Annu. Rev. Mater. Sci. 30 (2000), pp. 191–227.
- A.G. Hanssen, Y. Girard, L. Olovsson, T. Berstad, and M. Langseth, *A numerical model for bird strike of aluminium foam-based sandwich panels*, Int. J. Impact. Eng. 32 (2006), pp. 1127–1144.
- W. Hou, F. Zhu, G. Lu, and D.-N. Fang, *Ballistic impact experiments of metallic sandwich panels with aluminium foam core*, Int. J. Impact. Eng. 37 (2010), pp. 1045–1055.
- S.T. Jenó, H.S. Jing, and C. Chung, *Predicting the ballistic limit for plain woven glass epoxy composite laminate*, Int. J. Impact. Eng. 15 (1994), pp. 451–464.
- C.C. Liang, M.F. Yang, and P.W. Wu, *Optimum design of metallic corrugated core sandwich panels subjected to blast loads*, Ocean Eng. 28 (2001), pp. 825–861.
- G.J. McShane, D.D. Radford, V.S. Deshpande, and N.A. Fleck, *The response of clamped sandwich plates with lattice cores subjected to shock loading*, Eur. J. Mech. A-Solid 25 (2006), pp. 215–229.
- D.D. Radford, N.A. Fleck, and V.S. Deshpande, *The response of clamped sandwich beams subjected to shock loading*, Int. J. Impact. Eng. 32 (2006), pp. 968–987.
- H.J. Rathbun, D.D. Radford, Z. Xue, M.Y. He, J. Yang, V. Deshpande, N.A. Fleck, J.W. Hutchinson, F.W. Zok, and A.G. Evans, *Performance of metallic honeycomb-core sandwich beams under shock loading*, Int. J. Solids Struct. 43 (2006), pp. 1746–1763.
- G. Reyes-Villanueva and W.J. Cantwell, *The high velocity impact response of composite and FML-reinforced sandwich structures*, Compos. Sci. Technol. 64 (2004), pp. 35–54.
- V. Rubino, V.S. Deshpande, and N.A. Fleck, *The dynamic response of end-clamped sandwich beams with a Y-frame or corrugated core*, Int. J. Impact. Eng. 35 (2008), pp. 829–844.
- V. Rubino, V.S. Deshpande, and N.A. Fleck, *The dynamic response of clamped rectangular Y-frame and corrugated core sandwich plates*, Eur. J. Mech. A-Solid 28 (2009), pp. 14–24.
- ASTM International, *Tests Methods for Tensile Properties of Polymer Matrix Composite Materials*, ASTM International, West Conshohocken, PA, 2004.
- M.T. Tilbrook, D.D. Radford, V.S. Deshpande, and N.A. Fleck, *Dynamic crushing of sandwich panels with prismatic lattice cores*, Int. J. Solids Struct. 44 (2007), pp. 6101–6123.
- A.K. Toksoy and M. Guden, *The optimisation of the energy absorption of partially Al foam-filled commercial 1050H14 and 6061T4 Al crash boxes*, Int. J. Crashworthiness 16 (2011), pp. 97–109.