



Investigation of humidity sensing properties of ZnS nanowires synthesized by vapor liquid solid (VLS) technique

N. Üzar^{a,*}, S. Okur^b, M.Ç. Arıkan^a

^a Istanbul University, Science Faculty, Physics Department, Vezneciler, 34134 Istanbul, Turkey

^b Izmir Institute of Technology, Faculty of Science, Department of Physics, Gülbahçe Koyu Kampüsü, Urla, Izmir 35430, Turkey

ARTICLE INFO

Article history:

Received 12 July 2010

Received in revised form 1 October 2010

Accepted 13 October 2010

Available online 21 October 2010

Keywords:

ZnS nanowires

XRD

QCM

Humidity sensor

ABSTRACT

Zinc sulfide (ZnS) nanostructures were synthesized by vapor–liquid–solid (VLS) method which is based on thermal evaporation. The morphology, chemical composition and crystal structure of ZnS nanostructures were characterized by scanning electron microscopy (SEM), energy dispersive spectroscopy (EDS) and X-ray diffraction (XRD) analyses. The results of these studies revealed that wurtzite ZnS nanowires with diameters in range of 50–400 nm are obtained. In order to investigate the humidity sensing capability, quartz crystal microbalance (QCM) and electrical resistance measurement techniques were carried out at different relative humidity (RH) conditions between 33% and 100% RH at room temperature. QCM results show that the oscillating frequency of ZnS nanowires loaded on QCM crystal decreases in range of 33–84% RH, but increases at 90% and 100% RH. The sensitivity of ZnS nanowires-based sensor ($R_{\text{air}}/R_{\text{RH}}$) increases over 1000 times from 33% to 100% RH. These experimental results show that ZnS nanowires have a great potential for humidity sensing applications at room temperature.

© 2010 Elsevier B.V. All rights reserved.

1. Introduction

Semiconducting materials have been proposed as sensing elements for the detection of gases, vapors and humidity due to their superior features such as very high surface to volume ratio, their size related quantum confinement properties, lower cost and ease in fabrication. These effects lead to physical and chemical behaviors that are superior from the bulk counterparts [1]. The physical and the chemical properties of materials can be tuned and manipulated with changing the dimension of materials. These all reasons increase sensitivity and performance of materials as sensor against the humidity and gases [2,3]. Especially, sensing of humidity is an important quantity to control in many manufacturing environments such as food, automotive, electronics and agriculture industries. Therefore, reliable, cheap, sensitive, low operation temperature and small-sized humidity sensors are indispensable for daily life.

Both QCM technique [4–6] and electrical resistance measurement [7] have been widely used for determining the sensing properties of materials before a sensor device design during development stages. QCM technique makes it possible to detect very small mass changes as well as viscoelastic properties during the adhesion of QCM crystal. The sensor of the QCM consists of a thin quartz crystal plate with Au evaporated electrodes on two sides of

it. Two Au electrodes establish an alternating electric field across the quartz crystal, causing vibrational motion of the crystal at its resonant frequency. The most general definition of QCM working process can be given with Sauerbrey equation [8]. The resonant frequency sensitive to mass change of the quartz crystal i.e. a change of resonance frequency (Δf) is proportional to the amount of adsorbed mass (Δm). Sauerbrey equation which is given at below is valid only for thin, uniform and rigid adlayer.

$$\Delta f = -\frac{2f_0^2}{A\sqrt{\mu\rho}}\Delta m \quad (1)$$

where f_0 is the resonant frequency of the fundamental mode of the QCM crystal; Δf is the frequency change of the quartz crystal; A is the area of the gold disk coated onto the crystal; ρ is the density of the crystal; and μ is the shear modulus of quartz.

Electrical resistance measurement based on charge exchange which occurs between adsorbed species from the moisture molecules and the material surface. Nanostructures have high surface to volume ratio (large specific area) to produce a higher charge exchange rate. Especially nanowires have large specific area due to their porous structure [9].

ZnS is an II–VI semiconductor compound with wide direct band gap energy. The attendant structural reordering in different solvent environments (water, methanol. . .) suggested a possible use of ZnS nanowires as environmental sensors due to surface chemical properties of ZnS.

In this work, we synthesized ZnS nanowires using VLS method and the morphology, the chemical compositions and the crystal

* Corresponding author. Tel.: +90 535 427 12 71.

E-mail addresses: neslihanuzar@gmail.com, neslihanuzar@yahoo.com (N. Üzar).

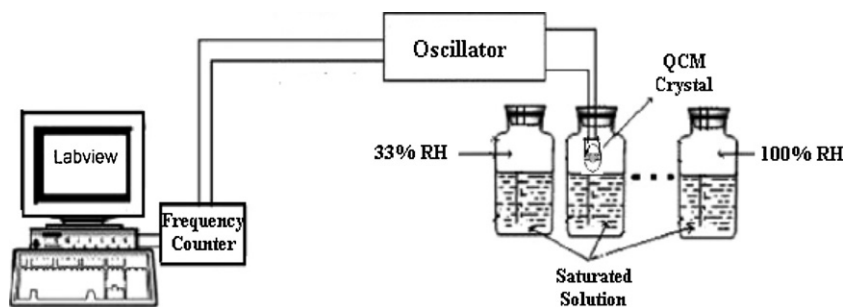

Fig. 1. The experimental QCM setup to measure humidity sensing properties of ZnS nanowires under fixed point humidity between 33% RH and 100% RH above a saturated salt solution inside a closed glass vessel.

structure of ZnS nanowires were analyzed by SEM, EDS and XRD analyses, respectively. Humidity sensing capabilities of the ZnS nanowires were investigated by QCM and electrical resistance measurement with increasing relative humidity (RH) from 33% to 100%.

2. Experimental

2.1. Synthesis of ZnS nanowires

ZnS nanowires synthesized using VLS method. The synthesis of nanowires is based on thermal evaporation of ZnS powders under controlled conditions and transfer of ZnS vapor to Au film (about 5 nm) coated Si substrate which is lower temperature region by using an inert gas as a carrier. Here Au film was used as catalyst. The synthesis of ZnS nanowires was carried out in a quartz tube placed inside a high temperature horizontal tube furnace. Pure ZnS powders were put in a quartz boat located at the center of the tube. The substrate was placed at 700 °C temperature region in the tube. The tube was evacuated with a vacuum pump for 3 h prior to heating to eliminate any oxygen in the tube. Then the furnace was rapidly heated to 1100 °C and kept at this temperature for 1 h. ZnS vapor was carried on the substrate under a constant flow of Ar gas (500 sccm). After the system being cooled to room temperature a white, sponge-like layer was observed on the surface of Au coated Si substrate.

2.2. Structural characterization of ZnS nanowires

The surface morphology and chemical composition of ZnS nanowires were investigated using SEM and EDS, respectively. SEM equipped with EDS and same sample was used to take SEM images and EDS spectrum. XRD analysis (with Cu K α 1 line) was carried out to determine of crystal structure of ZnS nanowires.

2.3. Humidity sensing capabilities of ZnS nanowires using QCM technique under varying relative humidity

A QCM with the model of CHI400A Series from CH Instruments (Austin, USA) has been used to measure the change in the resonance frequency of quartz crystals between gold electrodes via both serial and USB interface connected to a computer. The working oscillation frequencies of QCM crystal are between 7.995 MHz and 7.950 MHz. The density (ρ) of the crystal is 2.684 g/cm³, and the shear modulus (μ) of quartz is 2.947×10^{11} g/cm s². A net change of 1 Hz corresponds to 1.34 ng of materials adsorbed or desorbed onto the crystal surface of an area of 0.196 cm².

In order to monitor humidity sensing properties, the quartz crystals were cleaned first by placing into acetone and ultrasonically cleaned. Then rinsed by de-ionize water and dried with Ar gas. ZnS nanowires are ultrasonically dispersed in ethanol and solution was applied on the surface of quartz crystal by drop-

casting technique. The solution was dried at room temperature in air environment until ethanol was totally evaporated. Then the ZnS nanowires coated quartz crystal was mounted in closed glass vessels which were obtained saturated aqueous solution of 33, 43, 55, 75, 84, 90 and 100% RH. Humidity sensing properties of ZnS were investigated at an ambient temperature of 22 °C using hybrid system of QCM electrodes and a commercial humidity sensor which was used to measure the humidity of environment. Both signals coming from QCM and commercial humidity sensor were simultaneously measured during the adsorption and desorption process. To measure reproducibility and stability of ZnS nanowires, sensor was exposed to varying relative humidity for repeated cycles alternately. Experimental set up is shown in Fig. 1.

A EI-1050 selectable digital relative humidity and temperature probe with a response time of 4 s and a resolution of 0.03% RH was used with a USB controlled U12 ADC system combined with a single chip sensor module (SHT11) manufactured by Sensirion (Stäfa, Switzerland).

2.4. Electrical measurement of ZnS nanowires versus different relative humidity

The other sensing mechanism for humidity is resistance measurements of ZnS nanowires versus different relative humidity. QCM and electrical measurements were taken same time and environment. The ZnS nanowires–ethanol solution was dropped between the thermally evaporated widths of 1300 μ m gold electrodes with 25 μ m separation on a glass substrate for electrical resistance measurements. Therefore, ZnS nanowires bridged the two neighboring gold electrodes. Two copper (Cu) lead wires were connected to electrodes by silver paint. A high current–voltage precision Keithley 2420 multimeter was used to measure the variation of resistance of ZnS nanowires. Custom Labview-based software was used to autonomously control the experimental setup and take measurement of the ZnS nanowire based sensor. To measure reproducibility and stability of ZnS nanowires, sensor was exposed to humidity for repeated cycles alternately. Simple schematic diagram of the electrical resistance measurement system is shown in Fig. 2.

3. Results and discussion

3.1. Structural characterization of ZnS nanowires

Fig. 3 presents SEM images of the ZnS nanowires on thickness of 5 nm Au coated Si substrate placed at 700 °C temperature zone of the horizontal tube. SEM observation demonstrates that the lengths of the ZnS nanowires can reach to several tens of micrometers and the diameters of the nanowires change from about 50 nm to 400 nm.

EDS spectrum of the ZnS nanowires is given in Fig. 4. EDS spectrum shows that synthesized product consists of only Zn and S

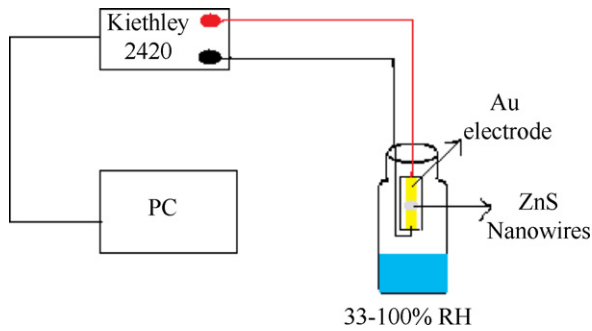

Fig. 2. The schematic diagram of resistance measurement of ZnS nanowires under varying relative humidity from 33% to 100%.

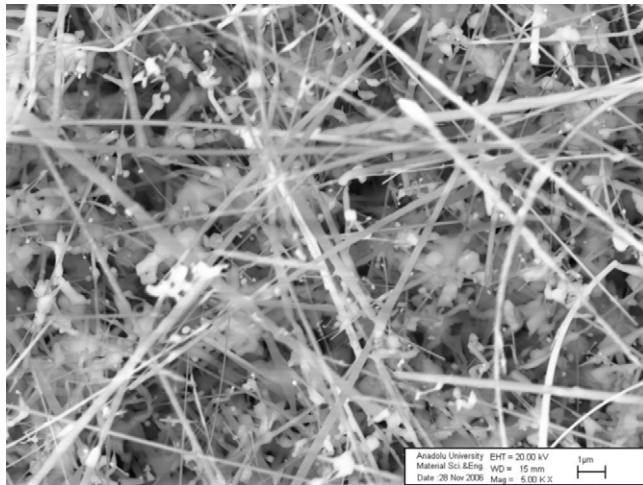

Fig. 3. SEM images of the ZnS nanowires deposited on Au coated Si substrates placed at 700 °C.

elements. The atomic ratio of Zn:S was found as 49.91%:50.09%. This elementary analysis shows that the synthesized product is stoichiometric ZnS compound.

The XRD spectrum in Fig. 5 indicates that the nanostructure could be formed of wurtzite-2H structured ZnS with lattice parameters of $a = 3.82098$ nm and $c = 6.2573$ nm, which matches well with the JCPDS card (36-1450). Au peaks in XRD spectrum are event of VLS mechanism.

3.2. QCM results of ZnS nanowires under varying relative humidity

The frequency shift is measured as a function of relative humidity within time interval 100 s. Fig. 6 shows the frequency shift of loaded (open blue square) and unloaded (open black square) QCM

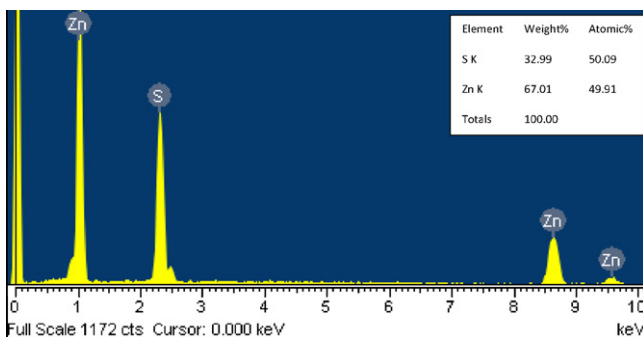

Fig. 4. EDS spectrum of ZnS nanowires.

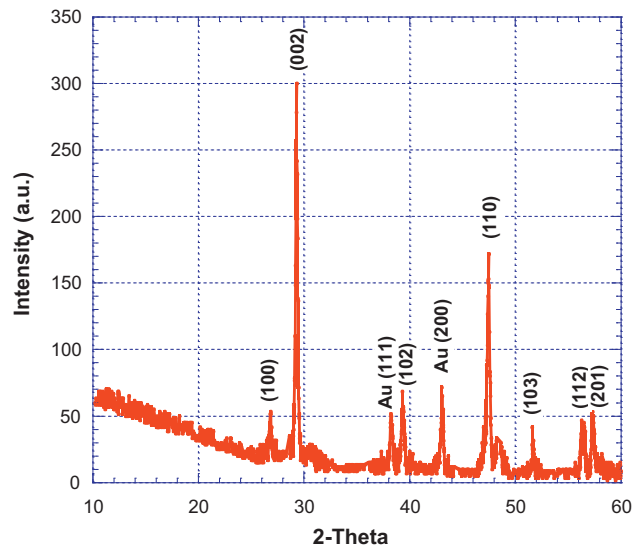

Fig. 5. XRD spectrum of ZnS nanowires.

with drop-casted ZnS nanowires comparing with relative humidity (RH) values of a commercial sensor (open red square) for 3 humidity adsorption–desorption cycles between 55% and 75% RH.

During the adsorption process the oscillating frequency of QCM decreases with increasing RH, i.e. the frequency shift of ZnS nanowires versus humidity molecules results in a negative frequency shift while there is no change in that of the empty QCM crystal during adsorption process. On the other hand, during the desorption process the RH decreases suddenly to the 55% and the frequency shift of ZnS nanowires increases due to decreasing mass on QCM surface. The magnitude of change in the oscillating frequency is a little large in the first adsorption–desorption cycle compared to the latter repeated cycles due to slower desorption rate.

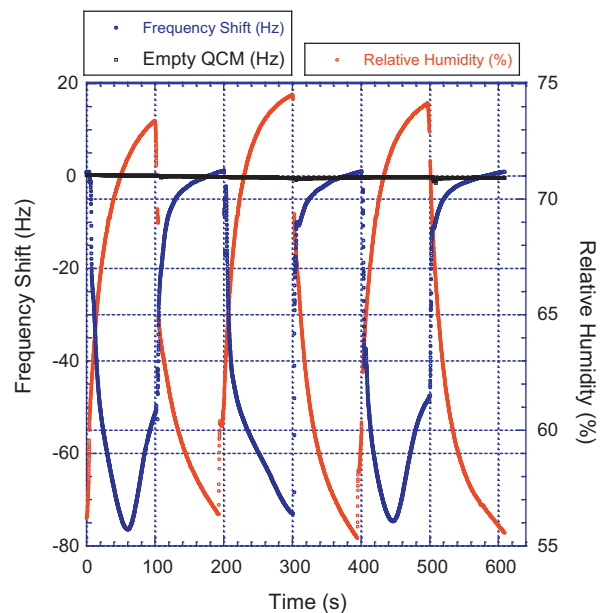

Fig. 6. The frequency shift of ZnS nanowires covered QCM (open blue square) comparing with relative humidity values of a commercial sensor (open red square) for 3 humidity adsorption–desorption cycles between 55% and 75% RH. Also black line shows response of empty QCM crystal against the same relative humidity values. (For interpretation of the references to color in this figure legend, the reader is referred to the web version of the article.)

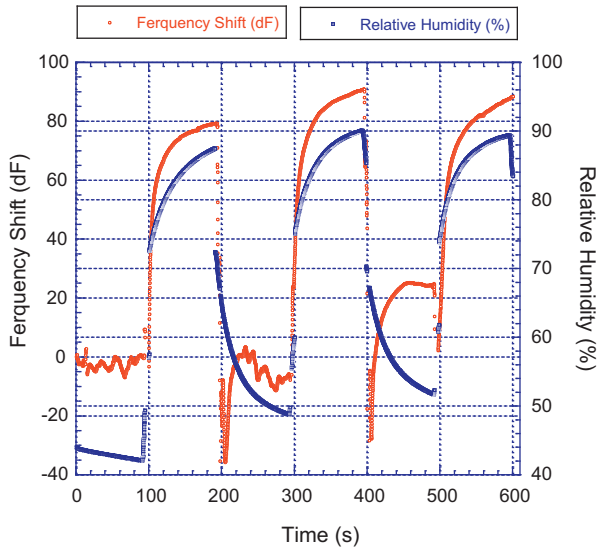

Fig. 7. The frequency shift of ZnS nanowires covered QCM (open red squares) comparing with relative humidity values of a commercial sensor (open blue squares) for 3 moisture adsorption–desorption cycles between 45% and 90% RH. (For interpretation of the references to color in this figure legend, the reader is referred to the web version of the article.)

Further studies of response and recovery time were carried out for dynamic testing procedures, which provided more information on the most important parameters for a sensing device. The response time, defined as the time needed to reach 90% of the final signal for a given RH and recovery time defined as the time taken for the signal to come within 10% of the initial value after removal of RH % [10]. The response and recovery time of ZnS nanowires based sensor were found as about 14 s and 18 s, respectively.

Fig. 7 shows that change of the frequency shift of ZnS nanowires coated quartz crystal is varied cyclically as a function of time at two relative humidity points: about 45% RH and 90% RH. A positive frequency shift is observed at 90% RH. But the ZnS coated QCM crystal was exposed the 45% RH at room temperature, QCM crystal recovers back to nearly its initial resonance frequency value due to desorption of moisture molecules from surface on the sensor.

Variations in frequency shift of ZnS nanowires coated QCM crystal with different relative humidity is shown in Fig. 8. As %RH increase, the frequency shift of QCM crystal decreases slowly up to 55% and then decreases more sharply at 75% and 84%. At two relative humidity points which are 90% and 100% RH the frequency shift of crystal increases. This result is very important. Because ZnS nanowires coated QCM crystal show that negative frequency shift behavior up the 84% RH. This behavior correspond well-known relation described by Sauerbrey equation which was given with Eq. (1) and the mass of adsorption moisture molecules on the ZnS nanowires increases with decreasing the frequency shift of ZnS nanowires loaded QCM crystal. ZnS nanowires based sensor shows positive frequency shift behavior at 90% and 100% RH. This experimental study was repeated three times under same condition. The experimental results showed similar results for each experiment. The frequency response of QCM crystal starts to change at 90% RH, i.e. the behavior of QCM crystal versus relative humidity deviated from Sauerbrey equation. This situation can be explained a number of ways. One explanation is for the non-rigid small added mass much less than the mass of the crystal. If the mass is rigidly attached to the quartz crystal surface so that it vibrates rigidly with it too. An oscillating solid deposit can have the same velocity as the quartz crystal surface throughout. Sauerbrey equation is valid for this condition. While the frequency shift decreases, Sauerbrey equation

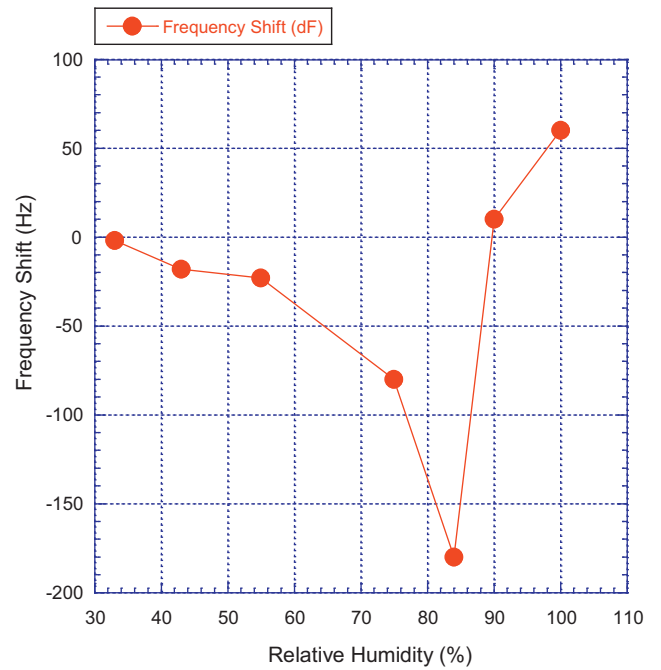

Fig. 8. The frequency shift of ZnS nanowires covered QCM against the varying humidity relative from 33% to 100%.

does not give any information about physical properties of the deposited solid film onto quartz crystal. But the large mass which was adsorbed onto ZnS nanowires coated quartz crystal can change the elastic properties of the ZnS nanowires and can cause to positive frequency shift [11,12]. The Sauerbrey equation is not valid for this condition and a different equation can be derived for considering the physical properties of the deposited solid film onto quartz. We know that the shift of resonance frequency of the QCM crystal arises from perturbation by the deposited mass onto the crystal surface or elastic properties of the deposited material onto the QCM crystal. Hunt et al. [12,13] derived the equation using time-dependent perturbation theory for explaining the positive frequency shift,

$$t \frac{\partial \Delta \omega}{\partial t} + \Delta \omega = \frac{\omega_u h_f}{\pi \sqrt{\rho_q \mu_q}} x \left[-\omega_u \left(\Delta \rho - \frac{\Delta \mu}{V_s^2} \right) + j \left(\frac{\partial \Delta \rho}{\partial t} - \frac{1}{V_s^2} \frac{\partial \Delta \mu}{\partial t} \right) \right] \quad (2)$$

where ρ is the density of the film; μ_q is the shear stiffness of the quartz, μ is the stiffness of the film; h_f is the thickness of the deposited film, ρ_q is the mass density of quartz, V_s is the acoustic velocity across the deposited film thickness, Δ is the difference between perturbed and unperturbed quantities, and subscript u is used for the unperturbed quantities. Kinetic changes can be ignored due to $\Delta \rho$, $\Delta \mu$ and $\Delta \omega$ do not change with time. That is why; Eq. (2) can be given at below,

$$\Delta f = - \frac{2f_u^2 h_f}{\sqrt{\rho_q \mu_q}} \left(\Delta \rho - \frac{\Delta \mu}{V_s^2} \right) \quad (3)$$

The mass value loaded on the film can be expressed as $\Delta m = \Delta \rho A h_f$ (A is sensing area), Eq. (3) is complying with Sauerbrey equation including static changes in the mechanical stiffness of the deposited film. Eq. (3) exhibits that mass attaching onto the sensor will cause to decrease at frequency shift but mechanical stiffness will increase the frequency shift. So that in this study, mechanical stiffness can dominant process and ZnS film which consists of nanowires can transform from a rigid film to a soft film at 90% RH and above RH due to the larger amount of moisture molecules can

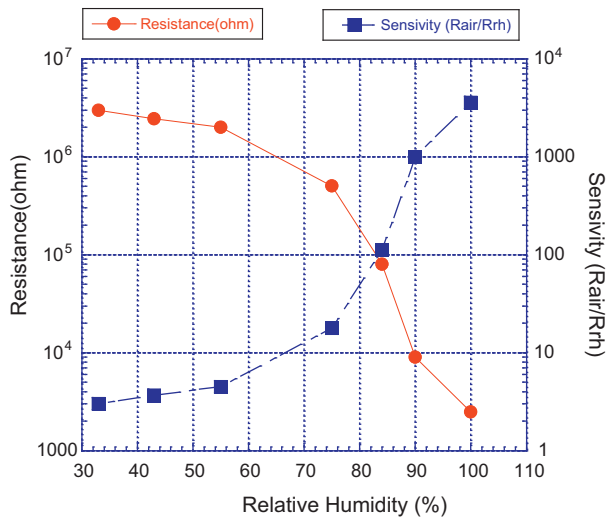

Fig. 9. The variation in resistance and sensitivity of ZnS nanowires depending on varying relative humidity.

adsorb the surface of ZnS film [14]. So the large mass can increase on the surface of the quartz crystal.

The other explanation, besides the initial decrease of frequency, a subsequent increase can relate with the liquefaction of the adsorption product [15]. Evaporated humidity molecules adsorb on the surface of the ZnS film. The pressure in the closed glass vessel increases with increasing % RH. Adsorbed humidity molecules as gas state on the surface of ZnS film can start liquefaction due to the high pressure.

3.3. Electrical measurements results of ZnS nanowires under varying relative humidity

Resistance–time ($R-t$) measurement depending on varying RH conditions was carried out ZnS nanowires as electrical measurements. Fig. 9 shows the variations of resistance and sensitivity of ZnS nanowires depending on % RH. While decreasing the resistance, sensitivity increases with increasing %RH. A meaningful variation in resistance of ZnS nanowires was not observed at low humidity relative values. When %RH increases, a very small decreasing change was observed in the resistance value up to 55%RH. After this value, the resistance of ZnS nanowires decreases rapidly with exhibiting nearly linear behavior. Decreasing of resistance is an expected situation. The theory of the humidity operation mechanisms can be based on that molecules of the humidity interact with semiconductor surfaces to influence surface conductivity and surface potential due to physical and chemical adsorption of moisture molecules on the ZnS nanowires surface [16]. Strong interaction can accrue between the water and surface of ZnS nanowires. The polar water molecules orient to permit hydrogen (H) and oxygen (O) bonding to the terminating S^{2-} and Zn^{2+} ions. Some FTIR measurements results show that S–H and Zn–O bonding were observed on the surface of ZnS nanowires as a result of interaction between the water and ZnS [17]. That is why charge exchange occurs in a thin layer below humidity–sensor interface. Therefore, the resistance of ZnS nanowires decreases with increasing the amount of charge depending on increasing % RH.

The sensitivity of the ZnS nanowire-based sensors in this work is defined as R_{air}/R_{RH} . The sensitivity increases about 1000 times from 33% to 100% RH depending on decreasing the resistance of ZnS nanowires as illustrated in Fig. 9. As the ZnS nanowires have a porous surface. It will provide more surfaces for adsorption, resulting in enhanced sensitivity.

Nanostructures have a great potential for humidity sensing applications at room temperature due to very high aspect ratio. Furthermore ZnS is very appropriate material for humidity sensor due to physical and chemical properties of ZnS material, i.e. ZnS has response versus water molecules. That's why; in the future we can study on ZnS nanodots and doped-ZnS nanostructures. Nanodots have the highest volume–surface ratio and the doped materials can react with water molecules easily. The sensitivity of ZnS nanowires based sensor can be less than the that of ZnS nanodots and doped - ZnS nanostructures. Owing to whole these reasons; the sensitivity of ZnS nanostructures based sensor can increase.

In the future work, we can synthesize the ZnS nanodots and investigate humidity, gas and optical sensing properties of obtained ZnS nanodots via electrical resistance measurement. ZnS is a semiconductor material and the resistance will decrease depending on sensing condition.

4. Conclusion

ZnS nanowires were synthesized successfully by VLS method with their diameters range from 120 nm to 160 nm. The results of QCM measurement demonstrated that ZnS nanowires loaded quartz crystal transforms from the negative frequency shift to the positive frequency shift with increasing amount of relative humidity (after 90%RH). The sensitivity of ZnS nanowires against humidity increases from 33%RH to 100%RH depending on decreasing the resistance of ZnS nanowires. The resistance decreases about 1000 times from 33%RH to 100%RH. The response and recovery time are very fast. All results show that ZnS nanowires can be used as humidity sensor, especially resistive humidity sensor.

Acknowledgements

This research were partially supported by DPT (State Planning Organization of Turkey) under project number DPT2003K120390, by Tubitak (Turkish Scientific Association) under project number TBAG 109T240 and by the Research Fund of the Istanbul University in Turkey with Project number T-676.

References

- [1] X.F. Duan, C.M. Lieber, General synthesis of compound semiconductor nanowires, *Adv. Mater.* 12 (2000) 298–302.
- [2] L. Sun, C. Liu, C. Liao, C. Yan, ZnS nanoparticles doped with Cu(I) by controlling coordination and precipitation in aqueous solution, *J. Mater. Chem.* 9 (1999) 1655–1657.
- [3] S. Kishimoto, A. Kato, A. Natio, Y. Sakamoto, S. Iida, Attempts of homo p–n junction formation in ZnS by impurity co-doping with vapor phase epitaxy, *Phys. Status Solidi B* 229 (2002) 391.
- [4] J. Hartmann, J. Auge, R. Lucklum, S. Rösler, P. Hauptmann, B. Adler, E. Dalcanele, Supramolecular interactions on mass sensitive sensors in gas phases and liquids, *Sens. Actuators B* 34 (1996) 305–311.
- [5] V.I. Kalchenko, I.A. Koshets, E.P. Matsas, O.N. Kopylov, A. Solovoyov, Z.I. Kazantseva, Yu.M. Shirshov, Calixarene-based QCM sensors array and its response to volatile organic vapours, *Mater. Sci.* 20 (3) (2002) 73–88.
- [6] A. Koshets, Z.I. Kazantseva, Yu.M. Shirshov, S.A. Cherenok, V.I. Kalchenko, Calixarene films as sensitive coatings for QCM-based gas sensors, *Sens. Actuators B* 106 (2005) 177–181.
- [7] B.C. Yadav, R. Srivastava, C.D. Dwivedi, Synthesis and characterization of ZnO–TiO₂ nanocomposite and its application as a humidity sensor, *Philos. Mag.* 88 (2008) 1113–1124.
- [8] G. Sauerbrey, Verwendung von Schwingquarzen zur Wagung dünner Schichten und zur Mikrowagung, *Z. Phys.* 155 (1959) 206–222.
- [9] L. Seals, J.L. Gole, L.A. Tse, P.J. Hesketh, Rapid, reversible, sensitive porous silicon gas sensor, *J. Appl. Phys.* 91 (2002) 2519–2523.
- [10] P.-G. Su, Y.-P. Chang, Low-humidity sensor based on a quartz–crystal microbalance coated with polypyrrole/Ag/TiO₂ nanoparticles composite thin films, *Mater. Sci. Eng. R* 61 (2008) 1–39.
- [11] A.P.M. Glassrod, Response of a quartz crystal microbalance to a liquid deposit, *J. Vac. Sci. Technol.* 15 (1978) 1836–1843.
- [12] S.H. Lee, D.D. Stubbs, J. Cairney, W.D. Hunt, Rapid detection of bacterial spores using a quartz crystal microbalance (QCM) immunoassay, *IEEE Sens. J.* 5 (2005) 737–743.

- [13] W.D. Hunt, D.D. Stubbs, S.H. Lee, Time-dependent signatures of acoustic wave biosensors, *Proc. IEEE* 91 (2003) 890–901.
- [14] Study of Viscoelastic Films – A Comparison between the Voigt Viscoelastic Model and the Saurbrey Relation, qsense, application notes.
- [15] M. Teresa, S.R. Gomes, P. Sergio, T. Nogueira, J.A.B.P. Oliveira, Quantification of CO₂, SO₂, NH₃, and H₂S with a single coated piezoelectric quartz crystal, *Sens. Actuators B* 68 (2000) 218–222.
- [16] N.K. Ali, M.R. Hashim, A. Abdul Aziz, Effects of surface passivation in porous silicon as H₂ gas sensor, *Solid State Electron.* 52 (2008) 1071–1074.
- [17] N. Goswami, P. Sen, Water-induced stabilization of ZnS nanoparticles, *Solid State Commun.* 132 (2004) 791–794.

Biographies

Neslihan Üzar received her BS degree and her MS degree in Physics from Istanbul University, Istanbul, Turkey in 2002 and 2006, respectively. She is working for her Doctor of Science degree at Istanbul University. She has been studying on nanostruc-

ture synthesizing and investigation of sensor properties of nanostructure. She won poster award on humidity sensing properties of ZnS nanostructures from E-MRS Spring Meeting 2010.

Salih Okur received his bachelor's degree in Physics Education from Hacettepe University in Ankara, Turkey in 1989, his master's degree in Physics from Ankara University in Ankara, Turkey in 1992, and master's degree in Physics from Illinois Institute of Technology (IIT) in Chicago, IL, USA in 1996, and his Ph.D. in Physics from IIT in 1998. He is currently an Associate Professor in the Department of Physics at Izmir Institute of Technology in Izmir, Turkey. His current research interests include SAM, LB, organic semiconducting thin film interfaces and their application to electronic devices such as organic photovoltaic, OLEDs, OTFTs, nano-dots, nano-wires.

Çetin Arıkan received his Ph.D. degree from University of Essex, UK in 1980. His Ph.D. thesis focused on mainly investigation of photoconductive properties of GaAs. Currently Çetin Arıkan is with Istanbul University as a Professor of Solid State Physics, he is actively continuing his research on characterizations and applications of the low dimensional semiconductors. His scholarly output includes papers published in refereed international journals, and refereed international conference proceedings.