

**IMPROVEMENT OF ENERGY PERFORMANCE
USING MODULAR GREEN SYSTEMS AS A
RETROFITTING STRATEGY ON BUILDING
ENVELOPE**

**A Thesis Submitted to
The Graduate School of Engineering and Sciences of
İzmir Institute of Technology
in Partial Fulfillment of the Requirements for the Degree of**

MASTER OF SCIENCE

in Environmental Engineering

**by
Balsam Munadhil Al CHADERCHI**

**July 2023
İZMİR**

We approve the thesis of **Balsam Munadhil Al CHADERCHI**

Examining Committee Members:

Prof.Dr. Sait Cemil SOFUOGLU

Environmental Engineering, Izmir Institute of Technology.

Prof.Dr. Glden GKEN AKKURT

Energy Systems Engineering, Izmir Institute of Technology.

Assoc.Prof.Dr. Zeynep DURMU ARSAN

Architecture, Izmir Institute of Technology.

Assist.Prof.Dr. Hale DEMIRTEPE

Environmental Engineering, Izmir Institute of Technology.

Assist.Prof.Dr. İlknur UYGUN

Interior Architecture and Environmental Design, Yasar University.

18 July 2023

Prof.Dr. Sait Cemil SOFUOGLU

Supervisor, Environmental Engineering
Izmir Institute of Technology.

Assoc.Prof.Dr. Zeynep DURMU ARSAN

Co-Supervisor, Architecture.

Prof.Dr. Sait Cemil SOFUOGLU

Head of the Department of
Environmental Engineering

Prof. Dr. Mehtap EANES

Dean of the Graduate School of
Engineering and Sciences

ACKNOWLEDGMENTS

I want to thank Allah for all the great opportunities I'm blessed with including the ability to conduct this thesis.

I would like to express my deepest gratitude and appreciation to my supervisors, Prof. Dr. Sait Cemil Sofuoğlu and Assoc. Prof. Dr. Zeynep Durmuş Arsan for their guidance, advice, and encouragement through this academic year, without their support and valuable comments, this thesis would not be conducted.

A great appreciation to Turkish State Meteorological Service for providing the weather data that is crucial for conducting the software simulation, without their generosity and valuable work this thesis could not be done. I would like to thank to IYTE Faculty of Architecture, Building Physics Laboratory for providing Onset HOBO U-10 datalogger for monitoring studies in E Block of the Faculty of Architecture. Many thanks to architect Gamze Kebeç in IYTE, Directorate of Construction and Technical Works for providing data of my case study building (E Block of the Faculty of Architecture) and being a reliable contact for data and information.

Furthermore, I would like to thank all my great professors at Izmir Institute of Technology for their role of the knowledge and awareness that I have today. Finally much gratitude to my family, for your support and help during my study specially my father Eng. Monadhil Abdul Jabar Alchadirchy and my mother Senaa Shehab who gave me the opportunity to obtain my master degree.

ABSTRACT

IMPROVEMENT OF ENERGY PERFORMANCE USING MODULAR GREEN SYSTEMS AS A RETROFITTING STRATEGY ON BUILDING ENVELOPE

The development of new infrastructure increases energy consumption consequently, the need for nature-based solution arises. Motivation for modular green systems (MGs) are rooted in making the existing buildings more environmentally friendly. This work aims to investigate MGs, prefabricated greenery systems as a retrofitting approach to minimize energy consumption in buildings. Initially, façade and roof alternatives were designed with different plants, materials, and sizes. The investigation covers two levels: firstly, the product level, i.e., life cycle analysis that entails evaluating the energy consumption and CO₂ footprint of the system. Plastic, recycled plastic, cork, and fiberglass module materials were evaluated using Granta Edupack for the stages of extraction, manufacture, transport, and disposal. Recycled plastic is the best in terms of environmental impact along its lifespan. Secondly, recycled plastic was applied with the retrofit alternatives for roof; RA1, RA2, and RA3 and façade; FA1, FA2, and FA3. Investigation on energy performance was conducted for an existing building, i.e., Faculty of Architecture, E block of IYTE using DesignBuilder software. Green roof and façade modules showed 4.46-6.52 % and 7.44-11.72 % heating consumption reduction range, respectively. Applying RA2 on all the roof area (ARA2) and FA3 on south façade (SFA3) save 12.65 % of 2773 kWh heating consumption and 1.60 % of 7555 kWh cooling consumption, ultimately saving 471.58 kWh on monthly average. To conclude, MGs can be an alternative to the retrofitting strategies due to providing lower environmental impact, reduced consumptions for heating energy on building basis and reduced cooling consumptions on city scale.

ÖZET

BİNA KABUĞUNDA GÜÇLENDİRME STRATEJİSİ OLARAK MODÜLER YEŞİL SİSTEMLER KULLANILARAK ENERJİ PERFORMANSININ İYİLEŞTİRİLMESİ

Yeni altyapının geliştirilmesi enerji tüketimini artırmaktadır. Bu nedenle doğa temelli çözümlere ihtiyaç duyulmaktadır. Modüler yeşil sistemlere (MYler) duyulan ilgi, mevcut binaları daha çevre dostu hale getirmesidir. Bu çalışma, binalarda enerji tüketimini en aza indirmek için bir iyileştirme yaklaşımı olarak prefabrik yeşil sistemler olan MY'leri araştırmayı amaçlamaktadır. İlk olarak, farklı bitkiler, malzemeler ve boyutlarla cephe ve çatı alternatifleri tasarlanmıştır. Araştırma iki aşamalıdır: ilki, ürün seviyesi, yani sistemin enerji tüketimini ve CO₂ ayak izini değerlendiren yaşam döngüsü analizidir. Plastik, geri dönüştürülmüş plastik, mantar ve fiberglas modül malzemeleri, hammadde eldesi, üretim, taşıma ve bertaraf aşamaları için Granta Edupack kullanılarak değerlendirilmiştir. Geri dönüştürülmüş plastik, yaşam süresi boyunca çevresel etkisi açısından en iyi malzeme olarak tespit edilmiştir. İkinci aşamada, geri dönüştürülmüş plastik, çatı için; RA1, RA2 ve RA3 ve cephe için FA1, FA2 ve FA3 iyileştirme alternatifleri ile uygulanmıştır. Enerji performans araştırması, mevcut bir bina olan IYTE Mimarlık Fakültesi, E Blok için DesignBuilder yazılımı kullanılarak yapılmıştır. Yeşil çatı ve cephe modülleri ile % 4.46-6.52 ve % 7.44-11.72 ısıtma için enerji azaltımı sağlanmıştır. Alternatif RA2'nin tüm çatı alanına (ARA2) ve FA3'ün binanın güney duvarına (SFA3) uygulanmasıyla 2773 kWh ısıtma yükünden % 12.65, 7555 kWh soğutma yükünden % 1.60, genel itibarla aylık 471.58 kWh tasarruf sağlanabileceği görülmüştür. Sonuç olarak, MY'ler, daha düşük çevresel etki, bina bazında azaltılmış ısıtma enerji tüketimi ve şehir ölçeğinde azaltılmış soğutma enerjisi sağlama potansiyeli nedeniyle yenileme stratejileri için bir seçenek olabilir.

TABLE OF CONTENTS

LIST OF FIGURES	viii
LIST OF TABLES.....	xi
LIST OF ABBREVIATIONS.....	xiii
CHAPTER 1. INTRODUCTION	1
1.1. Problem statement.....	4
1.2. Goals	5
1.3. Scope of the study	5
CHAPTER 2. LITERATURE REVIEW	7
2.1. Green systems	7
2.1.2. Previous theses	17
2.2. Green modular systems	17
2.3. Implementation	24
2.4. Softwares.....	25
2.4.1. DesignBuilder/EnergyPlus	25
2.4.2. Granta CES Edupack.....	27
2.5. Practical review	29
CHAPTER 3. MATERIALS AND METHODS	32
3.1. Case Building.....	33
3.2. Life cycle analysis	40
3.3. Energy performance analysis.....	40
CHAPTER 4 ALTERNATIVES	42
4.1. Roof Alternatives	42
4.2. Façade Alternatives.....	44

CHAPTER 5. LIFE CYCLE ASSESSMENT	47
5.1. Input	47
5.2. Output.....	49
5.2.1. Recycled Plastic.....	49
5.2.2. Cork	51
5.2.3. Fiber glass.....	52
5.2.4. Normal plastic	54
5.3. Discussion	56
 CHAPTER 6. ENERGY SIMULATION SCENARIOS	 59
6.1. Input	59
6.1.1. Weather File	59
6.1.2. Calibration of the Model	62
6.1.2.1. Measurements.....	63
6.1.2.2. Calibration protocol.....	65
6.1.3. Activity	68
6.1.4. Construction	70
6.1.5. Effect of MGs on thermal properties of envelope	72
6.1.6. HVAC.....	73
6.2. Base case	74
6.3. Roof.....	77
6.4. Façade	81
6.4.1. Single facades	85
6.4.2. Short vs long facades.....	94
6.5. Limitation.....	101
6.6. Discussion	101
 CHAPTER 7. CONCLUSION	 105
 REFERENCES	 106

LIST OF FIGURES

<u>Figure</u>	<u>Page</u>
Figure 1. Izmir temperature data (2010-2022)(WorldWeatherOnline.com)	3
Figure 2. Projections of monthly mean temperatures for Izmir city (Yıldız, 2016).	3
Figure 3. The correlation of different impacting parameters.....	5
Figure 4. Flowchart of thesis	6
Figure 5. Components of green roof. (Berardi et al., 2014)	7
Figure 6. Classification of vertical greening systems. (Ottelé et al., 2011).....	19
Figure 7. Modular system visualization. (Hejl et al., 2020)	20
Figure 8. Schematic section of modular green roof system. (Loiola et al., 2019).....	21
Figure 9. Green system's pros vs cons.	25
Figure 10. Local buildings with green system. (Braun, 2015) (Archello, 2010) (ODS, 2022) (ELİNÇ et al., 2013) (Samu, 2016)	29
Figure 11. International buildings with green system. (Velazquez, 2014) (urbanNext, 2023) (Land8, 2016) (Land8, 2016) (ArchDaily, 2015).....	30
Figure 12. Thesis Methodology.	32
Figure 13. Location of the case study (Google maps)	33
Figure 14. Sun path analysis of the case study.	34
Figure 15. Case study building ground floor plan. (IYTE Directorate of construction and technical works).....	34
Figure 16. Case study building first floor plan. (IYTE Directorate of construction and technical works).....	35
Figure 17. Case study building basement floor plan. (IYTE Directorate of construction and technical works)	35
Figure 18. Monthly energy consumption (kWh).	37
Figure 19. Annual energy consumption (kWh).	37
Figure 20. Section showing facade-slab connection. (IYTE Directorate of construction and technical works)	39
Figure 21. Building facades.	39
Figure 22. Level 1 method to evaluate the efficiency of the product over its lifespan...	40
Figure 23. Methodology of energy simulation.	41

Figure 24. Schematic distribution of roof green modules on the building.	43
Figure 25. Modular roof system layers and components. (Sedum Green Roof, 2022) ..	44
Figure 26. Schematic distribution of MGs for each facade on the building.	45
Figure 27. Modular facade system layers and components.(Greening Solution, 2023).	46
Figure 28. Raw materials of (A) Plastic, (B) Cork and (C) Fiberglass as alternatives for LCA (Granta Edupack).....	49
Figure 29. Energy consumption for recycled plastic. (Granta Edupack).....	50
Figure 30. CO ₂ emissions for recycled plastic. (Granta Edupack).....	50
Figure 31. Energy consumption for recycled cork. (Granta Edupack).....	52
Figure 32. CO ₂ emissions for cork. (Granta Edupack).....	52
Figure 33. Energy consumption for fiberglass. (Granta Edupack).....	53
Figure 34. CO ₂ emissions for fiberglass. (Granta Edupack).....	54
Figure 35. Energy consumption for normal plastic. (Granta Edupack).....	55
Figure 36. CO ₂ emissions for normal plastic. (Granta Edupack).....	55
Figure 37. Cost analysis of module materials. (Granta Edupack)	56
Figure 38. Energy consumption of plastic, recycled plastic, cork, and fiber glass over their lifespan. (Granta Edupack).....	57
Figure 39. CO ₂ emissions of plastic, recycled plastic, cork, and fiber glass over their lifespan. (Granta Edupack)	58
Figure 40. Daily line graphs of (A) temperature (°C), (B) pressure (hPa), (C) wind speed (m/s), (D) wind direction (degree) and (E) relative humidity (%) for 05.01- 05.02.2023	60
Figure 41. Location of the datalogger in (A) plan and (B) the meeting room.....	64
Figure 42. Daily averages of monitored (A) Temperature & (B) Relative humidity (HOBO U-10)	65
Figure 43. Hourly temperature data monitored vs simulated	67
Figure 44. Example of activating green roof feature for a roof alternative.	73
Figure 45. Software views of the base simulation model. (DesignBuilder).....	74
Figure 46. Software Plan of (A) basement, (B) ground, and (C) first floor. (DesignBuilder)	75
Figure 47. Cooling and heating consumption graph of base case scenario.	77
Figure 48. Heating consumption graph of roof green module scenarios.....	79
Figure 49. Heating consumption graph of roof green module scenarios for certain months.....	79

Figure 50. Cooling consumption graph of green roof module scenarios.....	80
Figure 51. Cooling consumption graph of green roof module scenarios for certain months.....	81
Figure 52. Heating consumption graph of green facade module scenarios.....	83
Figure 53. Heating consumption graph of green facade module scenarios for certain months.....	83
Figure 54. Cooling consumption graph of green facade module scenarios.....	84
Figure 55. Cooling consumption graph of green facade module scenarios.....	85
Figure 56. Monthly heating consumption for East facade simulations.	88
Figure 57. Monthly heating consumption for West facade simulations.	88
Figure 58. Monthly heating consumption for South facade simulations.....	89
Figure 59. Monthly heating consumption for North facade simulations.....	89
Figure 60. Annual heating consumption for single facades simulations.	90
Figure 61. Monthly cooling consumption for East facade simulations.	92
Figure 62. Monthly cooling consumption for West facade simulations.....	92
Figure 63. Monthly cooling consumption for South facade simulations.....	93
Figure 64. Monthly cooling consumption for North facade simulations.....	93
Figure 65. Annual cooling consumption for single facades simulations.....	94
Figure 66. Monthly heating consumption for long and short facades simulations.....	97
Figure 67. Annual heating data for long and short facades simulations.....	97
Figure 68. Monthly cooling consumption for long and short facades simulations.....	100
Figure 69. Cooling data for long and short facades simulations.	100
Figure 70. Heating consumption reduction percentage for all scenarios.....	103
Figure 71. Cooling consumption reduction percentage for all scenarios.	104

LIST OF TABLES

<u>Table</u>	<u>Page</u>
Table 1. Summary and findings of literature review.	15
Table 2. Main layers of green roof. (Hui & Chan, 2008)	23
Table 3. Buildings in & outside Türkiye with green systems.....	31
Table 4. Case study building energy consumption data (kWh). (IYTE Directorate of construction and technical works)	36
Table 5. Detailed construction of building’s components. (IYTE Directorate of construction and technical works)	38
Table 6. Roof alternatives of the study. (DesignBuilder, 2023; YU, 2006)	44
Table 7. Facade alternatives of the study. (DesignBuilder, 2023; YU, 2006).....	46
Table 8. Details of data input in Granta Edupack LCA software.	48
Table 9. Results of LCA for recycled plastic. (Granta Edupack).....	50
Table 10. Results of LCA for cork. (Granta Edupack).....	51
Table 11. Results of LCA for fiberglass. (Granta Edupack)	53
Table 12. Results of LCA for normal plastic. (Granta Edupack)	54
Table13. Properties of HOBO U-10 data logger.	64
Table 14. Calibration used values and results.....	67
Table 15. Daily temperature for monitored and simulation data.....	67
Table 16. General and lighting activity schedule. (DesignBuilder)	69
Table 17. Input data for Designbuilder.....	70
Table 18. Base structural components thermal properties.....	71
Table 19. Thermal properties of MGs.	72
Table 20. Cooling and heating consumption of base case scenario. (DesignBuilder)....	76
Table 21. Roof simulation scenarios.....	77
Table 22. Heating consumption of roof green module scenarios. (DesignBuilder)	78
Table 23. Cooling consumption of green roof module scenarios. (DesignBuilder).....	80
Table 24. Facade’s simulation scenarios	81
Table 25. Heating consumption of green façade module scenarios. (DesignBuilder) ...	82
Table 26. Cooling consumption of green façade module scenarios. (DesignBuilder) ...	84
Table 27. Single facades simulation scenarios.	85

Table 28. Heating consumption for single facades simulations.	87
Table 29. Cooling consumption for single facades simulations.	91
Table 30. Short vs long facades simulation scenarios.	94
Table 31. Heating consumption for long and short facades simulations.	96
Table 32. Cooling consumption for long and short facades simulations.	99

LIST OF ABBREVIATIONS

UHI:	Urban Heat Island
SUHI:	Surface Urban Heat Island
GHG:	Green House Gas
UN:	United Nation
NbS:	Nature based Solution
LCA:	Life Cycle Analysis
HIR:	Heat Island reduction
VGS:	Vertical Green System
ICB:	Expanded Cork Board
GL:	Graphics Library
CAD:	Computer-Aided Design
BIM:	Building Information Model
FAAST:	Flexible Architecture Standard System Technology.
FRP:	Fibre-Reinforced Plastic
LAI:	Leaf Area Index
RMSE:	Root Mean Square Error
MBE:	Mean Bias Error
MGS:	Modular Green System
HVAC:	Heating, Ventilation and Air Conditioning
CoP:	Coefficient of Performance
SHGC:	Solar heat gain coefficient
K:	Kelvin

CHAPTER 1

INTRODUCTION

According to (Besir & Cuce, 2018) and (Ayas, 2020) the building industry consume 40 % of energy production and emit 36 % of the total greenhouse gases. That is why buildings are an important target for energy savings against climate change. The urgent cause of improving building performance is stated by (Hejl et al., 2020) because nearly every decade, the number of new structures increases significantly. As a result, there is less vegetation in urban and suburban areas, which leads to the development of heat islands—urban areas that are hotter than the rural areas around them. A metropolis with 1 million or more residents can have an annual mean air temperature that is up to 4.4°C warmer than the nearby rural areas. To illustrate, in a review by (Hejl et al., 2020), according to a report, heat islands cause an increase in summer energy use that raises air temperature by 0.6°C and power use by 5–10% more than in rural regions. The temperature difference between evening and nighttime can reach 12°C, which undoubtedly has a significant impact on city life, particularly during the summer. High levels of sulfur dioxide (SO₂), nitrogen oxides (NO_x), carbon monoxide (CO), and other atmospheric pollutants are released.

Human health and comfort are also impacted by the rising temperatures. The problem was investigated at a local level by (Dihkan et al., 2018). Both atmospheric UHI (urban heat island) and surface UHI were determined to be a significant environmental issue for Istanbul, Bursa, Ankara, Izmir, Gaziantep, Erzurum, and Trabzon between 1984 and 2011. The changing land use/cover structure, together with anthropogenic pressure on and interference with city planning geometry, may have contributed to the UHI problem in Türkiye. In Izmir south, north and east subregions the magnitude of SUHI (surface urban heat island) increased from 3.06, 2.86, and 2.76 to 3.52, 3.10, and 2.84, respectively over the period of 2000-2011. Official statistics of temperature data in Izmir from 2010 to 2022 is shown in Figure 1. (Elbir et al., 2000) constructed a national emission inventory for five major pollutants: particulate matter (PM), SO_x, NO_x, non-methane volatile organic compounds, and CO, which indicated that Türkiye was a somewhat large emission source at the European scale, even if emission indicators on unit

area and per capita were shown to be significantly lower in magnitude. Air pollution levels in several of Türkiye's largest cities were also assessed using data from existing national monitoring programs. Results indicated that, particularly during the winter months in Turkish cities, the air quality standards were not being reached. In addition, (United Nations, 2021) reported that in 2019, fossil fuel emissions in Turkey were mostly caused by the burning of coal, followed by the combustion of oil and natural gas. Over 70% of Turkey's GHG emissions in that year came from the energy sector, primarily from the production of electricity. This issue extends to global level where (Timperley, 2021) indicates that Türkiye's GHG (greenhouse gasses) emissions are not keeping up with the Paris Agreement's target of keeping temperature increases below 2 °C. Climate Action Tracker predicts that by 2030, COVID-19 pandemic-related emissions in the country would continue their increasing trend and rise by 40% to 70% over the level of 2020.

Among the latest actions against UHI that consider energy consumption and excess emissions (Birpınar, 2019; REN21, 2020; Thomson Reuters Foundation, 2019), Türkiye was a co-leader of the group discussing zero-carbon buildings at the 2019 UN Climate Action Summit. For instance, the city of Eskişehir has committed to converting all present structures to zero emissions by 2050, and in support of this initiative (Altaeb, 2021) stated that Türkiye is aiming for net zero carbon emissions by 2053. This goal is in line with what (European Environment Agency, 2015) indicated as a guide of according to the European Environment Agency, metropolitan populations are regularly exposed to air pollution levels over the allowable standards, making it necessary to develop measures to lessen this issue. The traditional strategy for combating air pollution is to reduce its sources, such industrial emissions and traffic. To help eliminate the air contaminants already present in metropolitan areas, creative methods can be used.

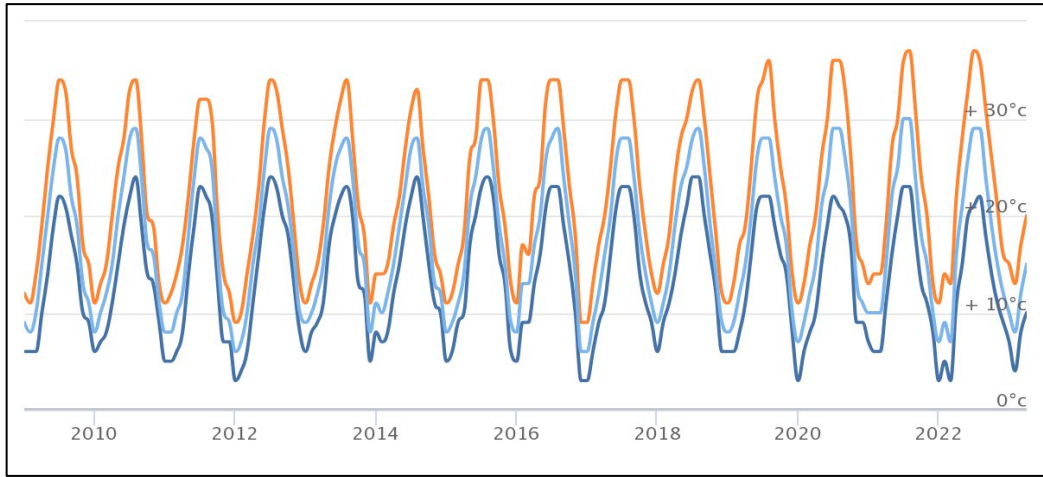

Figure 1. Izmir temperature data (2010-2022)(WorldWeatherOnline.com)

Izmir has a Mediterranean climate; therefore, it's winters are moderate and wet while its summers are scorching and dry. Nevertheless, as indicated in Figure 2 there is a clear half and half division over the year between cold and hot weather making both heating and cooling consumptions important to consider. The projections indicate that retrofitting needs to be considered to stabilize the city temperature.

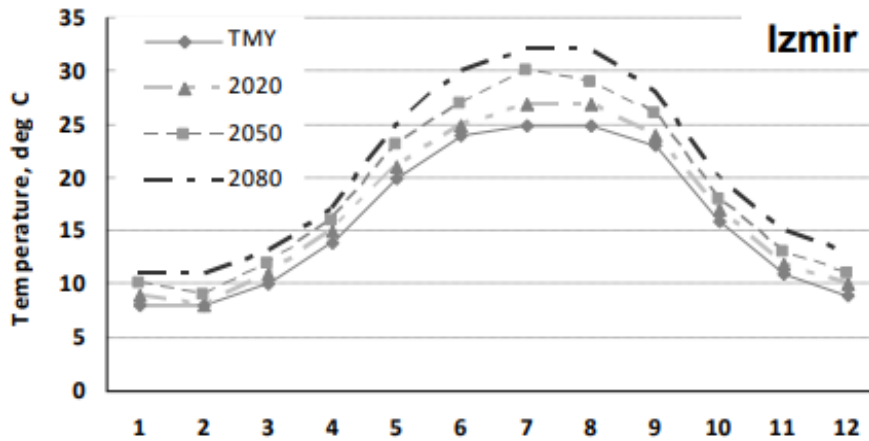

Figure 2. Projections of monthly mean temperatures for Izmir city (Yıldız, 2016).

According to (Cohen-Shacham et al., 2019) and (Ibrahim & Al-Chaderchi, 2022) Nature-based solutions (NbS) are initiatives to protect, sustainably manage and restore natural or modified ecosystems that successfully and adaptably address societal issues

while simultaneously enhancing biodiversity and human well-being. The practice of biophilic design is the practical terms and is referred to as the idea of establishing deep linkages between both built and natural environments, has grown dramatically over the past ten years due to the global phenomenon of climate change and the increasingly expanding environmental crises. As a result, biophilic design is now often used in environmentally friendly contexts. People had limited access to green public places and little interaction with nature during the COVID 19 lockdown, but the modern built environment has begun to show an increased interest in incorporating nature into design and minimizing people's negative impact on the environment.

(Seddon et al., 2020) emphasizes the critical requirement for natural and social scientists to interact with decision-makers as climate policy increasingly favors methods of removing greenhouse gases, such as afforestation. They must ensure that NbS can follow through on their pledge to solve the biodiversity and climate problems while advancing sustainable development. The need for more systems and approaches to allow survival of nature among our living areas is becoming more and more urgent as the world population and urbanization levels increase. The incorporation of green systems into our existing urban fabric is long overdue and can be effective in making what we have better.

1.1. Problem statement

There are a huge number of buildings around the world, and each have a great impact on the environment. The building industry consume 40 % of global energy production and emit 36 % of the total greenhouse gases. The energy consumption and emissions of the usage and construction of buildings put a great pressure on earth resources and wellness. The development of new infrastructure leads to increased energy consumption, notably electrical usage, consequently the need for nature-based solution arises. A renewable asset to buildings is required to reduce the pressure on depleting resources that affect many aspects such as temperature and air quality as shown in Figure 3. Conventional green systems are renewable and considered a passive approach, nevertheless they lack the flexibility to add value to existing structures, it requires its own system from the start, thus making it unviable option for retrofitting. This issue is

addressed by this thesis investigation of modular green system as a retrofitting approach to reduce the existing building's environmental impacts.

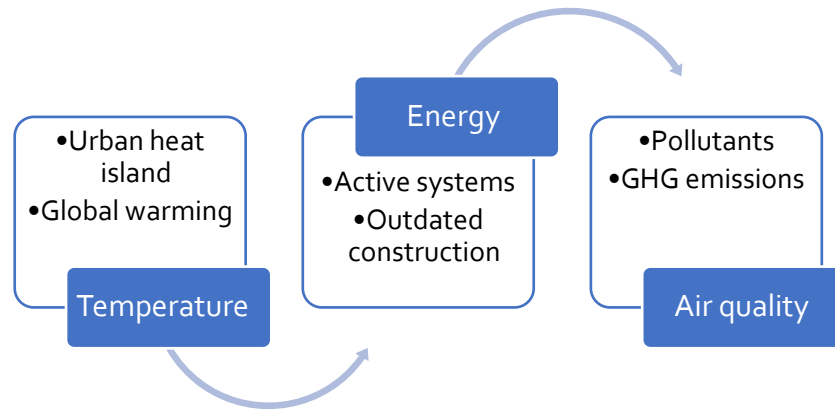

Figure 3. The correlation of different impacting parameters.

1.2. Goals

Introduce Modular green system as an efficient retrofitting approach that:

- 1 Causes minimum to no disturbance to the existence structure of the building
- 2 Has minimal impact on the environment from production to end of life
- 3 Reduce energy consumption for heating and cooling of the building.

1.3. Scope of the study

This study investigates the modular green systems as a retrofitting approach as shown in Figure 4. Several materials and plants are tested to determine the optimal module design. The measuring parameters are the efficiency of the system as a product

from manufacturing to end of life (LCA) using Edupack software and its impact on building's energy performance using DesignBuilder.

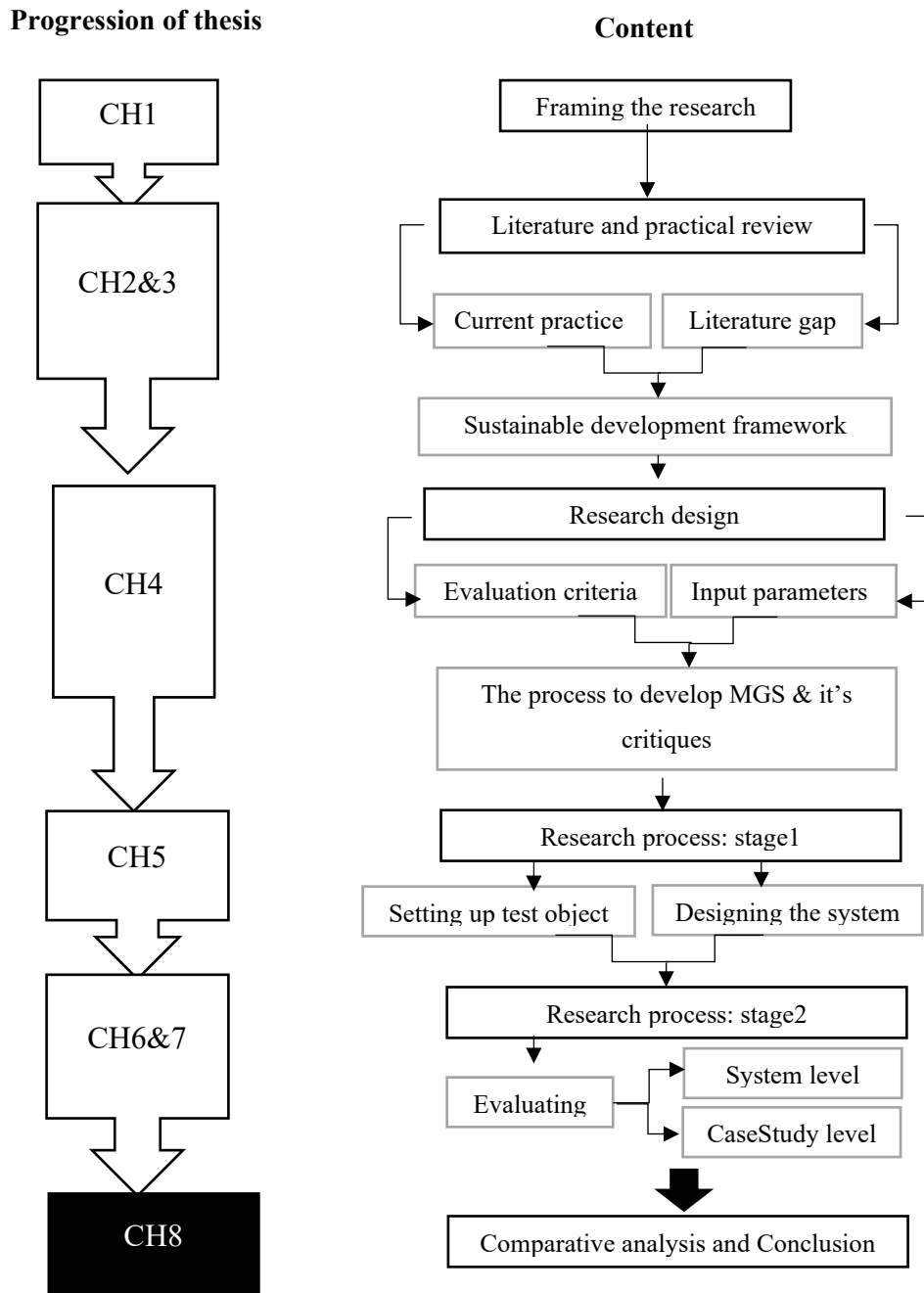

Figure 4. Flowchart of thesis

CHAPTER 2

LITERATURE REVIEW

2.1. Green systems

Nowadays, green envelope technology is becoming more and more well-liked for a variety of environmental reasons, including lowering energy usage for active heating and cooling systems, collecting rainwater, and decreasing the effects of overheated buildings. The comfort of the living space, the reduction of air pollution, and even noise absorption are secondary benefits of using green technologies. Additionally, it serves as an insulation and thermal mass to shield the waterproofing material, an essential component of roofing construction, from heat buildup and radiation, hence extending the material's lifetime. According to (He et al., 2016) and (Berardi et al., 2014) Plants (landscape components), a substrate (growing media), a filter, a moisture-retentive drainage material, a root barrier, a waterproof membrane, an insulating layer, and a structural layer are the various elements that make up a green roof design as illustrated in Figure 5. Depending on the depth of the substrate and the plants employed, green roofs can be characterized as intensive, semi-intensive, or extensive.



Figure 5. Components of green roof. (Berardi et al., 2014)

These classifications are explained by (Emilsson, 2008) and (Besir & Cuce, 2018) Intense green roofs may accommodate a range of plants, including shrubs, bushes, and small trees because they have a thicker substrate layer (around 15 to 40 cm). However, they need constant irrigation and upkeep.

The aesthetics of inaccessible roofs can be improved with extensive green roofs, which are lightweight systems that can be put in existing flat or sloped roofs up to 30. The variety of plants in extensive solutions is constrained by their thickness (6–20 cm). Several studies suggest using succulent plants, like Sedum, because of their small roots, compatibility with scarce water resources, and endurance to sun radiation.

The choice of green roof value to a certain project has to be determined by several parameters that (Rosasco & Perini, 2019) referred to such as :

1. Economic: Expenses of installation, upkeep, tax breaks, real estate advantages, and energy savings.
2. Environmental: Resource Sustainability, Embodied Energy and Carbon Emission Reduction, Air Quality, and Urban Heat Island Reduction.
3. Social: Health, Urban Aesthetics, and Building Aesthetics.
4. Performance: Insulation properties, system weight, roof longevity, and acoustic noise reduction.

(Dachbegrünungen, 2018) suggest that for retrofitting purposes Since these solutions do not place an undue burden on the existing structure, extensive green roofs are preferable to intense green roofs. Green roofs that are semi-intensive or simple intense have intermediate qualities, such as a thicker substrate (12–25 cm) than extensive ones but fewer watering and care requirements than intensive ones. The dramatic change in climate in cities is inevitable, (Alexandri & Jones, 2008) explains that Urban environments no longer have the same climatic characteristics as rural regions because to the size, construction, materials, and overall absence of greenery in modern cities. These modifications directly affect the local climate of urban areas, particularly in the city's center, leading to the heat island effect, which is characterized by a marked increase in the temperature of the city. In particular for cities in regions with a pronounced hot season, this may result in major local climatically uncomfortable circumstances and potentially endanger human health. The existence of human-made green areas dates back to 500 BC, the Hanging Gardens of Babylon, admitted as the earliest examples of greenery systems (Vijayaraghavan, 2016).

These systems were also used by the Roman and Greek empires during their respective times, just like Babylon. In the Mediterranean area, various plants, particularly vines, were used to shade building envelopes from midsummer sunshine and to give inhabitants cooler, more pleasant inside environments. (Manso & Castro-Gomes, 2015) mentions that In the UK and Central Europe during the 17th and 18th centuries, the use of plants climbing buildings significantly increased. During the 19th century, decorative features were the main draw for urban dwellers in European and North American towns, making woody climbers the most often employed kind of greenery for building surfaces. Urban residents at the turn of the 20th century generally agreed that living walls and green roofs were incompatible with contemporary construction because they were difficult to fix. (Cuce, 2017).

The advancement of technology, increasing occupant comfort levels, and a growing social consciousness of environmental problems have kept greenery systems in the forefront of attention year after year. Green roofs and facades now have a considerable potential to provide energy savings in the construction sector and enable thermally appealing and pleasant indoor and outdoor settings, as is widely established in the literature. The implementation of green systems is economically unappealing at first sight as the high savings in long term is overlooked because it takes time. Thus, there is a global hesitation to implement green systems, the obvious benefits have started to show through research (CHAPTER 2) and practical implementation (CHAPTER 3). The achievements clearly indicate that green roofs can lower summer heat transfer via building roofs by around 80 % (Besir & Cuce, 2018). In the summer, it is said that green roofs are associated with between 2.2 and 16.7 % less energy than conventional roofs. In the winter, it is discovered that there is a 4 °C temperature difference between standard and green roofs. The amount of vegetation has a significant impact on how much energy a building consumes in the summer, with extensive, semi-intensive, and intense greenery surfaces needing, respectively, 23.6, 12.3, and 8.2 kWh/m²/year. It is significant that 98 m² of vertical greenery system's annual average CO₂ accumulation ranges from 13.41 to 97.03 kg carbon/m². (Besir & Cuce, 2018). A technical study by (Akbari & Konopacki, 2005) estimated both direct impacts (reduced heat input via the building shell) and indirect effects (lower air temperature) that result in cost savings. Over 75 % of the overall savings for residential, business, and retail buildings came directly from the impacts of cool roofs and shade trees. The possible overall HIR (Heat Island reduction) reductions for residential buildings heated by gas varied from around 12% to nearly 25%. The overall

HIR savings potential for gas-heated office buildings ranged from roughly 7% to nearly 18%. The overall HIR savings potentials for gas-heated retail buildings ranged from around 7 % to nearly 14 %, The overall HIR savings potentials for gas-heated office buildings ranged from roughly 7 % to nearly 18 %. Also according to (Rosenzweig et al., 2006) the usage of green roofs has a tremendous potential for reducing heat. The researchers used the premise that all city roofs will be converted to green roofs when modeling air temperature decreases 2 m above the city's roof surface. According to the findings, the city as a whole had a daytime temperature decrease of 0.2 °C on average as walls and roofs are covered with plant, air and surface temperatures considerably drop in a variety of climates as compared to plain concrete roofing. (Abdin et al., 2018; Alexandri & Jones, 2008)

The convective, conductive, evaporative, and radiative heat fluxes are very different, between the green and concrete roofs. Compared to the convective heat exchanges between the air and the solid concrete roof, those that occur between the air and the grass are less strong. The overall radiative heat flux density on the concrete roof ranges from 158 to 355 W/m², whereas it ranges from 39 to 230 W/m² on the green roof. Because of the diffusion of radiation inside the plant layer, the total radiative heat exchanges on the vegetated surface are lower than on the concrete roof. When roofs are vegetated, air masses from the vegetated roofs enter the canyon significantly colder. On the other side, air masses enter the canyon heated by the plain roofs, which absorb the significant amounts of summer insolation, when only the walls are covered with plant. As a result, in Hong Kong, the drops in canyon air temperature were found to reach a high of 8.4 °C and an average of 6.9 °C throughout the day in the green-all condition, whereas they were only 3.9 and 2.5 °C, respectively, in the green-wall case (Alexandri & Jones, 2008).

The most appealing factor to investors and governments which are the main funding entities for the buildings sector is money leading (Manso et al., 2021) and (Jayasooriya et al., 2017) to include it as a main parameter and present an overview of the most important findings in relation to the advantages and disadvantages of green walls and roofs. Results indicate 100 %, 67 %, and 84 % cooling energy saving potential, and 73 %, 68 %, and 7 % heating energy saving potential for extensive, semi-intensive, and intensive green roof, respectively, with average 40-year lifespan, while green Facades and living walls has 34 %-66 % cooling energy saving potential with a 50-year average lifespan. The latter study indicated that compared to trees and green walls, green roofs

offered the greatest energy savings. The combination of green walls and roofs has produced the biggest yearly energy savings for the study area, 3324 MWh, which is equal to a financial gain of \$1,160,076. In Victoria, brown coal, which is regarded as a major contributor to GHG emissions, is used to generate the majority of the city's power. As a result, cutting back on energy consumption can indirectly help with air quality and GHG emissions. The ability of green system to pay for itself is what makes it a valid business plan as indicated by (Rosasco & Perini, 2018) showing that when a tax credit for installation expenses is taken into account, a VGS (Vertical Green System) may be economically viable; in this scenario, the Net Present Value and Internal Rate of Return are both positive, and the Pay Back Period is less than the lifespan of the VGS. The amount of energy saved for summer air conditioning in buildings as a result of the drop in outside air temperature is also significant.

On warm days, the protected walls' daytime temperatures were up to 9.0 °C colder than the corresponding values for the exposed wall. The vegetated walls' overnight temperatures during the chilly days were up to 3.5 °C higher than those of the control wall. The cooling effects of three distinct climbing plants as a part of direct and indirect green façades through shadowing and transpiration was estimated to lower the surface wall temperatures by up to 15.5 °C when compared to bare walls selected as the control. (Hoelscher et al., 2016) (Vox et al., 2018).

Air quality parameter was the focus of (Rowe, 2011) stating that pollutants are removed by plants in a number of ways. Through their stomates, plants absorb gaseous pollutants, their leaves trap particle debris, and their tissues and soil are able to break down certain organic molecules, such as polyaromatic hydrocarbons. Additionally, they indirectly minimize air pollutants by providing shade and decreasing surface temperatures through transpiration cooling, which in turn reduces photochemical processes that produce pollutants like ozone in the atmosphere. Another study that supports the fact that green systems boost air quality was conducted by (Sheweka & Magdy, 2011) and (Perini et al., 2011) saying that adding more vegetation to building facades may improve indoor air quality and lower surface temperatures. Plants unquestionably contribute to thermal comfort by transpiring heat away from the surrounding area and cooling the building's façade. This may be inferred from the study's observation that the outside environment stayed in the thermally comfortable range. Plants maintain equilibrium between relative humidity and temperature, which modifies the outdoor thermal comfort. Thus, even if green walls don't function as a shade device, they may nevertheless improve the air

quality and temperature in an area. The latter concludes that the major ways that vegetation improves air quality are through the uptake of gaseous pollutants like the absorption of minute dust particles, CO₂, NO₂, and SO₂. While carbon dioxide is utilized by plants for the photosynthesis that results in oxygen and biomass, nitrogen and sulfur dioxides are converted into nitrates and sulfates in the plant tissue. (Jaffal et al., 2012) state that the study of various interrelated processes, such as heat and mass transport and plant physiology, is necessary in order to describe the thermal behavior of green roofs. The literature has a variety of models for green roofs. The basic model considers the roof U-value. But there are many factors that impact the performance of green system according to (Manso et al., 2021), which are the physical characteristics of the building (height, insulation, construction materials, building envelope, glazing area, solar orientation, shading), the local climate conditions (seasons, heating or cooling requirements), and the materials of each layer and connection to the building.

(Santamouris et al., 2007) Investigated the performance of green roof system through several parameters and tools: Indoor air temperature calculations and Thermal performance calculations via TRNSYS 15.1 simulation program. The experimental work included: The indoor air temperature, Relative humidity, The outdoor air temperature, and surface temperature. The energy performance assessment found that the building's summer cooling requirements were much decreased. For the whole structure, this decline ranged from 6-49 %, and for the final plot, it was between 12 and 87 %. (Sailor, 2008) has physically modeled the energy balance of a vegetated rooftop and incorporated it into the EnergyPlus building energy simulation tool. The energy model may examine several green roof design options with the use of this module, including growth media depth and thermal properties as well as vegetation characteristics like plant kind, height, and leaf area index. The model has been tested successfully using information from a monitored green roof. The energy-saving effectiveness of a green roof for an Athens, Greece, building showed that a green roof reduced electricity consumption for air conditioning in the summer by around 40%, but the findings did not show any discernible reductions in heating consumption. (Sfakianaki et al., 2009; Spala et al., 2008)

In cases of retrofitting existing buildings, (Castleton et al., 2010) studied the body of research in order to investigate the greatest energy-saving potential of roof greening. They came to the conclusion that aging buildings with subpar insulation benefited most from a green roof. A green roof's impact on annual energy use in modern buildings with high-standard insulating layer standards was minimal.

One of the easiest ways to measure how effectively a green roof saves energy is by cooling. (Ouldboukhitine et al., 2012) (Nardini et al., 2012) have measured the change in cooling to examine the efficacy of the green roof. Different geographical areas, greening practices, plant types, and substrate compositions might all have an impact on how well the cooling works. (Hien et al., 2007) examined the difference in temperature for a green roof on a Singaporean building before and after greening. The results showed that the green roof's surface temperature was significantly reduced, particularly for roofs with high plant coverage, which resulted in a maximum temperature differential of roughly 18 °C. Additionally, the efficiency of various plants may vary. The degree of the temperature change (drop) grew along with the coverage's overall extent (Li & Yeung, 2014).

Green roofs not only improve air quality but also considerably lower runoff. Plants in the ground and on roofs may clear runoff, delay a storm's peak, and purify the air. In addition to raising the concentration of the element phosphorus from fertilizer that is put to them, green roofs also act as a sink for the elements nitrogen, lead, and zinc that are present in precipitation. By increasing the pH from 5 to 6 in rainwater to above 7 or 8, green roofs can help lessen the impacts of acid rain. (Yang et al., 2008) quantified a total of 1675 kg of air pollutants was removed by 19.8 ha of green roofs in one year with O₃, NO₂, PM₁₀, and SO₂ accounting for 52, 27, 14, and 7 % of the total amount. The authors further added that one square meter of green roof could offset the annual particulate matter emissions of one car. The cooling and energy saving potentials are well studied in many papers through virtual models and assumptions. The main concern is relating the findings to an existing building otherwise the calculations made, and simulation conducted are comprehensive in nature.

The LCA (life cycle analysis) of the system itself can be very important in case of retrofitting scenario because it is an independent assessment of a building component and can be evaluated properly. When applying a green system, the initial cost may mean too much for the decision makers so an LCA can show how and when this cost can be returned, and savings starts to activate in terms of energy. Environmental values are an important target in conducting LCA specially in governmental level where these analyses are considered a valid variable in addressing local and nationwide problem such as CO₂, pollution, and temperature levels. One runs the danger of undervaluing the intangible advantages that VGS give, like as CO₂ absorption, biodiversity, run-off, etc., by concentrating solely on the environmental effects of the usage stage. The possible

conflicts between sustainability, development standards, and the need to foster resilience are highlighted by this topic, especially when land is prioritized. (Kim et al., 2016) (Chafer et al., 2021) For both Mediterranean and temperate climates, the energy advantages given by the greening alternatives have a significant impact on the LCA; for the Mediterranean climate, the benefits assessed are nearly two times larger thanks to the energy benefits, i.e., savings resulting from the potential for cooling. When a building's energy requirement can be decreased or its ability to serve more than one purpose thanks to the incorporation of flora may be boosted, the materials used to create it are crucial for the environment. (Ottelé et al., 2011) (Bianchini & Hewage, 2012; Kosareo & Ries, 2007)

The literature reviewed in this section has a solid ground on the important parameters of the topic where energy savings, temperature, and air quality were considered in most papers. The parameters, methodologies, results and author comments are indicated in Table 1. In general, there is a need for more software methods; thus, the findings of these papers are not always supported by both experimental and simulation findings. In addition, a realistic view such as application criteria or case study is necessary to validate the methodology and the hypotheses of the literature which is surprisingly lacking.

Table 1. Summary and findings of literature review.

Reference	Focus parameters	Methods		Results	Gap
		Software	Other		
(Jaffal et al., 2012)	Energy performance Thermal comfort	TRNSYS EnergyPlus	Mathematical model	The yearly energy consumption was decreased by 6 % while the summertime interior air temperature was lowered by 2 °C.	The study needs some practical data logging to validate temperature values.
(Santamouris et al., 2007)	Energy performance	None	Mathematical model	the building's summer cooling burden being significantly reduced. This decrease varied from 6-49% for the entire building and 12-87% for the last story.	Calibration and more than one tool is required to support the findings.
(Sailor, 2008)	Energy performance	EnrgyPlus	None	According to building location (climate), energy usage was shown to vary greatly. As a result, it is clear that the green roof simulation tool described here can help to influence green roof design choices.	To back up the findings they are to be compared to filed measurements or test run.
(Sfakianaki et al., 2009)	Energy performance Indoor thermal comfort	TRNSYS	Experimental	Green roofs have a negligible impact on the heating needs of insulated structures operating in a Mediterranean environment. There has been calculated to be an 11% reduction in cooling demand. In free-floating structures during the summer, green roofs help to increase thermal comfort. Nearly 0.61 °C is the greatest predicted drop.	None
(Spala et al., 2008)	Energy and thermal performance	TRNSYS	Mathematical model	Green roofs greatly lessen the building's cooling burden during the summer, which is thought to contribute an additional 40% to energy savings.	There is no explanation to how the green roof can be applied to the case study.

(cont. on next page)

Table 1 (cont.).

Reference	Focus parameters	Methods		Results	Gap
		Software	Other		
(Ouldboukhitine et al., 2012)	Thermo-physical, moisture storage and microstructural soil characterizations	None	Experimental and mathematical model	With the substrate's water content, the thermal conductivity rises. There is a void between the water content decreasing with temperature in the intermediate phase of desorption.	The results must be validated through a real building test.
(Nardini et al., 2012)	Temperature Water runoff	None	Experimental	A) Green roofs significantly lower the heat consumption over the rooftop, with the substrate depth having a major impact and the vegetation having no discernible influence. B) The water content of the substrate has a significant impact on thermal effects. C) Green roofs have a major impact on substrate vegetation and significantly minimize water runoff.	The experimental work can carry error and must be validated.
(Li & Yeung, 2014)	Biodiversity Pollution Cooling Water Run-off	None	Literature	The capacity to withstand drought, increase albedo, and be native or not native are three prominent factors used to pick plants for green roofs.	The methodology needs to be extended beyond literature.
(Yang et al., 2008)	Air pollution	None	Mathematical model	19.8 ha of roofs with vegetation eliminated 1675 kg of air pollutants in total in a year, with O ₃ making up 52% of that amount, NO ₂ making up 27%, PM10 making up 14%, and SO ₂ making up 7%.	

2.1.2. Previous theses

For the purpose of surveying the previous theses that studied the subject, several that were conducted in the subject region of this study have been reviewed and the following ideas have been explored:

(Mankuri) Designed a built-in green roof and façade for existing building with native plants to the area but the study has more to do with the aesthetic of the building. Although there were several benefits investigated by the researcher, it lacks the important aspect of evaluating the impact of the green systems on the existing building performance. (SABAMEHR, 2019) tested the green systems on urban level in Istanbul and successfully showed a decrease in temperature and CO₂ level after applying the green roof to simulation. The study showed a small change, but it would have showed more if the system had been applied at urban level (multiple buildings) rather than only one building. (Tbayshat) was evaluating the opportunities and threats of introducing green roof and façade to Amman city. The initial cost and the water needs are primary concerns while the chance for long term investment and saving resources are primary benefits for the city. Using green roof with insulation was the conclusion set by (Tbayshat) where the author tested three green roof scenarios and recommended not to apply green roof without insulation because it has very little effect on the building U value. Yet green roofs with 100-150 mm insulation showed up to 6 % savings in heating consumption. The review of theses shows that there are not many studies conducted in our region on green systems specially for retrofitting purposes.

2.2. Green modular systems

Scientific research is moving toward the creation of innovative technology solutions to lessen the impact of buildings on energy use and the environment, as humans are concerned about climate change and the depletion of fossil fuel supplies. Consequently, in recent years, Important ideas like energy conservation and environmental sustainability have an impact on the design of both the construction of new buildings and the renovation of old ones. The reaction to these issues must be studied

carefully because the method of solution is as important as the solution itself. According to (one nine elms, 2022), 100 million structures are thought to exist worldwide. Building construction has increased significantly in recent years, and this trend is anticipated to continue. According to UN estimates, there will be 9.7 billion people on the earth by 2050, necessitating a rise in the number of structures. By 2050, there will be 2.6 billion structures worldwide, with 1.6 billion of those being new construction. The already existing 100 million building in the world are certainly not all green, nearly only 120,000 of them are green-rated buildings. (Ormond, 2020) The existing changes in climate, the pollution and the depletion of resources is already overwhelming so there must be a way to fix the existing structure rather than demolish and rebuild from scratch. Retrofitting the buildings, we have to relieve the pressure on the environment is the sensible method of going forward while restricting the green codes on new buildings. Nowadays it is unlikely to find much greenery in our urban environment which contribute to the high temperature and thus the high consumption of energy. The filtration quality of greenery is certainly needed for healthier environment. The modular green system is a valid retrofitting system because it can be installed without disturbing the structure and will provide a more sustainable living style.

There would have been a significant potential for the building's energy efficiency if the green roofs ability to lower cooling and heating requirements had been identified and had been included in the initial design.

Because climbing plants cling to exterior walls using adventitious roots or self-adhesive pads, direct green façades, also known as "traditional green façades," do not need structural support (Coma et al., 2017) (Pérez et al., 2011). However, with the help of supporting structures like stainless steel cables, modular trellises, or stainless-steel mesh, double-skin green façades, often referred to as indirect green façades, allow climbing plants to build a second skin layer distant from the wall and grow upward (Feng & Hewage, 2014). Vertically mounted modules, pre-planted blankets, and pre-vegetated panels are also used to create green walls. This allows plants to grow without needing a place to root at ground level. An investigation of all pollutants produced during the installation of living walls shows that the felt layer system pollutes the environment three times more than the modular panel system and trellis system. The felt layer system may also need up to 23 years to balance the pollutants (emissions). Since a felt layer living wall has an anticipated lifespan of only around 10 years, the pollution removal benefit of the system cannot offset the pollution it initially produced (Ottelé et al., 2011). Trellis

systems and modular panel systems might easily balance air pollution and purification given their 50-year life expectancy. The classification of vertical green system is summarized in Figure 6.

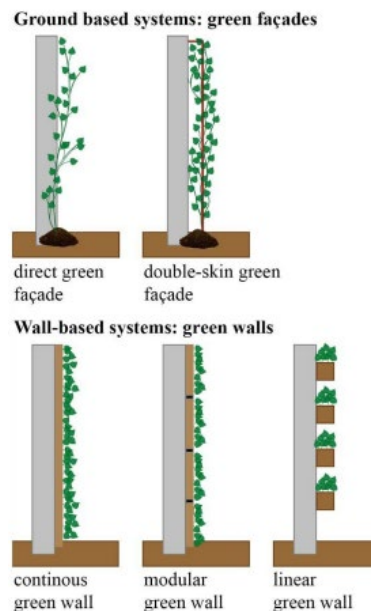

Figure 6. Classification of vertical greening systems. (Ottelé et al., 2011)

(Korol & Shushunova, 2018) The predominant use of green plantings as building and structure covers helps to create new urban space, enhances the environment, and lowers greenhouse gas emissions into the atmosphere. The rise in the degree of environmental safety in the city is characterized by a total decrease of 52.3 million tons CO₂ in greenhouse gas emissions by 2020. The most effective solution is to build roof coverings with landscaping systems using modern modular technologies, as this reduces Compared to conventional forms of roofs, technological methods during roof construction need less manpower and allow for functional growth for roof exploitation. According to the observations and measurements by (Lin et al., 2013), the maximum cooling efficacy was up to 22.5 °C in the summer in Taipei, Taiwan, and 25.1 °C in the summer in Chiayi, Taiwan, in contrast to the findings of the observations in Singapore and India. The reason for this variance in cooling effectiveness is due to the various climates, green roof designs, building materials, etc. However, it was once again demonstrated that the green roof does have a significant cooling efficiency in a variety of

different locations. Fortunately, there is a way to get these benefits by retrofitting existing buildings with green system modules. The incorporation of module system requires none to minimum disturbing of the existing structures making it a solid option to retrofitting existing building sustainably into more sustainable buildings. The process of making modular green system is a more sustainable approach than conventional green systems because it is prefabricated meaning less construction pollution, energy, and labor.

Modular green roof system shown in Figure 7 (Hejl et al., 2020) is a contemporary adaptation of the conventional layer concept for vegetal or green roofs. When building the roof, we innovated by integrating ready-made flora in modules that were made for easy installation. Additionally, certain modules are "greened" before being installed. The green roof's modular design makes maintenance and repair simple by allowing for the removal of individual modules and their replacement with fresh ones. Since new technologies have been developed to create green roofs over the past years, we have also seen current systems of discrete elements used in layers of green roofs develop. These systems are continuously being merged into new modular systems.



Figure 7. Modular system visualization. (Hejl et al., 2020)

The results indicated by (Korol & Shushunova, 2016) that environmental benefits and significant advantages of modular green roof systems over roll-out green roofs make them an energy- and future-proof solution for green buildings. Modular green roofs benefit technology, the environment, and human health while advancing a variety of sustainable goals in connection with sustainable practices.

(Korol & Shushunova, 2017) stated that the core of these modular green roofs lies in the specific cells — modular trays with plants connected to the gratings by attachments — that are placed over the surface of the building top. Modular trays are equipped with irrigation and drip irrigation systems to create a microclimate zone directly above the building's roof. While the green roof covering modular device must be monitored and managed during installation. The physical experiment done by (Loiola et al., 2019) in Brazil proved the tray modules illustrated in Figure 8 even after being used for more than a year, to be heat-resistant and to be free of wear or cracks. The green roof tray system was incredibly simple to install and maintain. Despite being subjected to the extremely hot and dry conditions, plants grew nicely. The authors suggest the increased use of modular-green roof systems to help with flood management, especially in highly populated metropolitan areas. They demonstrated how these systems significantly reduce hydrograph peak flows, which, when paired with hydrograph abatement supported by rainfall retention in the modular-green roof system, would significantly aid in flood management.

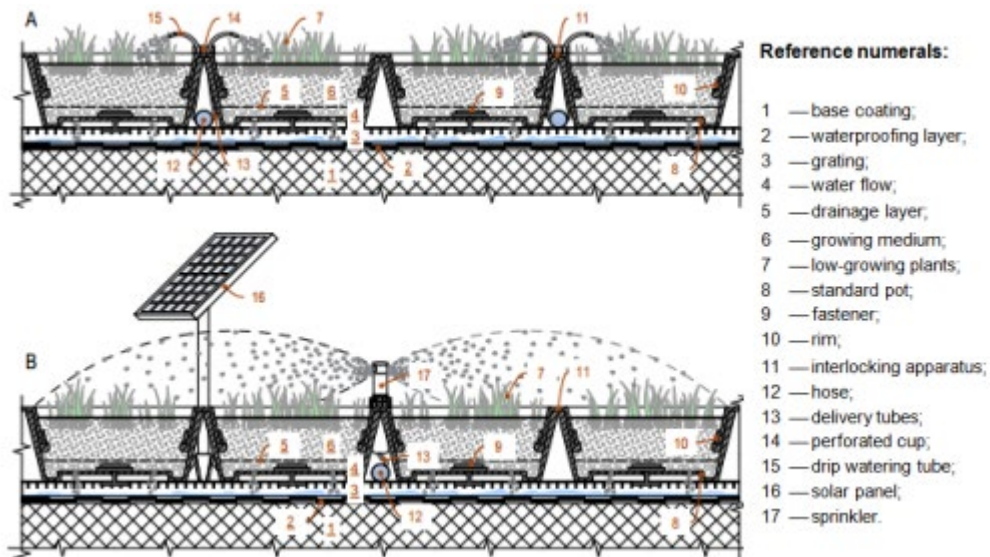

Figure 8. Schematic section of modular green roof system. (Loiola et al., 2019)

According to (Kamel & Memari, 2022) With the extra benefit of utilizing building science principles and knowledge, many innovative items are employed in modular retrofit systems, solutions for retrofit construction, such as including moisture

management measures in the wall system prior to installation. Because the overall cost of a refit, as one would assume, depends on the materials, precast pieces can also save on installation expenses. And (Santi et al., 2020) supports the benefits of modular green systems where The substantial scientific literature on building exterior greenery systems highlights its advantages from acoustics and energy savings to environmental and psychological advantages.

A very important study done by (Baiceanu & Catalina, 2019) showed the average energy savings by installing a big green roof onto an energy-efficient structure is 1.01 % for heating and 4.61 % for cooling; however, by modifying a few variables (such as low LAI in winter and high LAI and plant height in summer), energy savings may reach 1.55 % for heating and 5.95 % for cooling. For the purpose of retrofitting an existing structure, various building envelope options were assessed for their energy behavior. The results obtained by (Cascone et al., 2018) In comparison to the conventional envelope, creepers with thick leaf covers demonstrated a 1.5 °C reduction in interior surface temperature and a 1.7 °C decrease in air temperature. In addition, the temperature at the surface of the ground dropped by 2.9 °C. Finally, a 32 % reduction in thermal consumption is achieved. These findings demonstrate the energy required for summer air conditioning has been greatly decreased by shading the wall. An intense approach toward the methodology of creating such system is achieved by (Perini, 2013) by the use of a design tool (process tree) for horizontal and vertical greened surfaces allowed for the assessment of vegetation's ability to retrofit as well as the relationship between climate characteristics and the efficiency problems that were encountered with the choice of plant species, systems, and technology that were more suitable for the specific situation (of which the environmental and economic impact are also evaluated). An analysis by (Korol & Shushunova, 2016) showed For the least time-consuming and arduous installation, green roof modules should have the ideal physical specifications. The approach that provides method for covering roofs with rounded shape modules is a green roof system that can be installed in a reasonable period of time and is distinguished by the least laboriousness. For every 1,000 square feet, the installation of a green roof made of 400 × 500 × 100 mm modules needs 3.8 person-hours. The research's conclusions showed that the following physical characteristics of green roof modules are optimal for offering the quickest installation: Saturated mass of 60 kg/m², recycled high-density polyethylene (HDPE) as the module's material, typical dimensions of 400 × 500 × 100 mm (D1x D2x H), and sedum and herbs as the vegetation. (Santamouris et al., 2007)

The following materials make up the green roof system, from the outside in: Plants
Based on factors like:

- a) length of flowering
- b) location circumstances
- c) water and care requirements

The nutritional value and light weight of the soil substrate mixtures were taken into consideration. Irrigation system was placed to distribute water efficiently. Hydroponic stone wool was chosen for its lightness and storage capacity. Geotextile was used as a drainage layer and waterproofing membrane. Vegetation was utilized on the upper layer of the module. Cleaning, inspecting the waterproof membrane, installing the modules, and filling in the spaces with beautiful gravel are the four simple processes required to complete the installation of a modular green roof. The technology is more versatile than conventional green roofs and green walls since it may be used to generate either green walls or green roofs, or both. Its selection of components is based on the recycling of mine waste to produce alkaline activated binders (geopolymers), which integrate local resources (such expanded cork) with indigenous plants that can withstand the arid Mediterranean climate. The modules are made up of an upper Expanded Cork Board (ICB) plate and a geopolymer base plate. These materials prevent excessive thermal gains, restrict heat loss through the envelope in the winter and shield it from direct solar radiation in the summer. (Hejl et al., 2020) (Medl et al., 2017) (Manso & Castro-Gomes, 2016)

Essentially, modular design seeks to break a system into readily interchangeable tiny, standard elements. Modular designs are frequently self-contained pre-planted blocks for green roof systems, providing an immediate greening impact and more design freedom. but they mostly consist of the main layers shown in Table 2. (Hui & Chan, 2008)

Table 2. Main layers of green roof. (Hui & Chan, 2008)

Element	Details
Vegetation Layer	The green roof's plant layer gives nature and life a place to call home that is perfectly adapted to their need. The method below is created in line with the many planting alternatives that may be used on green roofs to ensure successful coverage. We provide a variety of vegetation layers,

(cont. on next page)

Table 2. (cont.).

Element	Details
	from fully developed blankets (of grasses or wildflowers) that spread out like turf, to plug plants, seeds, and more.
Filter layer	The filter layers in a green roof system are crucial. They keep the nutrients and particles inside the system and prevent rain from washing them away. The polymer used to create the filter layers is sturdy enough to defend against the elements while also being malleable enough to fit into any design.
Growing Media	A green roof's growth medium are an essential element. Fundamentally, it must have low nutrient levels to keep the plants simple to manage, hold a specific amount of water while being free draining to prevent root rot, and have a granular texture to preserve the roots' crucial aeration (which is essential for plant health).

2.3 Implementation

Designing and constructing an eco-friendly system has a considerable upfront cost. Owner should expect to pay between \$8 and \$40 per square foot for an eco-roofing system, including insulation. Green roofs with custom designs are always more expensive than prefabricated ones (MGS). A green roof must support all of the plants and culture in order for the user to get its benefits. A green roof loses its usefulness if all of the plants perish. Even with modest plants, gardening and landscaping expenses must be considered.

Sadly, leaks and damage are possible with felt layer green roofing systems. The waterproof membrane may become penetrated by plant roots, causing roof leaks that may cause structural damage. (Curry, 2019) In addition, there is limited plant selection for the greenery must be low maintenance and native, some scattered uncontrolled plant growth can happen. Another concern is for felt layer roof is root development into the structure and the limited space to do so plus the weight consumption the system has upon the structure, but this issue does not concern modular green systems. (Hussien et al., 2023; Manso & Castro-Gomes, 2015). Green systems offer a variety of advantages along with various disadvantages (Figure 9).

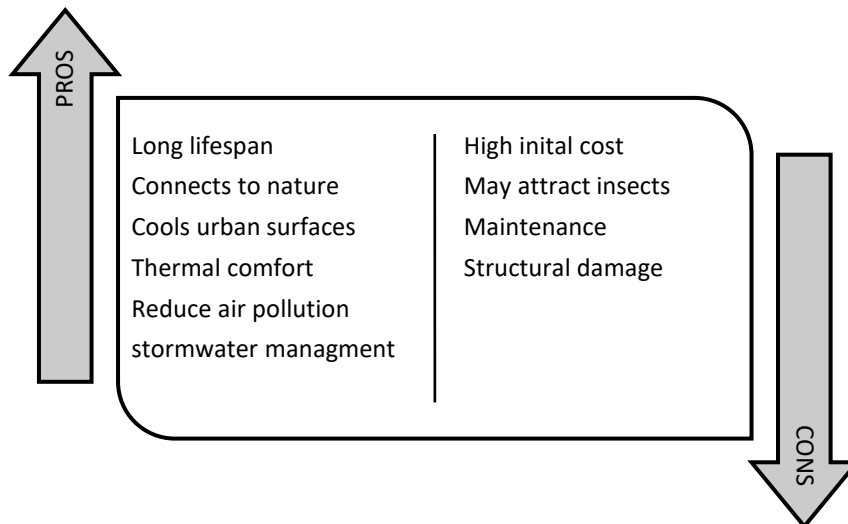

Figure 9. Green system's pros vs cons.

2.4. Softwares

An important part of this study is the assessment Softwares that will help answer the questions of this work. In this section two Softwares will be introduced and their role in similar studies will be explored as follows:

2.4.1. DesignBuilder/EnergyPlus

EnergyPlus, a new building performance modeling program, combines the best features and capabilities from BLAST and DOE-2 with extra capabilities. Fortran 90-written new code may be found in EnergyPlus. There is no official user interface because it is basically a simulation engine. Numerous user interfaces created by independent third-party developers are included in both DOE-2 and BLAST. Numerous cutting-edge simulation capabilities are present in EnergyPlus, including user-configurable modular systems, variable timesteps, and zone simulations based on heat and mass balances. The construction of third-party modules and interfaces is made easier by the customization of input and output data structures. (Crawley et al., 2000) (Crawley et al., 2001) The

interface used in this thesis is Design Builder software, which is capable of analyzing the basic project information and the various building types, developing different technical route strategies, and project location. It also offers a rich selection of products that designers can use to effectively analyze the built environment, as well as a unified data model that allows for the completion of computational analyses of energy conservation and building simulation. (Zhang, 2014) Design builder has valuable features mentioned by (Pawar & Kanade, 2018) for instance, easy-to-use Building models may be put together using the Open GL solid modeler by placing, extending, and cutting 'blocks' in three dimensions. Realistic 3-D elements have no restrictions on geometric form or surface shape, and they give visual input of actual element thickness, room areas, and volume. Other features include the capability to import 3-D CAD models from BIM applications implementing the gbXML standard, such as ArchiCAD, MicroStation, Revit, etc. The user may choose from drop-down menus in data templates to import popular building constructions, activities, HVAC, and lighting systems into the design. The accuracy of DesignBuilder thermal simulation results, in comparison with the experimental data is the main question of (Eisabegloo et al., 2016) However, there are certain issues when using this program for thermal modeling of historic structures in hot and arid areas. The simulation results might provide a decent estimate of internal thermal conditions for the majority of rooms. The software's inability to determine the impact of evaporative cooling is its most significant shortcoming. The authors of (Wasilowski & Reinhart, 2009) found that While employing customized internal consumption schedules as opposed to default ones decreased the relative inaccuracy of anticipated vs metered yearly power usage from 18 % to 0.2 %, the advantage of using customized weather data in design builder as compared to a local TMY3 file turned out to be modest. Heating and cooling consumption was obtained by (Blanco et al., 2016) using the software taking into account additional variables such as the airgap and location demonstrating the suitability of the previously optimized configurations in terms of relative energy savings.

The bulk of such research looked at the energy savings possible using EnergyPlus and DesignBuilder, which functions as the EnergyPlus simulation engine's user interface. EnergyPlus uses the FASST soil and vegetation models to construct the EcoRoof concept. (Frankenstein & Koenig, 2004), which allows simulating the presence of a green roof by adjusting a few plant and soil characteristics, as well as directly coupling the green roof energy balance equations to those of the building. Similar to this work DesignBuilder software was used to examine how vegetation, and more specifically the LAI parameter,

affected the energy efficiency of a modest office space in Palermo. in '(Ferrante et al., 2016) The study emphasized how, in the Mediterranean environment, green roofs are more essential in the summer, with a noticeable reduction in cooling demand.

When comparing the energy usage of green, conventional, and cool roofs while taking into account a single-floor office building (Zeng et al., 2017), thicker soil was discovered to contribute to larger energy savings. However, increasing the thickness too much resulted in less obvious savings and a higher starting cost. Different green roof typologies were explored in a Portuguese case study building to estimate the achievable energy savings including extensive, semi-intensive and intensive roofs. (Berardi, 2016; Silva et al., 2016) (Karachaliou et al., 2016)

Overall, EnergyPlus tool within DesignBuilder has proven in many studies that it has the ability to calculate the impact of different types of green systems for various levels, buildings, goals, and parameters. The flexibility of the software is illustrated in its ability to assess many parameters and types of green systems depending on the variables each study.

2.4.2. Granta CES EduPack

A distinctive collection of instructional tools, Granta EduPack—previously CES EduPack—supports the use of educational materials. Granta EduPack provides support to enhance the teaching of undergraduate course content. EduPack comes with a database of information on materials and procedures, tools for choosing goods, and a number of supplemental resources. (Ansys, 2023) It provides a simple-to-use Eco Audit Tool that enables students to investigate a product's environmental effect over the course of its existence. Cost models that reveal some of the economic factors are also included. (Ashby et al., 2021) This software has wide usages in many fields, it is a great tool to assess the value of products in all industries, this allows for a pre application overview and exposure of potential pros and cons in the short and long run. (Hamade et al., 2020) was using CES EduPack to conduct a preliminary life cycle analysis to determine the relative effects of transport and use in comparison with material and manufacture of the 500 mL PET (Material PET unfilled, semicrystalline) bottle. While (Hamade et al., 2020)

conducted Life Cycle Analysis (LCA) of AA alkaline batteries takes into account alternatives to waste, such as downcycling or, more avowedly, recycling/remanufacturing. A free online program called GRANTA Edupack calculates the carbon emissions of composite goods. (Jena & Kaewunruen, 2021) employed it in accordance with the makeup and production methods of the FRP. The tool is designed specifically for composite materials and calls for precise data and information on the "recipe" of the material. The large GRANTA Edupack material database contains details and characteristics of a wide range of materials.

Life cycle analysis is crucial for determining the optimum options for choosing materials and manufacturing techniques for a given product. When discussing sustainability, the LCA is crucial because it offers a potent instrument to assist the project when faced with consumer activity and an increasingly short anticipated useful life of the product. It also gives a strong tool to reflect on the selection of materials and procedures suited to each project. That is why (Marques, 2013) used Edupack software to assess the potential negative impacts of design on the environment. An example of pre-construction analysis was produced by (Dabous et al., 2017) using A database of more than 4000 distinct materials and more than 200 manufacturing processes were incorporated in the EduPack 2016 program. The case study's analysis revealed that the material phase has a major influence on the life cycle. The study found that replacing the deck has a greater life cycle cost and environmental effect than simply maintaining and reinforcing the deck. which can help in decision making of implementing huge projects like bridge construction. A successful analysis conducted by (Luna-Tintos et al., 2020) employing the technique of the Eco Audit tool from CES Edupack. Conclusions concerning the optimization of a structural system with lower environmental demand and the potential for applying information from this competition to creative systems of new dwelling types were reached via this investigation. (Pollini & Rognoli, 2021) listed the software as a good method to conduct simplified life cycle analysis specially in early stage where the decisions are crucial and have a huge impact on the path of the project.

2.5. Practical review

Several local buildings were found to have a green system. The Zorlu Center in Istanbul features a 72,000 m² roof garden with a layered green system, incorporating nature and tranquil spaces. The project's shape, facade, and structure were created using experimental techniques influenced by the surrounding environment. The natural stone facades give the buildings a soft exterior. Atlantis Aurora installed a green wall at the Erasta Shopping Centre in Fethiye. The Atlantis Aurora green wall team's implementation methods replicate natural circumstances and can be adjusted to different geometries. The vertical walls with planting modules is used in Sentido. These modules can be chopped vertically and horizontally to match neighboring facades, allowing the planting system to better satisfy architectural specifications. The modular design allows for easy removal and reinstallation. The Greenox building, with 900 trees covering its façade, is said to result in reduced utility costs and a smaller carbon impact. Compared to a typical apartment building, the structure can save up to 35 % energy, 42 % water, and 41 % embodied energy in materials. (Braun, 2015) (Archello, 2010) (ODS, 2022) (ELİNÇ et al., 2013) (Samu, 2016). All the mentioned cases are summarized in Figure 10 and 11 and Table 3.



Figure 10. Local buildings with green system. (Braun, 2015) (Archello, 2010) (ODS, 2022) (ELİNÇ et al., 2013) (Samu, 2016)

The Musee du quai branly complex, the Orto fra i cortili, Chongqing Taoyuanju and the Roofpark Vierhavenstrip are examples of international buildings with green systems. The Musee du quai branly complex features a 200 m long and 12 m high living wall, which allows a wide range of flora to thrive in the microclimate created by the River Seine's frontage, park, and side streets. The Orto fra i cortili is the largest green façade in Australia, covering all façades from level 2 to level 33, with around 7 square kilometers of vegetation encircling both towers. Urban greening and climate adaptation pose challenges for architects and designers of the built environment. One Central Park serves as a model for future urban projects that employ urban greening techniques to create more sociably and environmentally sustainable communities. Orto fra i cortili is a rescued roof transformed into a green roof for residential use, featuring four different plant varieties and a shielding effect to lower the building's temperature. The Roofpark Vierhavenstrip project offers benefits for the neighborhood and the larger district, with tall trees and thick hedges on the eastern side and theme gardens on the western half. The Chongqing Taoyuanju's green roof and walls integrate the structure with its surroundings and improve the thermal performance of the building envelope. The project separates off two courtyards: a green plaza for community events and a sloping garden. (Velazquez, 2014) (urbanNext, 2023) (Land8, 2016) (Land8, 2016) (ArchDaily, 2015)



Figure 11. International buildings with green system. (Velazquez, 2014) (urbanNext, 2023) (Land8, 2016) (Land8, 2016) (ArchDaily, 2015)

Table 3. Buildings in & outside Türkiye with green systems.

Case	Location	Building type	Green system	Plant type	Climate
Local					
Zorlu center 2008	Istanbul	Mixed-use	Built in roof and façade	Perennials Shrubs Trees	Temperate
One & Ortakoy 2022	Istanbul	Mixed use	Built in roof	Grass Shrubs Trees	Temperate
Erasta Shopping Mall 2022	Antalya	Retail	Module façade	Sedums	Mediterranean
SENTIDO Zeynep Resort Hotel 2009	Antalya	Residential	Module façade	Sedums	Mediterranean
Greenox 2018	Istanbul	Residential	Built in roof	Grass Sedums	Temperate
Global					
MUSEE DU QUAI BRANLY 2006	Paris, France	Museum	Built in hydroponic façade	Grass Herbs Flowers Shrubs	Continental
ORTO FRA I CORTILI 2006	Milan, Italy	Residency	Modular green roof	Medicinal Herbs Flowers	Temperate
Chongqing Taoyuanju 2015	China	Community Center	Built in green roof	Grass Shrubs	Humid subtropical
Roofpark Vierhavenstrip 2018	Rotterdam, Netherlands.	Retail	Built-in green roof	Trees Grass Bushes	Temperate oceanic
One Central Park 2014	Chippendale, Australia	Retail	Built in façade	Flowers	Tropical

CHAPTER 3

MATERIALS AND METHODS

The study applies the methods of comparative analysis of four alternatives of greening systems for retrofitting an existing building, based on the principles of their impact on building energy performance and the efficiency of their life cycle. First, several roof and façade alternatives for the system are explored in terms of multiple inputs such as leaf index area, size of module, materials, and the case study. These selections are based on the literature review, practical review, and company records. Secondly, the set of alternatives are evaluated from extraction to production using Edupack software that provides LCA database and analysis for comprehensive typology of products. Thirdly, the output of the 2nd step is the optimal alternative material with the best size and features. This alternative is then evaluated in terms of building's performance and associated energy savings. Finally, the last evaluation is on if there is a gap between the LCA and energy savings and determine which provide good savings with minimal environmental impact. The study design illustrated in Figure 12. shows the flow of the study processes.

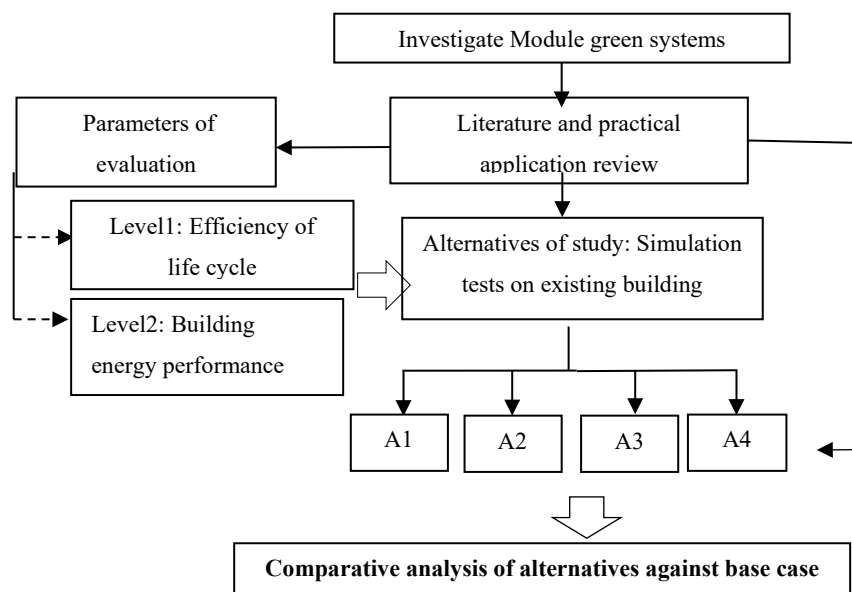

Figure 12. Thesis Methodology.

3.1. Case Building

The building is located in Türkiye, Izmir, Gülbahçe, Izmir Institute of Technology campus, belonging to Faculty of Architecture (Block-E) as shown in Figure 13. The floor plan has one central accessibility area in the middle consists of corridors, stairs, elevator, and some recreation areas (Figures 15, 16, and 17). The rooms serve mostly administrative purposes but there are few classrooms, meeting and utility rooms for the staff and students. 38.32° N, 26.63°E is the latitude and longitude coordinates of the building's location. The sun path is illustrated in Figure 14 , it rises at 06:16 and set at 18:26 with around 12 hours access to daylight.

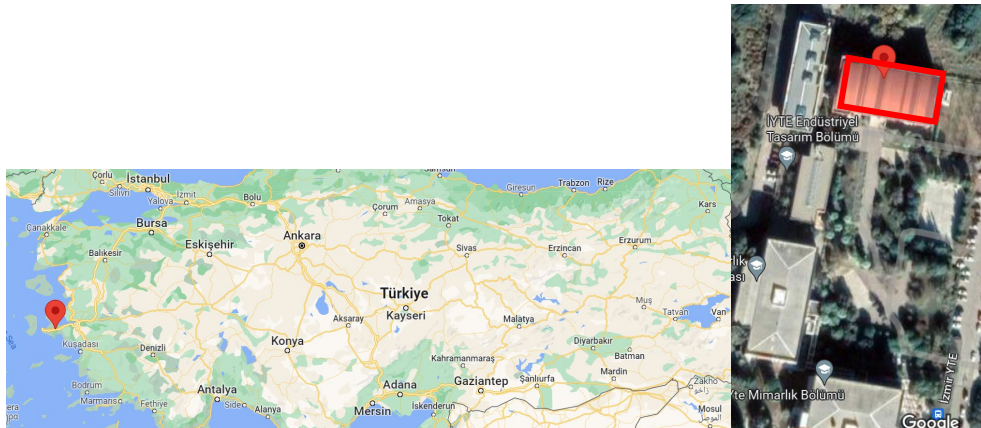

Figure 13. Location of the case study (Google maps)

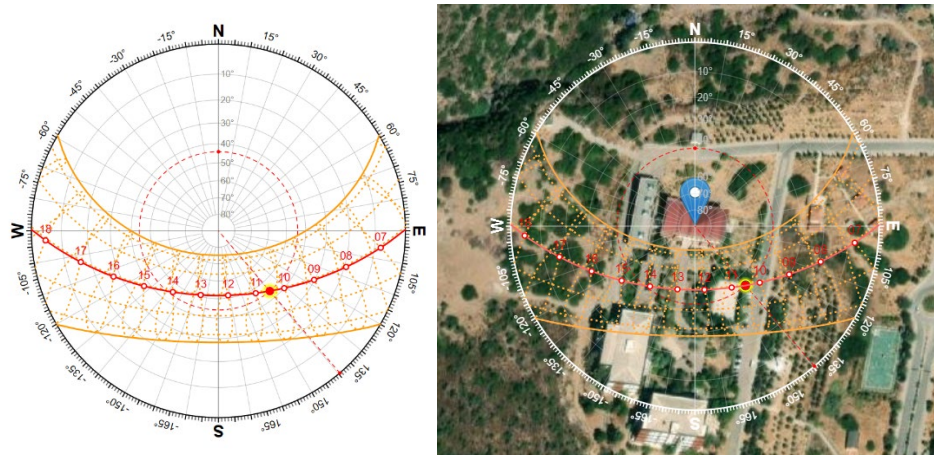

Figure 14. Sun path analysis of the case study.

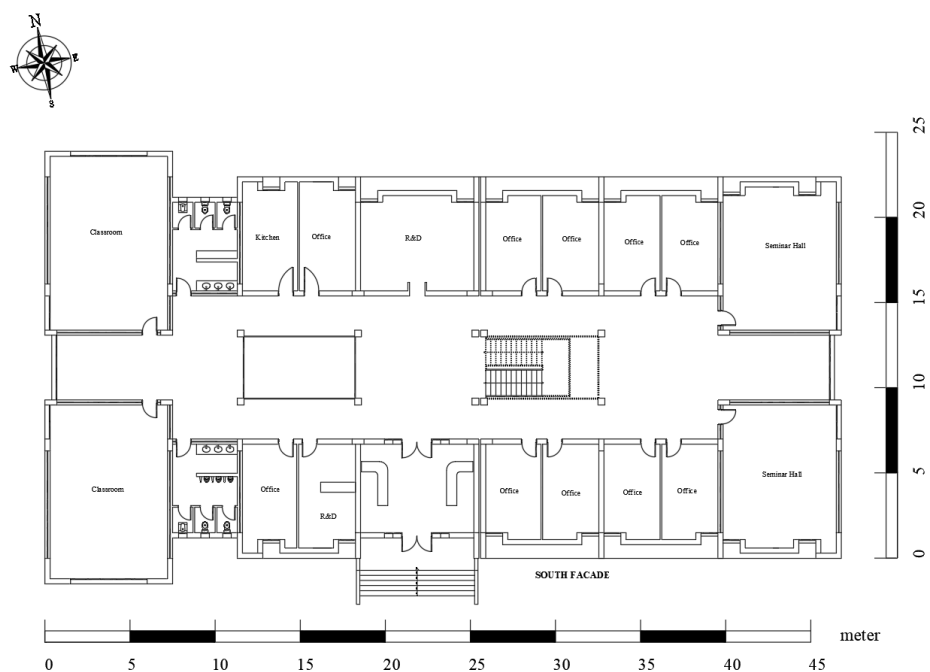

Figure 15. Case study building ground floor plan. (IYTE Directorate of construction and technical works)

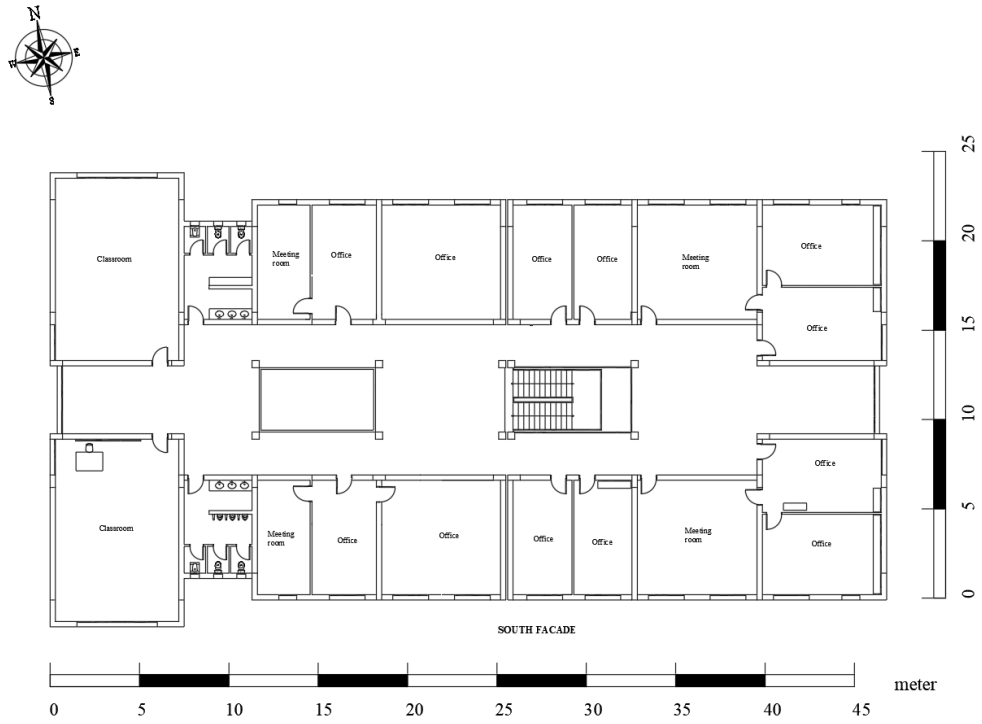

Figure 16. Case study building first floor plan. (IYTE Directorate of construction and technical works)

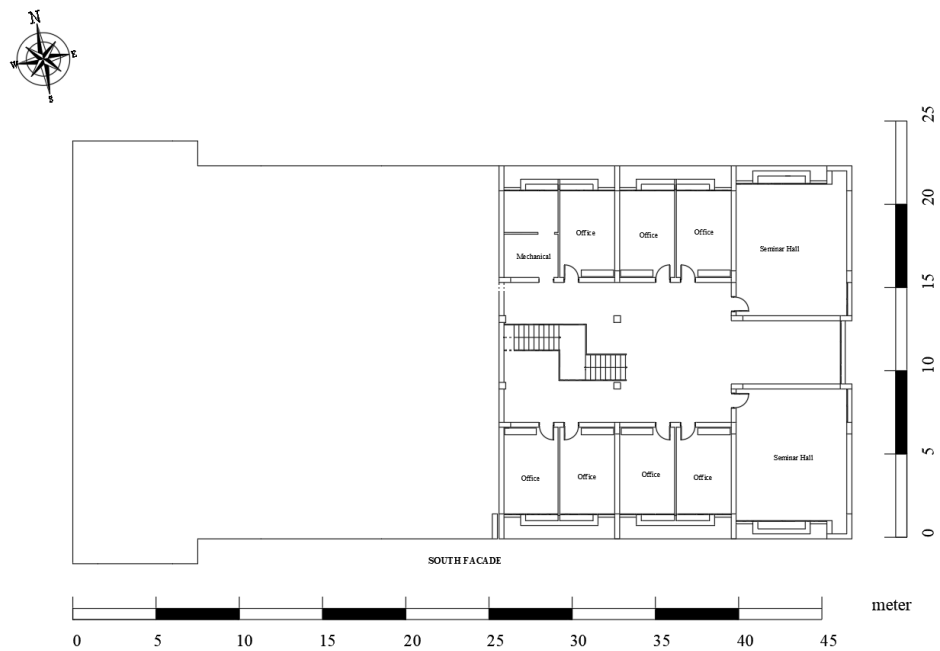

Figure 17. Case study building basement floor plan. (IYTE Directorate of construction and technical works)

Energy consumption data were provided by the university consisting of monthly usage for the case study building. The monthly consumption seems to fluctuate (Figure 18) and not to have a certain pattern, whereas the annual consumption declines from 32,000 kWh to 21,346 from 2019 to 2020 as shown in Table 5 and Figure 19, then starts an increasing trend probably due the effect of COVID19 pandemic.

The detailed construction of building's components is shown in Table 5, which were utilized in constructing the simulation model to give realistic results of the building performance. Nevertheless, the façade and roof exterior, details of which are shown in Figures 20 and 21 were the focus of this study.

Table 4. Case study building energy consumption data (kWh). (IYTE Directorate of construction and technical works)

Month	2019	2020	2021	2022
January	3,338	3,169	1,383	2,643
February	2,587	2,330	1,448	1,967
March	2,779	2,145	1,642	1,998
April	2,678	994	1,605	2,177
May	2,099	1,205	1,496	1,342
June	2,479	1,624	1,673	1,954
July	2,833	2,127	2,850	2,257
August	2,453	1,796	3,131	2,442
September	2,504	1,685	2,741	2,115
October	2,527	1,495	2,371	2,122
November	2,866	1,380	2,630	1,515
December	2,967	1,486	2,867	2,125
Annual	32,110	21,436	25,837	24,657

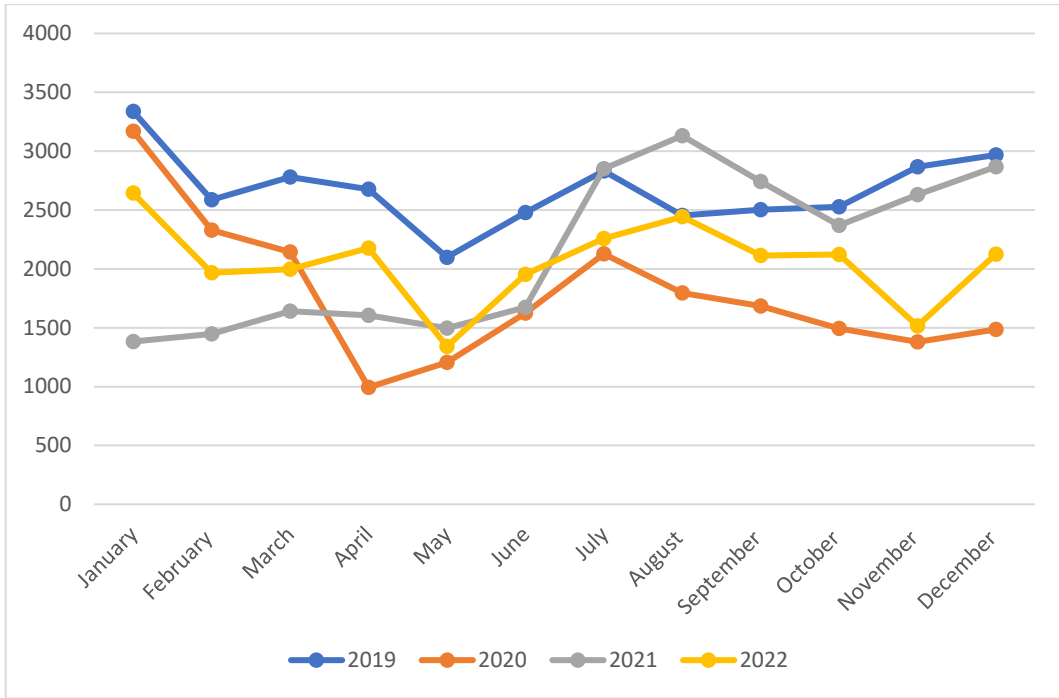

Figure 18. Monthly energy consumption (kWh).

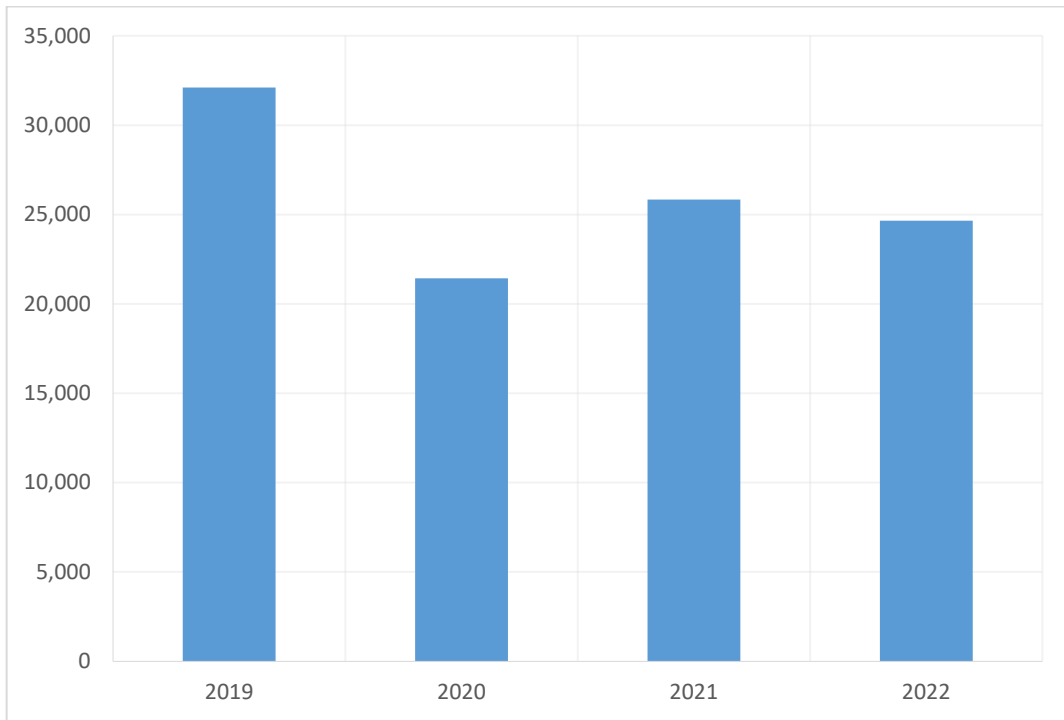
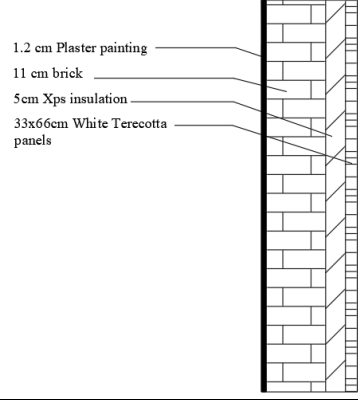
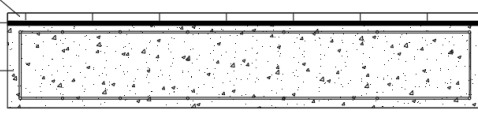
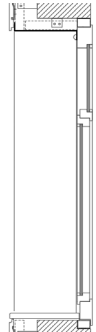

Figure 19. Annual energy consumption (kWh).

Table 5. Detailed construction of building's components. (IYTE Directorate of construction and technical works)

Element	Material (interior to exterior) Section
Wall	 <p>1.2 cm Plaster painting</p> <p>11 cm brick</p> <p>5 cm Xps insulation</p> <p>33x66cm White Terecotta panels</p>
Floor	 <p>1cm Marble</p> <p>0.5cm Mortar</p> <p>15cm reinforced concrete slab</p>
Window	<p>Double glaze</p> <p>Aluminum painted frame</p> 

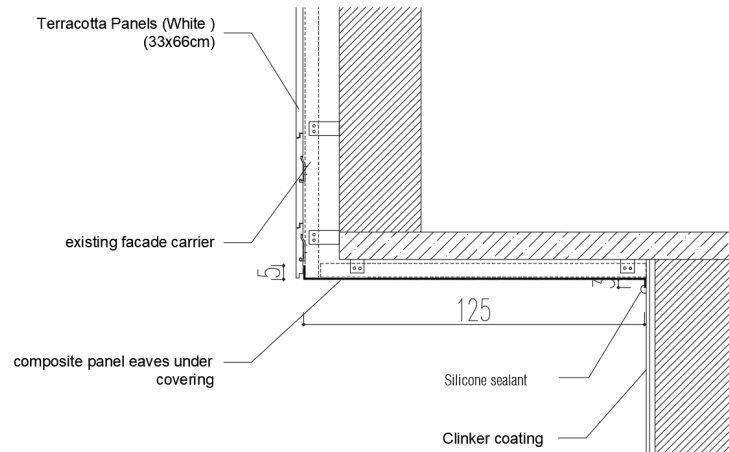

Figure 20. Section showing facade-slab connection. (IYTE Directorate of construction and technical works)

The long facades are facing south and north, they also represent the front and back of the building, respectively. The short facades are facing east and west, the east side is adjacent to unbuilt space while the west side is covered with a metal plate and adjacent to another building. The opening-wall ratio for North, South, East, and west facades are 22.5, 22.5, 16.6, 6.5 %, respectively.



Figure 21. Building facades.

3.2. Life cycle analysis

The life cycle analysis (LCA) is conducted via Granta Edupack. (Ansys, 2023) The operation of evaluating the MGS (Modular green system) started with a feature called eco audit where the product is defined, and the materials are chosen from the data base. The data for each material is essential to make decision of choice based on the purpose of the product provided in the download sheet in each material database. There is a manual input of each material to define the extraction, transportation, and installation methods. Then the analysis parameters shown in Figure 22 were run and the output that contains CO₂ and energy required, emitted, wasted for the product materials including extraction, manufacturing, transport, maintenance, and usage were obtained.

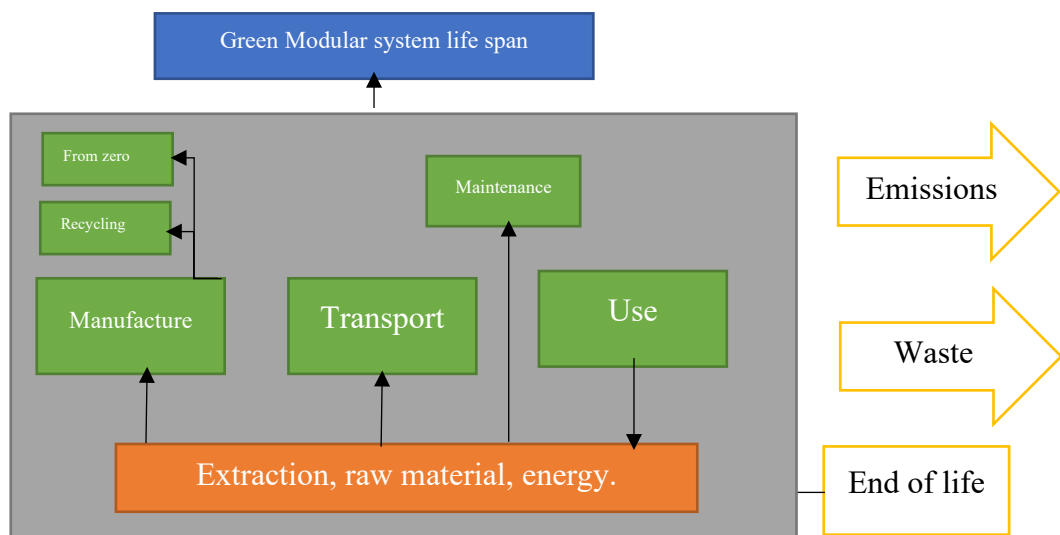

Figure 22. Level 1 method to evaluate the efficiency of the product over its lifespan.

3.3. Energy performance analysis

This study uses an existing building that is described in the next chapter in detail. The case is modelled in simulation software DesignBuilder as shown in Figure 23. The software requires physical and operational data of the building to predict primarily energy

and temperature of the case. The input includes plans, openings, activity, lighting, construction related information on the building. The output of the software will be compared with the measured data for the purpose of calibration and to predict with minimal error. Then, the inputs were adjusted accordingly and run again until satisfactory results were achieved. The goal is to be as accurate as possible to estimate how the system would affect the energy performance of the building.

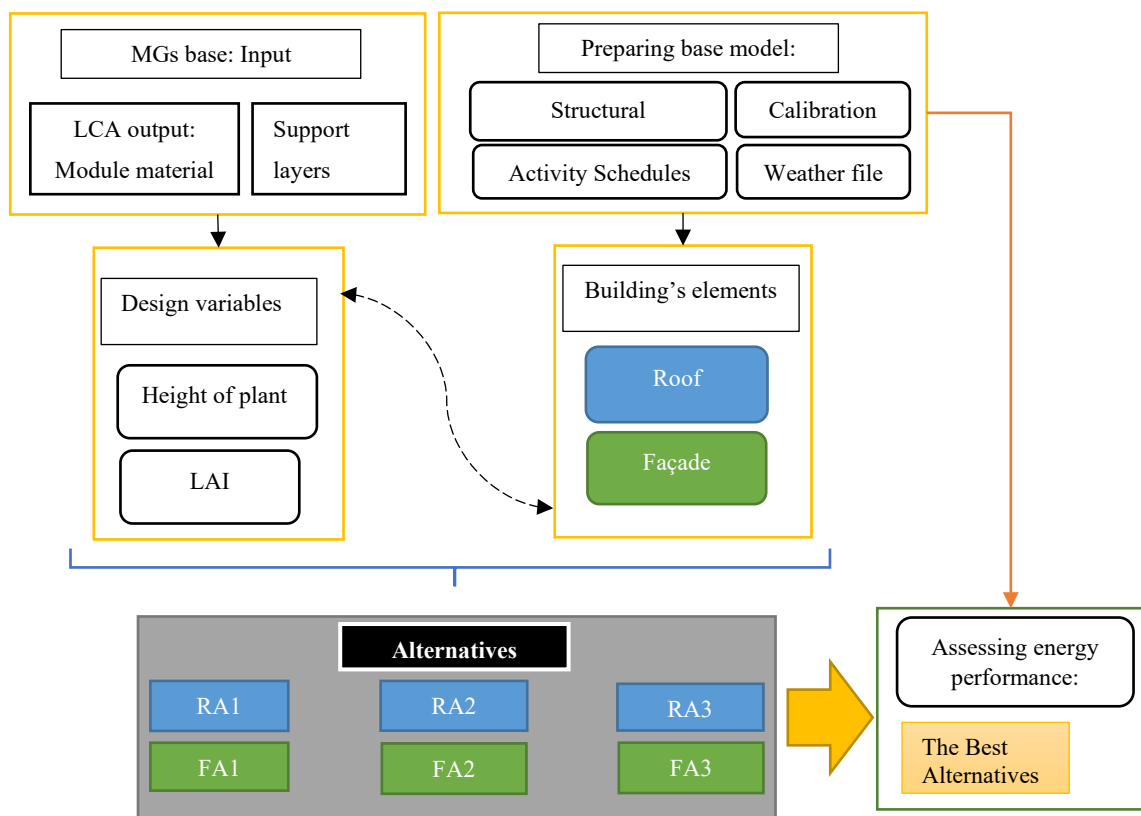

Figure 23. Methodology of energy simulation.

CHAPTER 4

ALTERNATIVES

The design of the modules is meant to be locally attuned and responsive, resource efficient and easy to integrate within the building. The plants chosen are researched extensively to make sure that they are native to the local area. The module size, shape and layers are chosen to the plant needs and to be simply inclusive to most building forms. Taking these factors into consideration different module materials, sizes and plant species were studied. The following sections illustrate the details of each alternative in terms of typology, materials, visualization, size, and operation. To expand, recycled plastic, cork, and fiberglass were considered for each alternative as tray material. Consideration of these materials was based on their strength to withstand weight and weather, sustainability, and local availability. The plant selection was based on the typology as the system gets denser the LAI increases then a native species is chosen accordingly. The LAI is the area of one green leave per square meter of ground; formulated as $LAI = [\text{Leaf area (m}^2\text{)}/\text{Ground cover (m}^2\text{)}]$. For evaluating the strength and growth of vegetation on the planet, it is crucial to track changes in LAI distribution. As a parameter in land-surface processes and parameterizations in climate models, it is fundamentally significant. (Gobron, 2005) Based on the intensity of the plant species the alternatives will have different depths from smaller (extensive) to bigger (intensive).

4.1. Roof Alternatives

There are three roof alternatives, representing a typology: extensive RA1, semi-intensive RA2, and intensive RA3, where RA stands for roof alternative. Each module size containing a certain type of plant, a native plant to Izmir, Türkiye has been chosen for each alternative. These modules will be installed on all the roof area (1048 m²) of the

building as shown in Figure 24 which will require about ± 1000 modules. There is a canopy-like structure on the roof that will be removed to install the green roof modules.

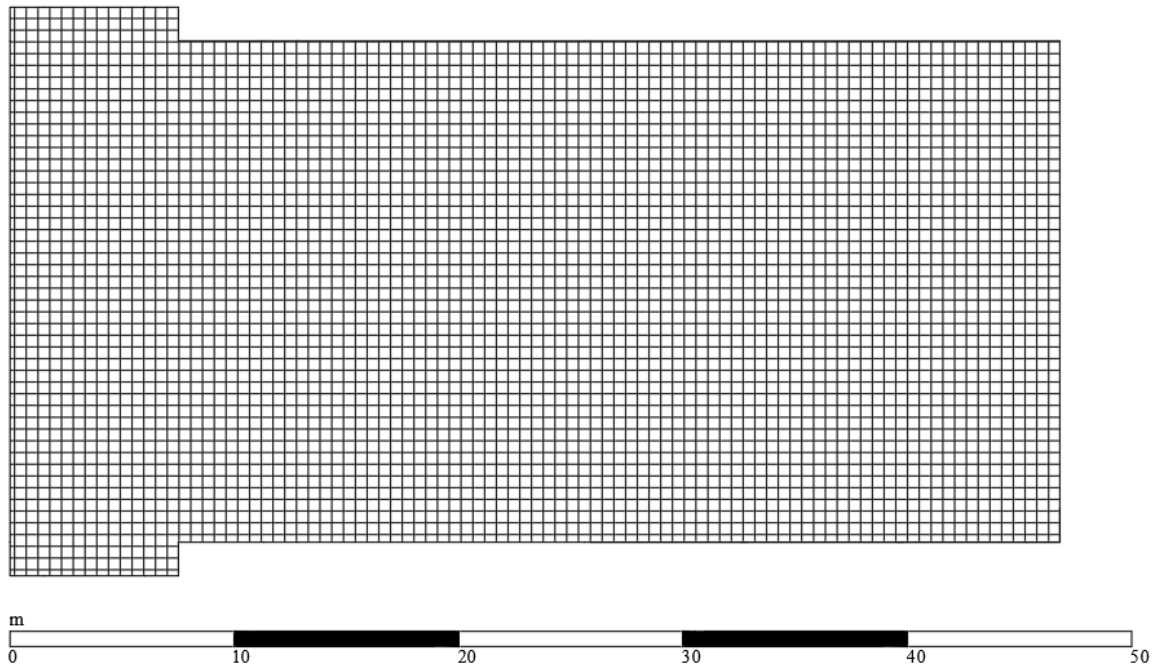

Figure 24. Schematic distribution of roof green modules on the building.

RA1 is sized to fit plants with maximum height of 10 cm such as grass (Gramineae) thus defining the growing medium thickness as 8 cm and the size of the whole module as 50x50x10 cm. RA2 is sized to fit plants with maximum height of 20 cm such as Arugula (*Eruca sativa*) thus defining the growing medium thickness as 12 cm and the size of the whole module as 50x50x20 cm. RA3 is sized to fit plants with maximum height of 45 cm such as *Lantana* (*Lantana camara*) thus defining the growing medium thickness as 20 cm and the size of the whole module as 50x50x30 cm. See Table 6 and Figures 25 for the details of each RA.

Table 6. Roof alternatives of the study. (DesignBuilder, 2023; YU, 2006)

Alternative	Plant Species	*LAI	Height of plant (cm)	Growing medium thickness (cm)	Filter layer (cm)	Module	System size (cm)
RA1	<u>Extensive:</u> E.g.: Grass	2.7	6-10	8	5	Recycled plastic	50x50x10
						Cork	
						Fiberglass	
RA2	<u>Semi intensive</u> E.g.: Arugula	3.5	15-20	12	5	Recycled plastic	50x50x20
						Cork	
						Fiberglass	
RA3	<u>Intensive</u> E.g.: Lantana	6.5	30-45	20	5	Recycled plastic	50x50x30
						Cork	
						Fiberglass	

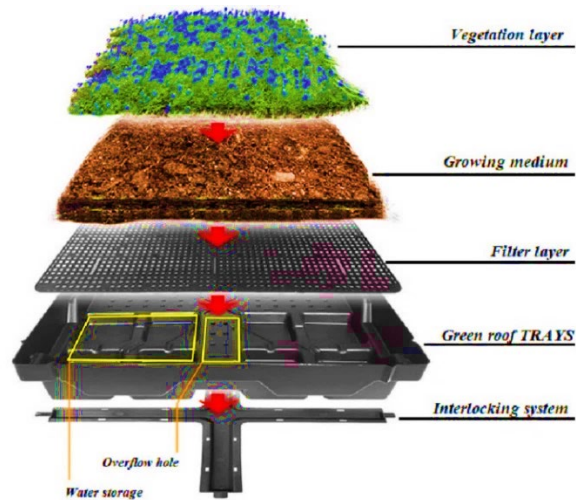

Figure 25. Modular roof system layers and components. (Sedum Green Roof, 2022)

4.2. Façade Alternatives

There will be three façade alternatives each representing a typology: extensive FA1, semi-intensive FA2, and intensive FA3, where FA stands for Façade Alternative.

Each module size containing a certain type of plant, a native plant to Izmir, Türkiye has been chosen for each alternative. These modules will be installed on West (185.2 m²), East (220.2 m²), North (278.2 m²) and South (276.2 m²) façades as shown in Figure 26 of the building which will require ±7000 modules. Some parts of the façade is covered with ceramic and brick tiles. The ceramic tiles will be removed to install the system while the brick part will be directly ready for installment.

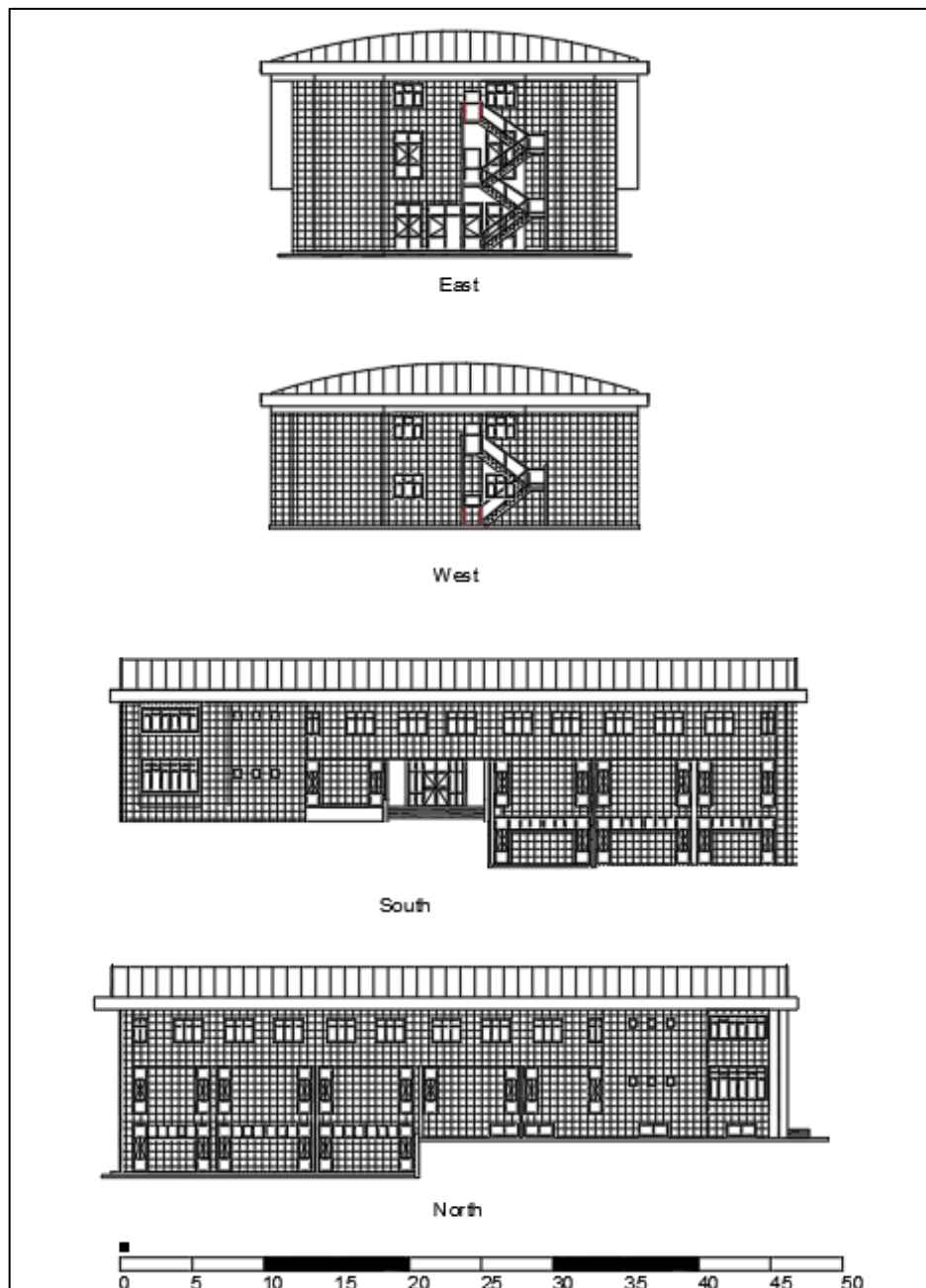

Figure 26. Schematic distribution of MGs for each facade on the building.

FA1 is sized to fit plants with maximum height of 10 cm such as *Serpyllum terminalis* thus defining the growing medium thickness as 8 cm and the size of the whole module as 30x30x10 cm. FA2 is sized to fit plants with maximum height of 20 cm such as *Pachysandra* thus defining the growing medium thickness as 12 cm and the size of the whole module as 30x30x20 cm. FA3 is sized to fit plants with maximum height of 45 cm such as *Heuchera* (*Heuchera sanguinea*) thus defining the growing medium thickness as 20 cm and the size of the whole module as 30x30x30 cm. See Table 7 and Figure 27 for the details of each RA.

Table 7. Facade alternatives of the study. (DesignBuilder, 2023; YU, 2006)

Alternative	Plant Species	*LAI	Height of plant (cm)	Growing medium thickness (cm)	Filter layer (cm)	Module	System size (cm)
FA1	<u>Extensive:</u> E.g.: <i>Serpyllum terminalis</i> .	2.7	6-10	8	5cm	Recycled plastic	30x30x10
						Cork	
						Fiberglass	
FA2	<u>Semi intensive</u> E.g.: <i>Pachysandra</i>	3.5	15-20	12	5	Recycled plastic	30x30x20
						Cork	
						Fiberglass	
FA3	<u>Intensive</u> E.g.: <i>Heuchera</i> .	6.5	30-45	20	5	Recycled plastic	30x30x30
						Cork	
						Fiberglass	

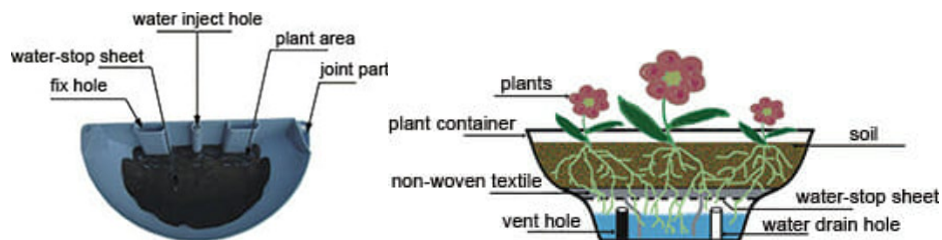

Figure 27. Modular facade system layers and components.(Greening Solution, 2023)

CHAPTER 5

LIFE CYCLE ASSESSMENT

The environmental impact of the modular green system is crucial to this thesis that is why all the alternatives were tested using Granta Edupack software on product level. The parameters in focus were the energy and CO₂ footprint of all the stages of each alternative, manufacturing, transport, and end of life. It is important for selection of the best material for the system before applying it to the building.

5.1. Input

The input is very specific, flexible, and customizable according to the category of the product undergoing testing. Each material used to construct the alternatives chosen in the previous chapter is studied to determine the processes that it undergoes to be molded and integrated for the final product. The author of this thesis has contacted several local companies in Türkiye to ensure the availability of the materials and the transportation type and distance required to obtain them. The goal was to have the optimum and realistic system that can be achieved locally and sustainably. All the data used in simulation are provided in Table 8.

Table 8. Details of data input in Granta Edupack LCA software.

Material	Manufacturer	Recycle content	Primary process	Secondary process	Transport		Life span	End of life	
					Type	Distance (km)		Reuse	Removed
Recycled Plastic	Esnekplastik	100%	Recycling	Molding	Truck	1286	100 years	100%	0%
Cork	Güvenal Lastik	0%	Cutting	Assembly	Truck	531	50- years	100%	0%
Fiber glass 1.5 kg/m ³	Fibropol Fiberglas & Aquaculture Solutions	0%	Cutting	Assembly	Truck	60	50- years	50%	50%
Normal Plastic	Plast Depo	0%	Cutting	Molding	Truck	75	25 years	100%	0%

5.2. Output

Materials were chosen in their basic form (Figure 28) to have the molding step into the size and form required to accommodate its function is included in the analysis. The consumption of energy and emissions of CO₂ are shown in this section for each material during all the lifespan of the material. Nevertheless, the usage impact is zero for all cases since the system is passive that requires no energy and emit no CO₂ to operate.



Figure 28. Raw materials of (A) Plastic, (B) Cork and (C) Fiberglass as alternatives for LCA (Granta Edupack)

5.2.1. Recycled Plastic

The recycled plastic has an impact during transport and disposal only (Table 10, Figures 29 and 30) because it is recycled and not manufactured from scratch. The energy required to manufacture, transport, and dispose are 16 MJ, 1.93 MJ and 0.2 MJ respectively making it a total of 18.1 MJ for every 1 Kg of recycled plastic. The CO₂ footprint of manufacture, transportation and disposal are 1.2 Kg, 0.139 Kg and 0.014 Kg respectively making it a total of 1.35 Kg for every 1 Kg of recycled plastic.

Table 9. Results of LCA for recycled plastic. (Granta Edupack)

Phase	Energy (MJ)	Energy (%)	CO ₂ footprint (kg)	CO ₂ footprint (%)
Material	0	0.0	0	0.0
Manufacture	16	88.3	1.2	88.7
Transport	1.93	10.6	0.139	10.3
Use	0	0.0	0	0.0
Disposal	0.2	1.1	0.014	1.0
Total (for first life)	18.1	100	1.35	100
End of life potential	0		0	

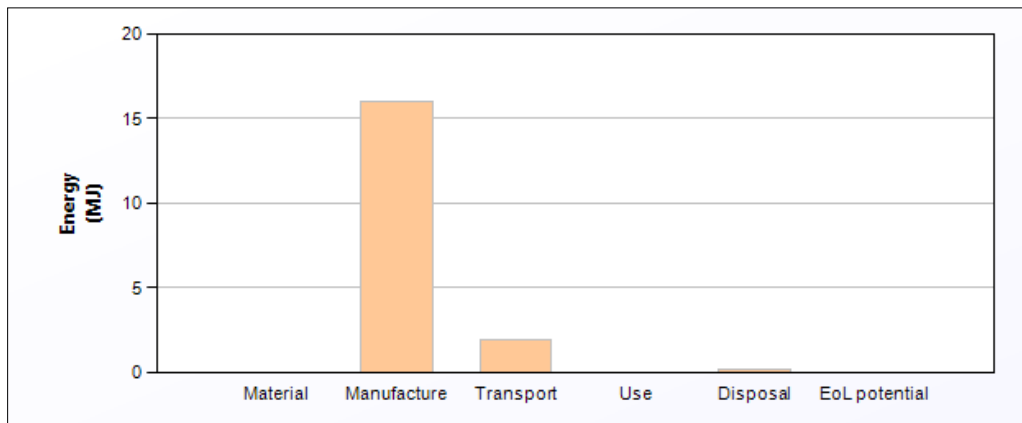

Figure 29. Energy consumption for recycled plastic. (Granta Edupack)

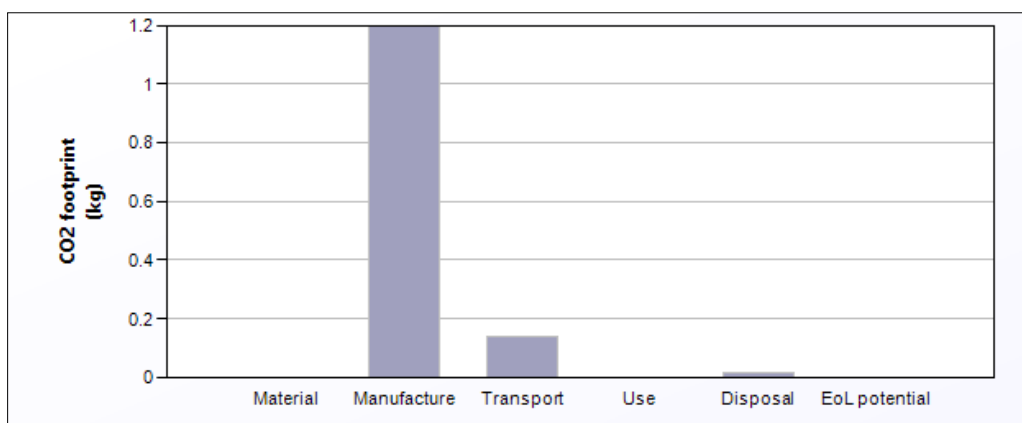

Figure 30. CO₂ emissions for recycled plastic. (Granta Edupack)

5.2.2. Cork

The cork has an impact during extraction, transport, and disposal only (Table 11, Figures 31 and 32) because it is a natural material that is not manufactured. The energy required to extract, manufacture, transport, and dispose are 52.1 MJ, 10 MJ, 0.797 MJ, and 0.2 MJ, respectively, making it a total of 63.1 MJ for every 1 Kg of cork. The CO₂ footprint of extraction, manufacture, transportation, and disposal are 1.76 Kg, 0.75 Kg, 0.0573 Kg, and 0.014 Kg respectively making it a total of 2.58 Kg for every 1 Kg of cork.

Table 10. Results of LCA for cork. (Granta Edupack)

Phase	Energy (MJ)	Energy (%)	CO ₂ footprint (kg)	CO ₂ footprint (%)
Material	52.1	82.6	1.76	68.2
Manufacture	10	15.9	0.75	29.0
Transport	0.797	1.3	0.0573	2.2
Use	0	0.0	0	0.0
Disposal	0.2	0.3	0.014	0.5
Total (for first life)	63.1	100	2.58	100
End of life potential	-52.1		-1.76	

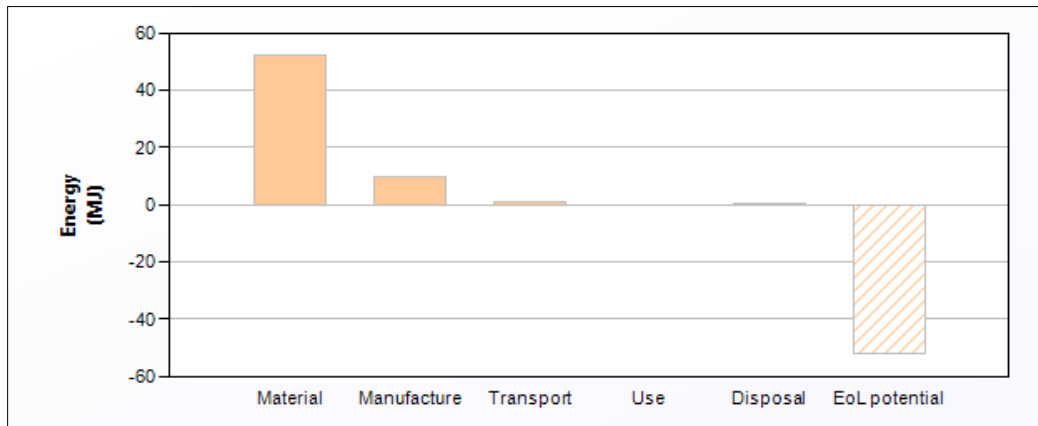

Figure 31. Energy consumption for recycled cork. (Granta Edupack)

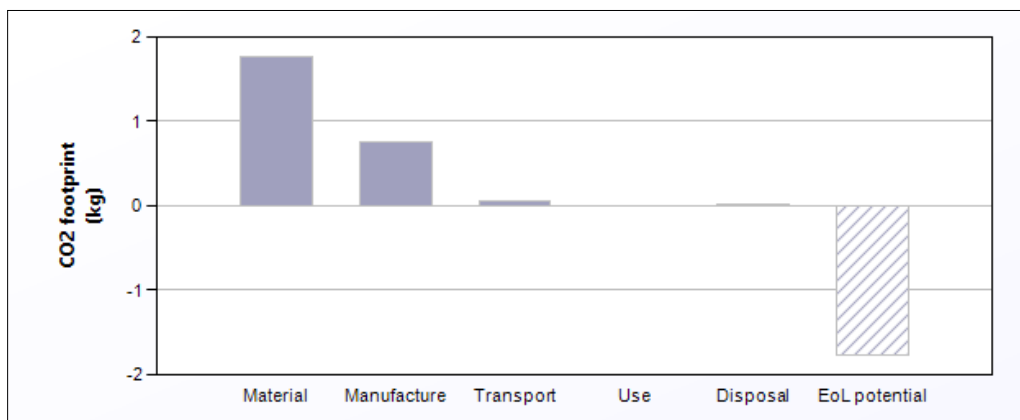

Figure 32. CO₂ emissions for cork. (Granta Edupack)

5.2.3. Fiber glass

The fiberglass has an impact during extraction, manufacture, transport, and disposal (Table 12, Figures 33 and 34) because it is a complicated material that is composed of different extracted components that are manufactured to obtain the final material of fiberglass. The energy required to extract, manufacture, transport and dispose are 122 MJ, 17.4 MJ, 0.09 MJ and 0.2 MJ, respectively, making it a total of 140 MJ for

every 1 Kg of cork. The CO₂ footprint of extraction, manufacture, transport and disposal are 6.42 Kg, 1.31 Kg, 0.006 Kg and 0.014 Kg, respectively, making it a total of 7.74 Kg for every 1 Kg of fiberglass.

Table 11. Results of LCA for fiberglass. (Granta Edupack)

Phase	Energy (MJ)	Energy (%)	CO ₂ (kg)	CO ₂ (%)
Material	122	87.4	6.42	82.9
Manufacture	17.4	12.4	1.31	16.9
Transport	0.09	0.1	0.00648	0.1
Use	0	0.0	0	0.0
Disposal	0.2	0.1	0.014	0.2
Total	140	100	7.74	100
EOL potential	-59.7		-3.1	

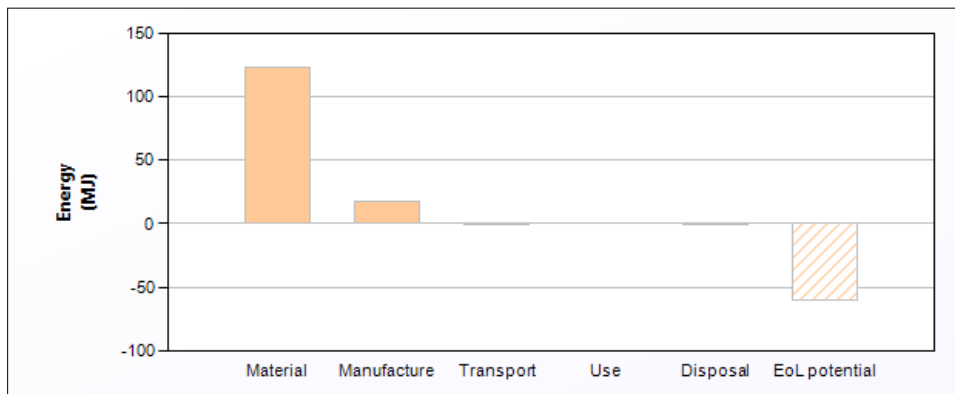

Figure 33. Energy consumption for fiberglass. (Granta Edupack)

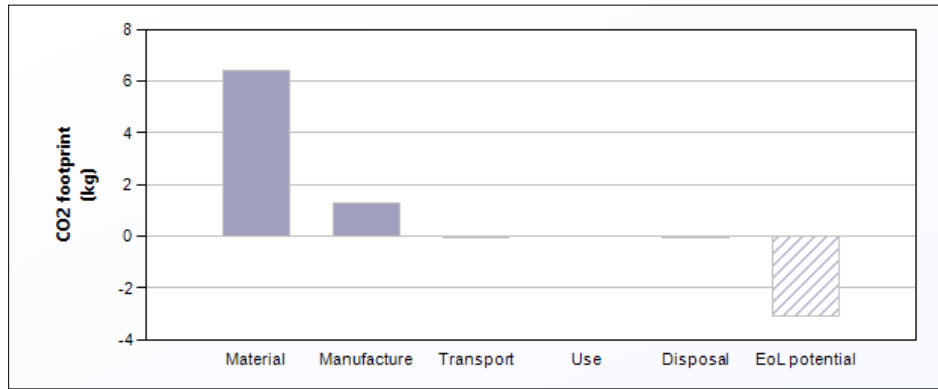

Figure 34. CO₂ emissions for fiberglass. (Granta Edupack)

5.2.4. Normal plastic

The plastic has an impact during extraction, manufacture, transport, and disposal (Table 13) and (Figure 35 and 36). Plastic is not a natural material, but it is derived from natural, organic materials such as cellulose, coal, natural gas, salt and, of course, crude oil. The energy required to extract, manufacture, transport and dispose are 56.4 MJ, 16.8 MJ, 0.113 and 0.2 MJ respectively making it a total of 73.5 MJ for every 1 Kg of plastic. The CO₂ footprint of extraction, manufacture, transportation, and disposal are 2.23 Kg, 1.26 Kg, 0.0081 and 0.014 Kg respectively making it a total of 3.52 Kg for every 1 Kg of plastic.

Table 12. Results of LCA for normal plastic. (Granta Edupack)

Phase	Energy(MJ)	Energy(%)	CO ₂ (kg)	CO ₂ (%)
Material	56.4	76.7	2.23	63.5
Manufacture	16.8	22.9	1.26	35.9
Transport	0.113	0.2	0.0081	0.2
Use	0	0.0	0	0.0
Disposal	0.2	0.3	0.014	0.4
Total (for first life)	73.5	100	3.52	100
End of life potential	-53.4		-2.02	

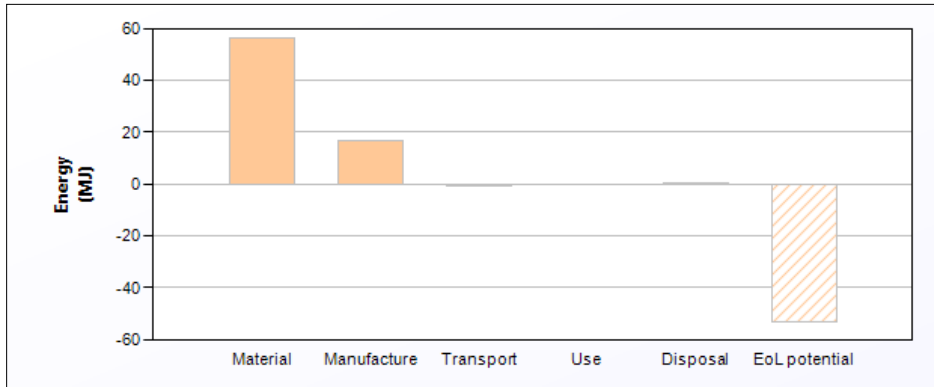

Figure 35. Energy consumption for normal plastic. (Granta Edupack)

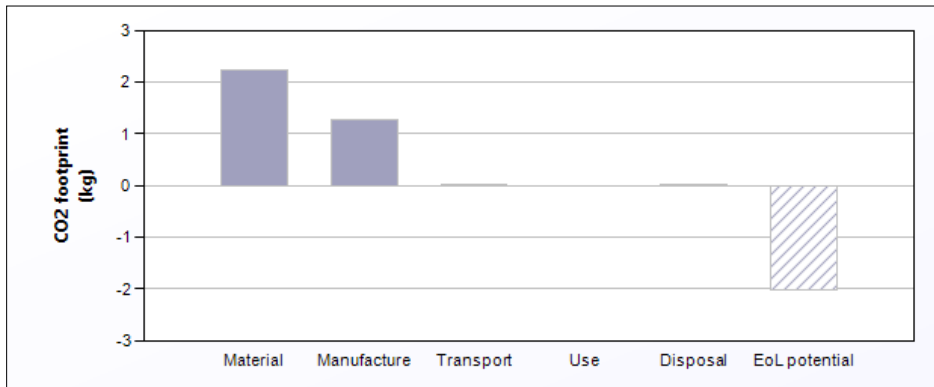

Figure 36. CO₂ emissions for normal plastic. (Granta Edupack)

The total cost extracting, manufacturing and transporting 1 Kg for each material is calculated via Granta Edupack as follows: Fiber glass \$15.2 , Plastic \$3, Cork \$11.6 and Recycled plastic \$1.7. The values are compared in Figure 37, they are based on manufacturing country (Türkiye), processes of manufacturing, transportation type and distance which are all indicated in section ‘5.1 Input’. This data will be used to roughly estimate the best solution cost. The cost of recycled plastic is \$1.7 for Kg since the size of the alternatives is about 30x30x20cm and 50x50x20 cm, each weight roughly 150 g so each cost \$0.25. The cost of soil is \$0.4 per module, arugula is \$1 while Pachysandra costs \$1.5. total cost of each façade and roof module is about 2.15 and \$1.65, respectively.

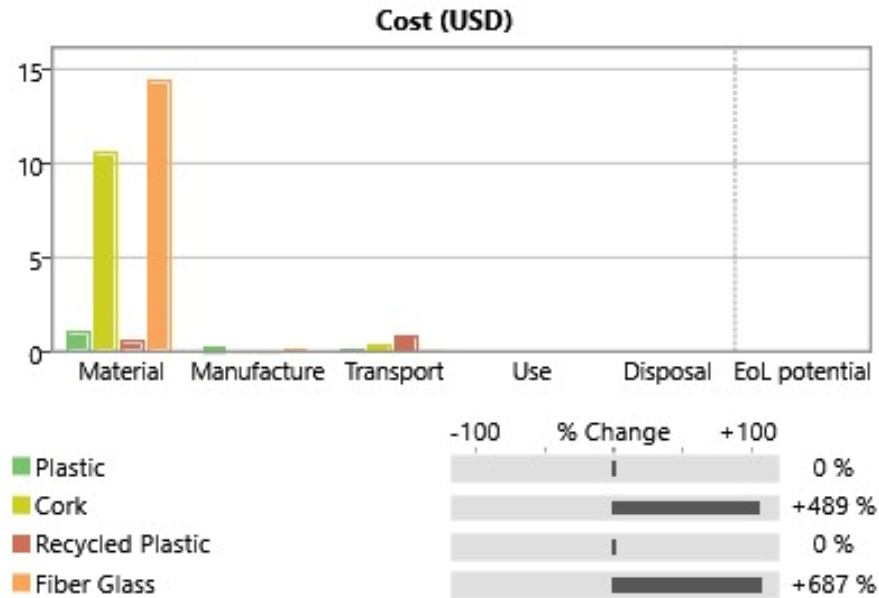

Figure 37. Cost analysis of module materials. (Granta Edupack)

5.3. Discussion

The energy consumption for fiberglass is very high during extraction and manufacturing because it is composed of resins and fiberglass that needs to be extracted separately, transported, and then added together in the manufacturing process. The indicated value of energy consumption is about 150 MJ but if we counted the end-of-life potential it is reduced to about 95 MJ, this reduction is due to the possibility of reusing and recycling it.

The cork and plastic have similar consumptions as seen in Figure 38; they consume less energy in extraction than fiberglass because they are composed of only one material. Moving to recycled plastic, it is the best material to use because it is basically manufactured with molding process. In terms of energy consumption: recycled plastic is the best to use after which come cork and plastic; the worst option with the highest energy consumption is fiberglass.

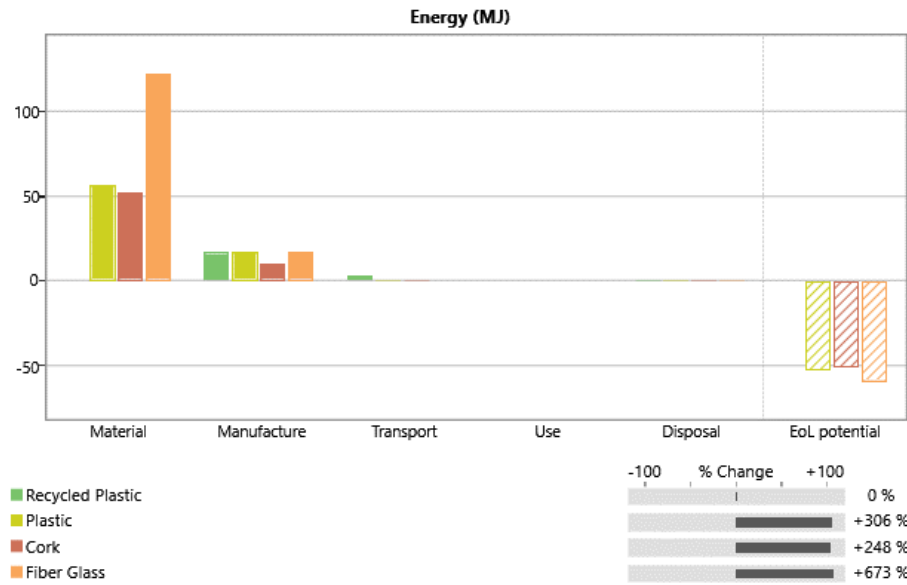

Figure 38. Energy consumption of plastic, recycled plastic, cork, and fiber glass over their lifespan. (Granta Edupack)

The CO₂ footprint of fiberglass is very high during extraction and manufacturing due to the reasons stated for energy consumption. The estimated value for CO₂ is about 6 Kg but if we counted the end-of-life potential it is reduced to about 3 Kg, which is due to the possibility of reusing and recycling it.

The cork and plastic have similar emission values as seen in Figure 39; they emit less in extraction than fiberglass because they are composed of only one material. Plastic is the best selection because of the same reason stated for energy consumption, which it requires only one manufacturing process. In terms of CO₂ footprint: recycled plastic is the best to use after which come cork and plastic; the worst option with the highest CO₂ footprint is fiberglass.

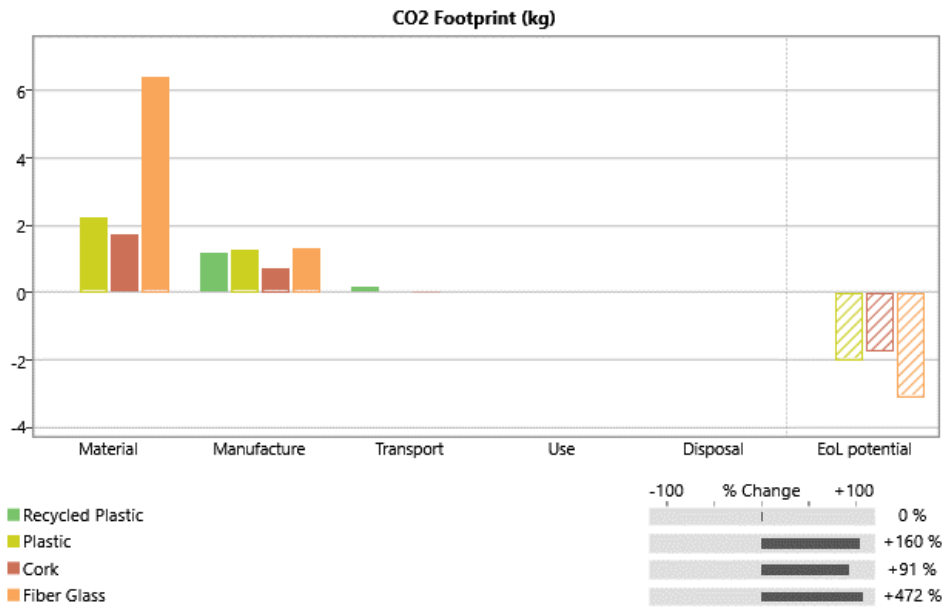

Figure 39. CO₂ emissions of plastic, recycled plastic, cork, and fiber glass over their lifespan. (Granta Edupack)

CHAPTER 6

ENERGY SIMULATION SCENARIOS

Energy simulations were conducted on the building level. A calibrated base simulation was performed to obtain a model that represents existing conditions of the case building, while another six models were generated based on the alternatives of the study. This chapter intends to examine the effect of MGs on the roof and façade systems in a real building via using DesignBuilder simulation software, based on the determined alternatives (Chapter 4 and Chapter 5). The results of the simulations were to indicate which roof alternative (RA1, RA2 or RA3) and Façade alternative (FA1, FA2, or FA3) present the least energy consumption. All the systems employed recycled plastic as the module material, which was based on results of LCA study conducted in Chapter 5.

6.1. Input

In this section all the major technical data that were used in the DesignBuilder software are explained. The input categories of DesignBuilder are included as the subsections.

6.1.1. Weather File

The outdoor weather data for the indoor monitoring period of January 5 to February 5, 2023, are shown in Figure 40 with maximum and minimum values indicated. The data represented in the graphs were supplied by Turkish State General Directory of Meteorological Service for Urla location in 10 minutes interval. Average

values of outdoor air dry-bulb temperature, atmospheric pressure, wind speed, wind direction and relative humidity are 11.0 °C, 1009 hPa, 4.3 m/s, 161 ° and 76.6 %, respectively.

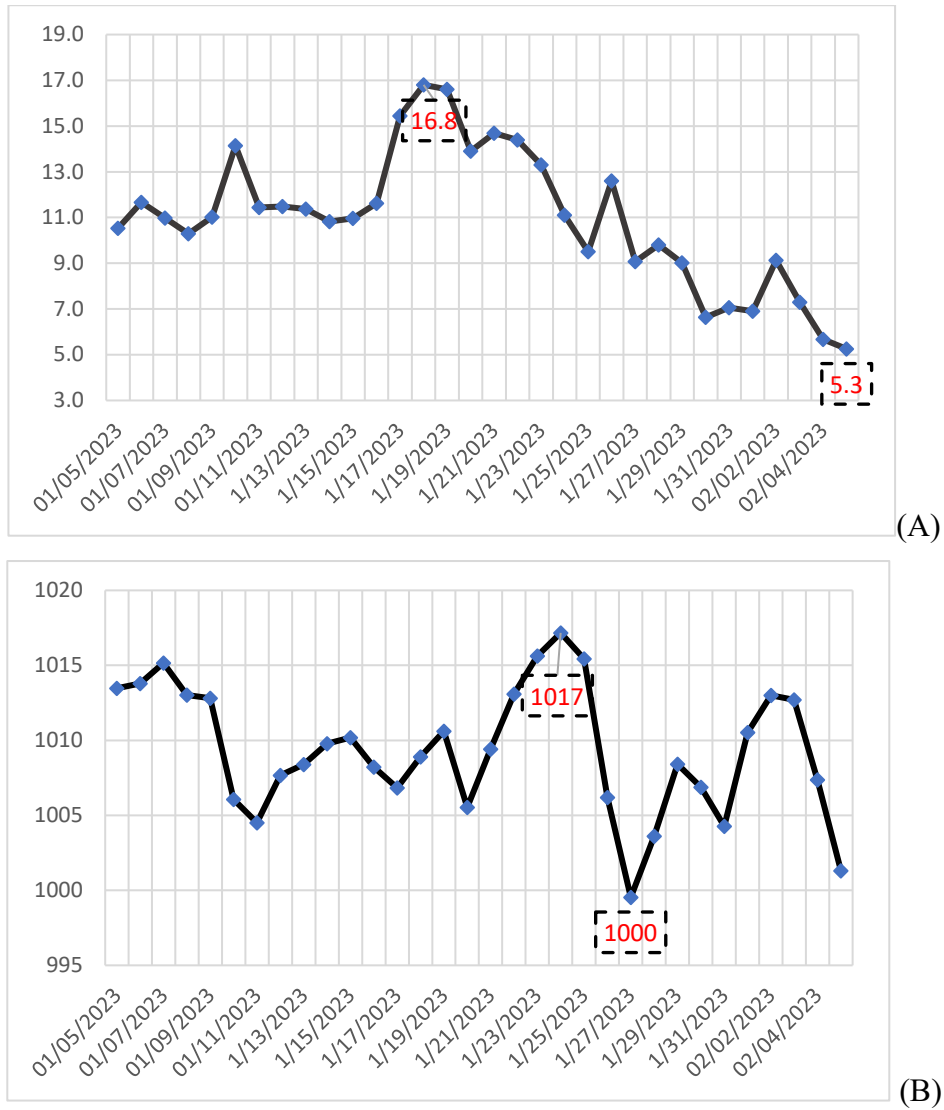

Figure 40. Daily line graphs of (A) temperature (°C), (B) pressure (hPa), (C) wind speed (m/s), (D) wind direction (degree) and (E) relative humidity (%) for 05.01-05.02.2023

(cont. on next page)

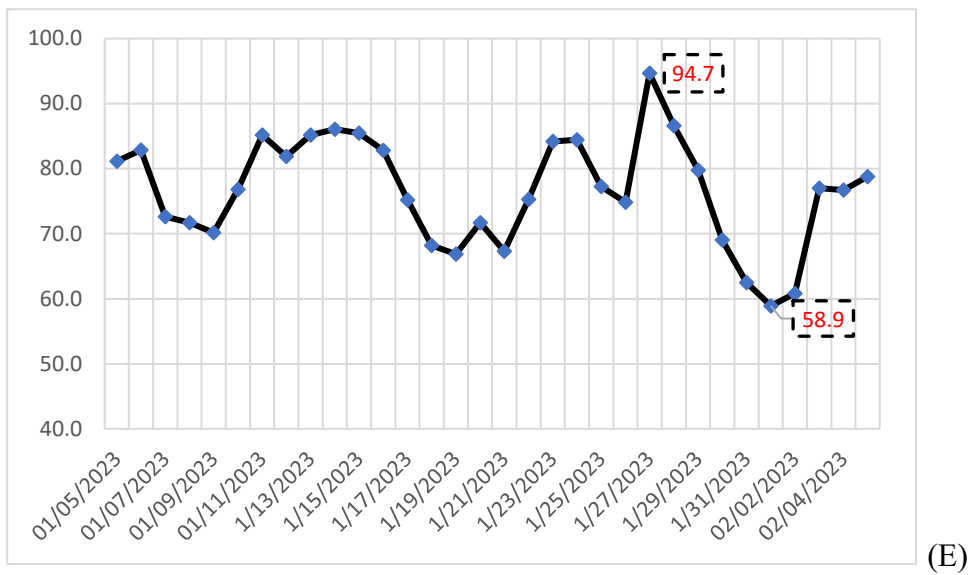
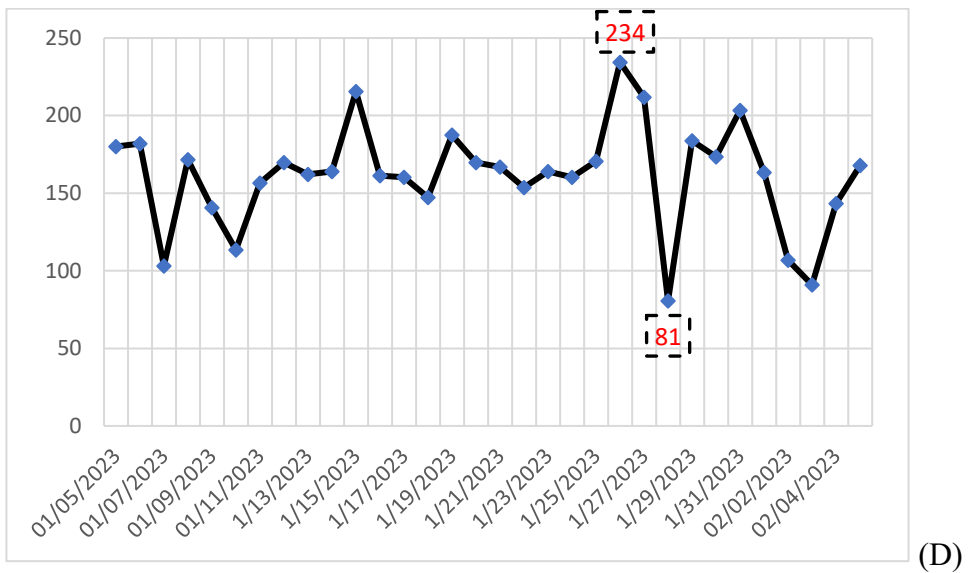
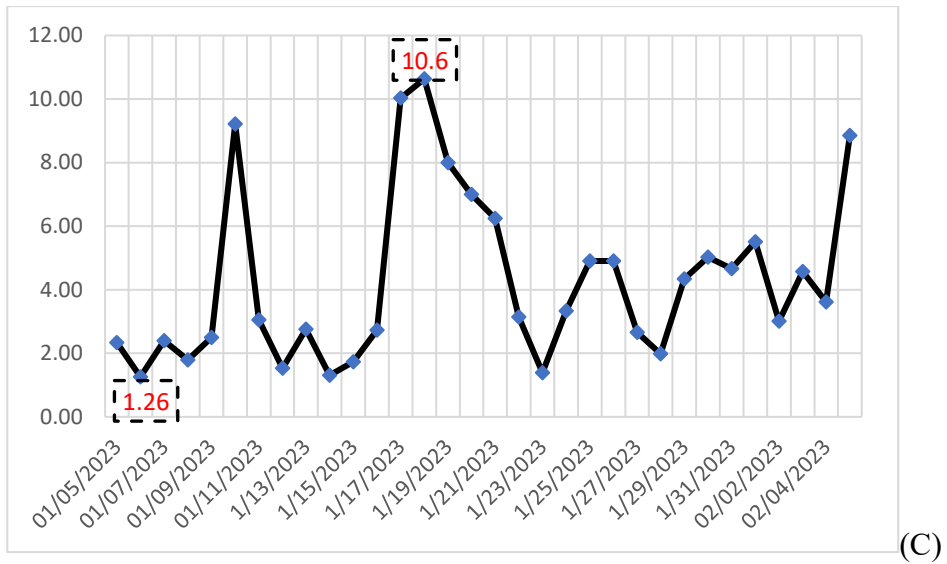

Figure 40 (cont.)

The weather file used in the software is the IWEC file format that has been partially edited. A new set of weather data that includes temperature, relative humidity, wind speed and direction, and atmospheric pressure provided by the Turkish State General Directory of Meteorological Service has been replaced in the base file (exists in the software) for the date range of indoor monitored data (from 5 January to 5 February). The new data is specific to the Urla location which will make the simulation model more reliable and allow for precise calibration. This process starts with cloning Çesme weather file in IWEC format generated from the Meteonorm Software (Meteonorm Software, 2006), allowing to keep the original file intact and edit the copy as needed. The properties of the file like name, latitude, longitude and elevation are altered. Then the most important part is replacing the required hourly weather data. Once the file is saved, it becomes available as a weather file and can be selected easily inside the DesignBuilder model. This process was done using E+ program (EnergyPlus wather converter) that convert weather data to EPW format which can be read by EnergyPlus.

6.1.2. Calibration of the Model

Model calibration was done as part of identifying a unique set of model parameters that offer a good representation of the building's performance. In this case the parameter is the air temperature of a room inside the building. This is accomplished by comparing model predictions to real measurements done on the building via reducing the huge set of measured data to averages and then applying them to standard calibration equations and specific graphs. This ultimately can show if the model is accurate enough to conduct the study variables on it.

6.1.2.1. Measurements

The basic climatic parameters of the space, including air temperature and relative humidity, were recorded at ten-minute intervals for 34 days, commencing on 4 January 2023 and ending on 8 February 2023. Monitoring was carried out using Onset HOBO U-10 datalogger placed in the meeting room on the ground floor at the center of the exterior wall. Figure 41 shows the positions of the dataloggers on the building's plan, as well as image of the location. The room have one large window that has curtains, the HVAC was on during the day. The light was only on when the room is occupied, and the door is closed most of the time. The specifications of datalogger for T and RH measurements can be seen at Table 14. The compared daily T, and RH measurements of the room which was monitored by Onset HOBO U-10 datalogger against outdoor values are shown in Figure 42.

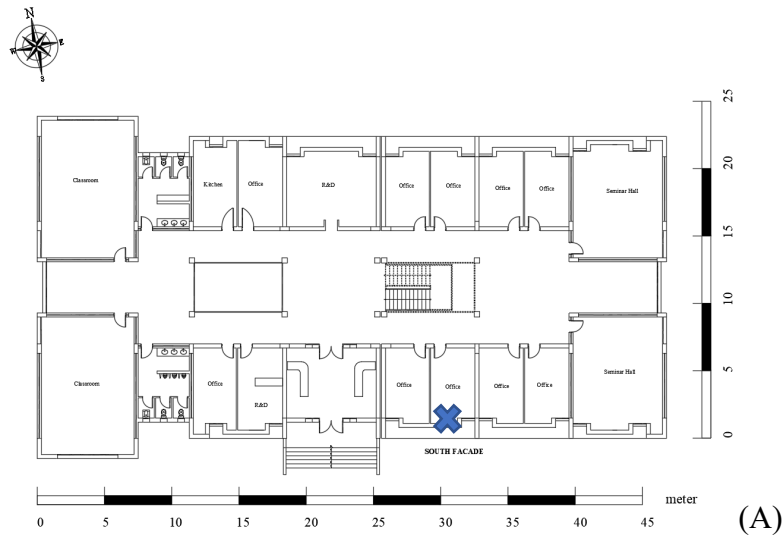

Figure 41. Location of the datalogger in (A) plan and (B) the meeting room.

Table13. Properties of HOBO U-10 data logger.

Item	T (°C)	RH (%)
Operating Range	-20 to 70	5 to 95
Uncertainty	±0.35	±2.5
Uncertainty Range	0 to 50	10 to 90

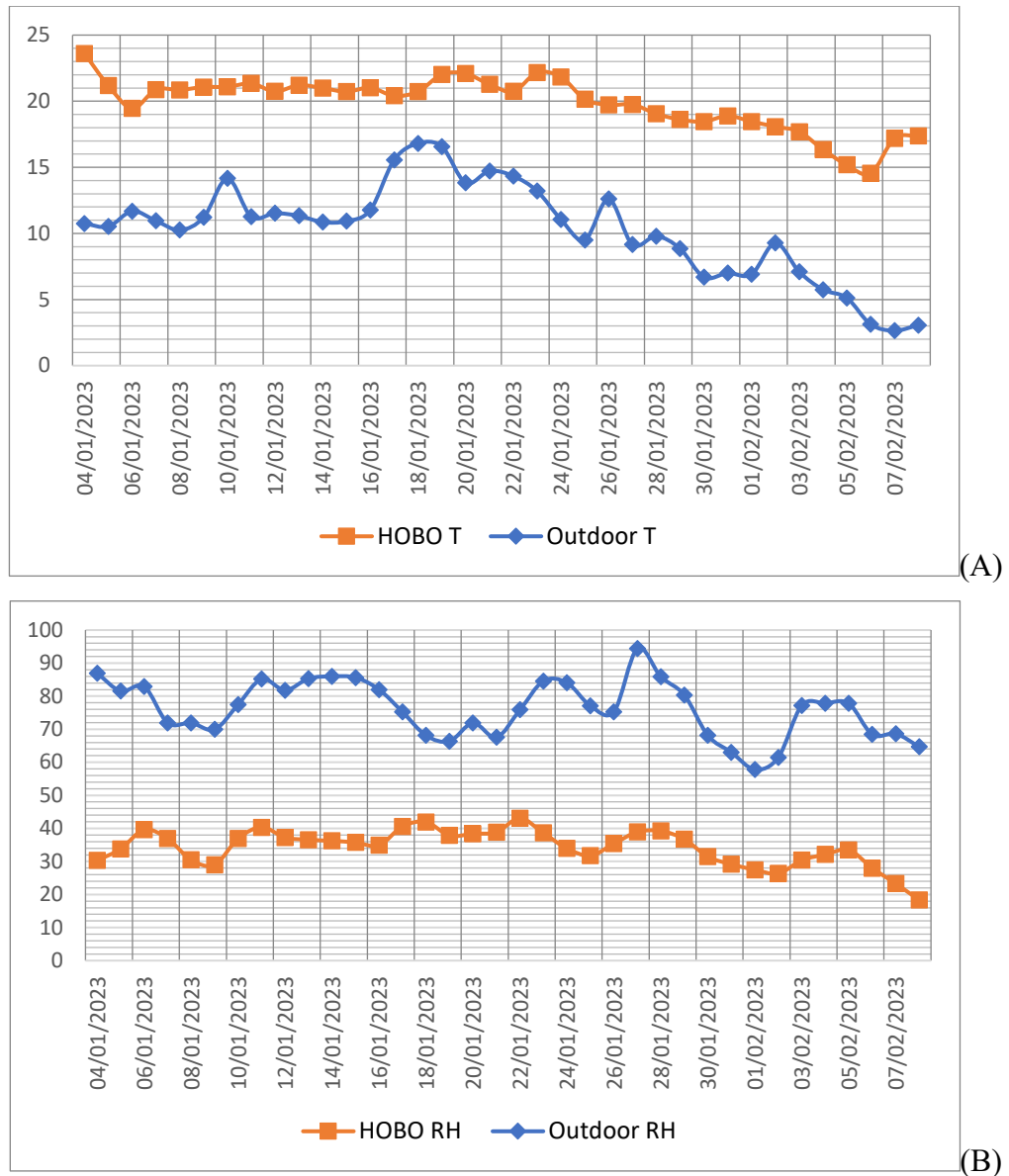

Figure 42. Daily averages of indoor measurements and outdoor (A) temperature ($^{\circ}\text{C}$) & (B) Relative humidity (%) (HOBO U-10) (Turkish State General Directory of Meteorological Service)

6.1.2.2. Calibration protocol

The Mean Bias Error (MBE) and the Root Mean Square Error (RMSE) Coefficient of Variation were employed in this study to quantify the difference between the measurement and simulation results. In general, models are said to be calibrated if

they provide MBEs within $\pm 10\%$ and RMSE within $\pm 30\%$ when implementing hourly data (ASHRAE, 2002). Measurement, simulation, and number of data are each represented by the letters T_m , T_s , and n , respectively in equations 6.1 and 6.2. Both display the values difference; therefore, the more accurate simulation results are indicated by the lower amount. Additionally, a sign from the MBE can be used to identify over- or underfitting. (Im et al., 2019)

$$6.1 \text{ RMSE} = \frac{1}{T_m} \sqrt{\frac{1}{N} * \sum (T_s - T_m)^2}$$

$$6.2 \text{ MBE} = \frac{1}{T_m} \frac{\sum_{i=1}^n (T_s - T_m)}{n}$$

The temperature and relative humidity were measured using HOBO U-10 data logger. The range of data was every 10 min for one month from 5 January to 5 February 2023. The temperature values were concise and averaged to hourly data using Microsoft excel. Then, the RMSE and MBE were calculated by using hourly temperature data to make sure that the simulation model is satisfactory according to ASHRAE standards (ASHRAE, 2002). The RMSE and MBE was found to be 8.81% and 1.95% respectively for one month as seen in Table 14. Since the RMSE is within the range of $\pm 30\%$ and MBE within the range of $\pm 10\%$, it is acceptable to proceed with the simulation model in hand. In addition, daily and hourly temperature values for simulation and monitoring over the same period show a slight difference as shown in Figure 43. Daily measured and simulated data are displayed in Table 15 where the highest difference between them found to be -4°C in 5/2/23.

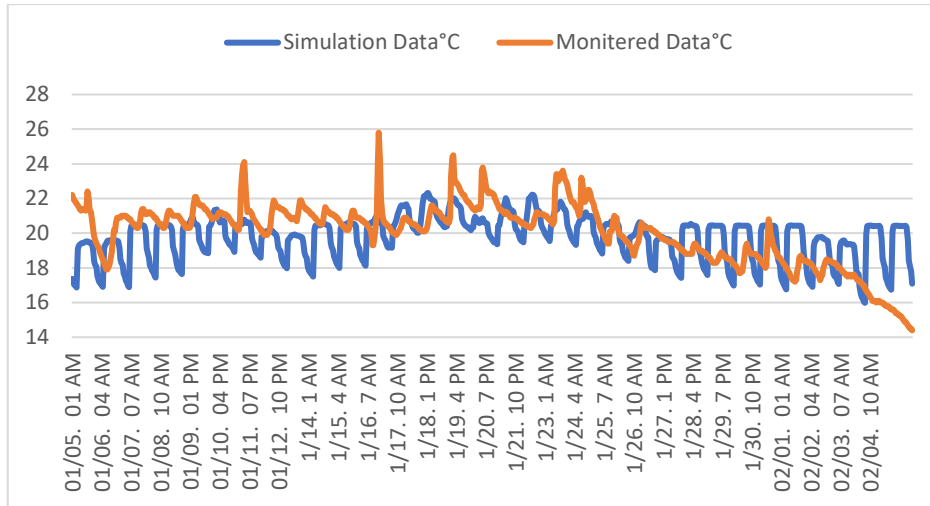

Figure 43. Hourly temperature data monitored vs simulated (°C).

Table 14. Calibration used values and results.

$\sum(T_s - T_m)$	$\sum(T_s - T_m)^2$	N	$1/N * \sum(T_s - T_m)^2$	$\sqrt{1/N * \sum(T_s - T_m)^2}$	T_{ma}	$100/T_{ma}$	RMSE (%)	MBE (%)
-304.4	2409	768	3.1	1.77	20.10	4.97	8.81	-1.95
Threshold value							±30	±10

Table 15. Daily averages of air temperature for monitored and simulation data.

Date	T_{mdaily}	T_{sdaily}	$T_{mdaily} - T_{sdaily}$
5/1/23	18.7	21.18035	2.5
6/1/23	18.8	19.4536	0.7
7/1/23	19.4	20.87361	1.4
8/1/23	19.6	20.85172	1.3
9/1/23	19.8	21.07068	1.3
10/1/23	20.2	21.08484	0.9
11/1/23	20.1	21.33648	1.3
12/1/23	19.6	20.73833	1.2
13/1/23	19.2	21.21013	2.0
14/1/23	19.7	20.99204	1.3
15/1/23	19.8	20.72204	0.9
16/1/23	20.0	21.01554	1.0
17/1/23	20.7	20.40706	-0.3
18/1/23	21.3	20.7314	-0.6

(cont. on next page)

Table 15 (cont.).

Date	T _{mdaily}	T _{sdaily}	T _{mdaily} -T _{sdaily}
19/1/23	21.1	22.0187	0.9
20/1/23	20.4	22.08852	1.6
21/1/23	20.8	21.26922	0.5
22/1/23	20.9	20.73776	-0.2
23/1/23	20.8	22.15392	1.4
24/1/23	20.4	21.83517	1.4
25/1/23	20.0	20.15245	0.1
26/1/23	19.8	19.71615	0.0
27/1/23	19.1	19.75027	0.6
28/1/23	19.6	19.04463	-0.5
29/1/23	19.5	18.6061	-0.9
30/1/23	19.4	18.46142	-0.9
31/1/23	19.4	18.89224	-0.5
1/2/23	19.3	18.45905	-0.9
2/2/23	18.8	18.07913	-0.8
3/2/23	18.6	17.69463	-0.9
4/2/23	19.1	16.34171	-2.8
5/2/23	19.2	15.18252	-4.0

6.1.3. Activity

All activity schedules were defined in DesignBuilder model as shown in Table 16. General activity is used to bulk-assign typical activity (usage) data to building models. In this case, it covers equipment usage plus heating and cooling operations for an educational building specifically in university buildings. Nevertheless, there might be difference in schedules based on the function assigned for each room. The occupancy density is 0.25 people/m² as per the recommendation of ASHRAE Standards & Guidelines (ANSI/ASHRAE, 2016). Lighting target is 300 lux, its schedule is shown in Table 18 and its type is fluorescent lighting that has the power density of 4.74 W/m². Other inputs are shown in Table 17.

Table 16. General and lighting activity schedule. (DesignBuilder)

General	Lighting
<p>Through: 03 Jan, For: AllDays, Until: 09:00, 0, Until: 17:00, 1, Until: 24:00, 0, Through: 20 Mar, For: Weekdays SummerDesignDay, Until: 07:00, 0, Until: 08:00, 0.25, Until: 09:00, 0.5, Until: 12:00, 1, Until: 14:00, 0.75, Until: 17:00, 1, Until: 18:00, 0.5, Until: 19:00, 0.25, Until: 24:00, 0, For: Weekends, Until: 24:00, 0, For: Holidays, Until: 09:00, 0, Until: 17:00, 1, Until: 24:00, 0, For: WinterDesignDay AllOtherDays, Until: 24:00, 0, Through: 03 Apr, For: AllDays, Until: 09:00, 0, Until: 17:00, 1, Until: 24:00, 0, Through: 12 Jun, For: Weekdays SummerDesignDay, Until: 07:00, 0, Until: 08:00, 0.25, Until: 09:00, 0.5, Until: 12:00, 1, Until: 14:00, 0.75, Until: 17:00, 1, Until: 18:00, 0.5, Until: 19:00, 0.25, Until: 24:00, 0, For: Weekends, Until: 24:00, 0, For: Holidays, Until: 09:00, 0, Until: 17:00, 1, Until: 24:00, 0, For: WinterDesignDay AllOtherDays, Until: 24:00, 0, Through: 25 Sep, For: AllDays, Until: 09:00, 0, Until: 17:00, 1, Until: 24:00, 0, For: Holidays, Until: 09:00, 0, Until: 17:00, 1, Until: 24:00, 0, Through: 11 Dec, For: Weekdays SummerDesignDay,</p>	<p>Through: 03 Jan, For: AllDays, Until: 09:00, 0, Until: 17:00, 1, Until: 24:00, 0, Through: 20 Mar, For: Weekdays SummerDesignDay, Until: 07:00, 0, Until: 19:00, 1, Until: 24:00, 0, For: Weekends, Until: 24:00, 0, For: Holidays, Until: 09:00, 0, Until: 17:00, 1, Until: 24:00, 0, For: WinterDesignDay AllOtherDays, Until: 24:00, 0, Through: 03 Apr, For: AllDays, Until: 09:00, 0, Until: 17:00, 1, Until: 24:00, 0, Through: 12 Jun, For: Weekdays SummerDesignDay, Until: 07:00, 0, Until: 19:00, 1, Until: 24:00, 0, For: Weekends, Until: 24:00, 0, For: Holidays, Until: 09:00, 0, Until: 17:00, 1, Until: 24:00, 0, For: WinterDesignDay AllOtherDays, Until: 24:00, 0, Through: 25 Sep, For: AllDays, Until: 09:00, 0, Until: 17:00, 1, Until: 24:00, 0, Through: 11 Dec, For: Weekdays SummerDesignDay, Until: 07:00, 0, Until: 19:00, 1, Until: 24:00, 0, For: Weekends, Until: 24:00, 0, For: Holidays, Until: 09:00, 0, Until: 17:00, 1, Until: 24:00, 0, For: WinterDesignDay AllOtherDays, Until: 24:00, 0, Through: 31 Dec,</p>

(cont. on next page)

Table 16 (cont.).

General	Lighting
Until: 07:00, 0, Until: 08:00, 0.25, Until: 09:00, 0.5, Until: 12:00, 1, Until: 14:00, 0.75, Until: 17:00, 1, Until: 18:00, 0.5, Until: 19:00, 0.25, Until: 24:00, 0, For: Weekends, Until: 24:00, 0, For: Holidays, Until: 09:00, 0, Until: 17:00, 1, Until: 24:00, 0, For: WinterDesignDay AllOtherDays, Until: 24:00, 0, Through: 31 Dec, For: AllDays, Until: 09:00, 0, Until: 17:00, 1, Until: 24:00, 0;	For: AllDays, Until: 09:00, 0 Until: 17:00, 1, Until: 24:00, 0;

Table 17. Input data for Designbuilder.

Input item	Value
Heating setpoint	20.0 °C
Heating setback	12.0 °C
Cooling setpoint	23.0 °C
Cooling setback	28 °C.
Relative humidification setpoint	10 %
Relative dehumidification setpoint	90 %
Metabolic factor	0.9

6.1.4. Construction

The specifications of structural components of the building all have assigned in DesignBuilder including material type, thickness, and thermal properties such as density, conductivity, and specific heat. It is important to inform that the author defines the structural materials based on the building construction history but the actual data for each chosen material come from a pre-existing data set ready in the software library. There are two types of walls in the model: external walls and partition walls that are different in

construction and in thermal properties as shown in Table 19. Windows construction are ‘‘Dbl Clr 6mm13mm Air’’ where there are two glass layers 6mm thick and between them with 13 mm air. Finally, the roof of the building it has a metal deck canopy-like structure on top with pitched roof. This canopy is considered as a shading element in this study and will be removed later in the simulation calculations. The structural layers of the roof will stay the same and will be the base of the design system proposed by the study for the purpose of retrofitting the building with minimal disturbance to the existing structure.

Table 18. Thermal properties of base structural components.

Component	U (W/m ² -k)	Materials (out to in)	Conductivity (W/m-K)	Specific Heat (J/kg-K)	Density (kg/m ³)	Thickness (m)
External base wall	0.472	Ceramic tiles	0.85	840	1900	0.03
		Air gap	N/A	N/A	N/A	0.01
		XPS Extruded Polystyrene	0.034	1400	35.0	0.05
		Brick	0.72	840	1920	0.20
		Cement/lime plaster	0.80	840	1600	0.015
Base roof	0.338	Bitumen, felt/sheet	0.23	1000	1100	0.01
		Glass Wool rolls	0.04	840	12	0.10
		Reinforced concrete	2.30	1000	2300	0.10
		Air gap	N/A	N/A	N/A	0.20
		Plasterboard	0.25	896	2800	0.013
Base Floor	2.772	Ceramic tiles	0.80	850	1700	0.01
		Cement	0.72	840	1860	0.025
		Reinforced concrete	2.30	1000	2300	0.10
Internal base wall	1.822	Plaster	0.16	1000	600	0.012
		Brick	0.72	840	1920	0.1

6.1.5. Effect of MGs on thermal properties of envelope

The exterior walls and roof are the components that change in terms of thermal properties after adding modular green systems. U value measures the amount of energy (heat) lost through a square meter (m²) of that material for every degree (K) difference in temperature between the inside and the outside. To create MGs, plant and plastic layers have been added above the roof and on the exterior wall base construction as illustrated in Table 19.

The plant layer shown in Figure 44 is soil layer with green roof activated in the DesignBuilder software. Once the green roof is activated it allows to choose the plant properties. This method applies for both roof and façade alternatives as indicated by DesignBuilder guidelines in modelling green envelope (DesignBuilder, 2023).

The U value for exterior walls (façade) was 0.472 W/m²-K in existing conditions and changed after applying Façade modules to FA1: 0.448. FA2: 0.443 and FA3: 0.431 W/m²-K. The U value for roof was 0.338 W/m²-K in existing conditions and changed after applying modules to RA1: 0.326, RA2 0.323, and RA3: 0.316 W/m²-K as shown in Table 19. In general, there has been decrease in U value, the lower the U-value, the less heat is lost and the more insulation the material provides.

Table 19. Thermal properties of MGs.

Component	U (W/m ² -K)	Materials	LAI	Conductivity (W/m-K)	Specific Heat (J/kg-K)	Density (kg/m ³)	Thickness (m)
FA1	0.448	Plant	2.7	1.28	880	1460	0.13
		Polythene	N/A	0.5	1800	980	0.003
		External base wall					
FA2	0.443	Plant	3.5	1.28	880	1460	0.17
		Polythene	N/A	0.5	1800	980	0.003
		External base wall					
FA3	0.431	Plant	5	1.28	880	1460	0.25
		Polythene	N/A	0.5	1800	980	0.003
		External base wall					

(cont. on next page)

Table 19 (cont.).

Component	U (W/m ² -K)	Materials	LAI	Conductivity (W/m-K)	Specific Heat (J/kg-K)	Density (kg/m ³)	Thickness (m)
RA1	0.326	Plant	2.7	1.28	880	1460	0.13
		Polythene	N/A	0.5	1800	980	0.005
		Base roof					
RA2	0.323	Plant	3.5	1.28	880	1460	0.17
		Polythene	N/A	0.5	1800	980	0.005
		Base Roof					
RA3	0.316	Plant	5	1.28	880	1460	0.25
		Polythene	N/A	0.5	1800	980	0.005
		Base Roof					

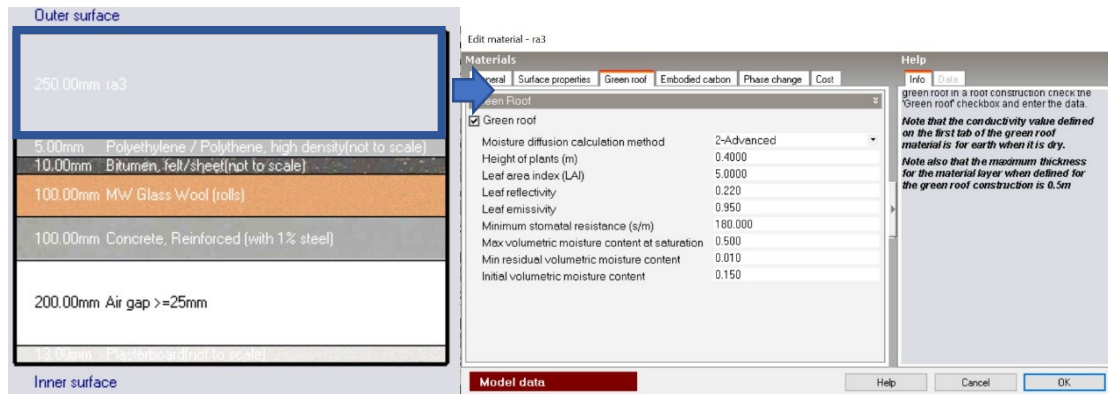

Figure 44. Example of activating green roof feature for a roof alternative.

6.1.6. HVAC

The equipment used for active cooling and heating is a fan coil unit (4-Pipe), air cooled chiller that uses oil as a fuel with heating and cooling CoP of 0.850 and 1.800. The mechanical ventilation provided is defined by outside air definition method of: Min fresh air (sum per person + per area).

6.2. Base case

The building is modeled as shown in Figures 45 and 46, and validated using data obtained through walkthrough, documents provided by IYTE staff: architect Gamze Kebenç and field measurements via onset HOBO U-10 temperature and relative humidity datalogger.

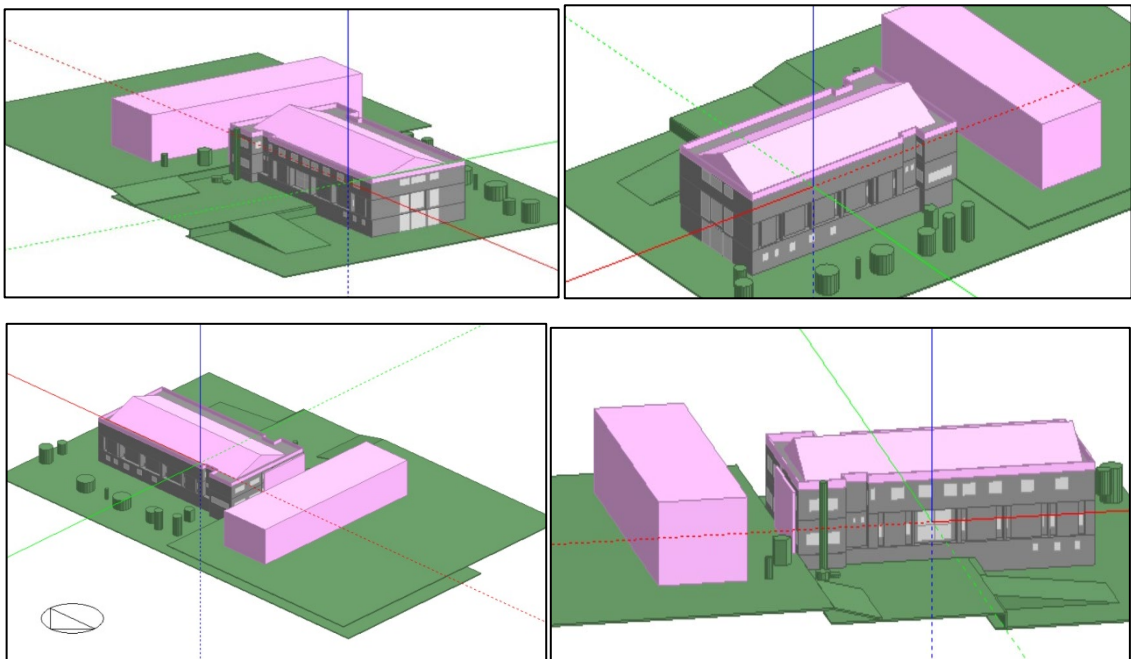

Figure 45. Software views of the base simulation model. (DesignBuilder)

The plans were simplified and inserted to DesignBuilder software where the layout, functions and arrangement is outlined (Figure 46). The function of each space helps in choosing the proper activity in the software, thus determining approximate energy consumption of the space. Basically, the activity assumes certain devices like computer will be used inside an office while a projector might be necessary in a classroom. In addition, it produces a schedule for activity in each space to determine lighting and energy usage. The base case simulation model represents the building in its existing conditions as best as possible. The preliminary simulation results (Table 20, Figure 47) shows that total yearly energy consumption is 123929 kWh, the total energy

consumption per area is 118 kWh/m². In terms of energy consumption for heating and cooling, results indicates that the focus of the future simulations will be for heating consumption during January-April and November-December while it will be for cooling consumption during May-October. The total heating and cooling consumptions for a year are 33273 and 90657 kWh whereas the heating and cooling consumptions per area is 31.7 and 86.5 kWh/m², respectively.

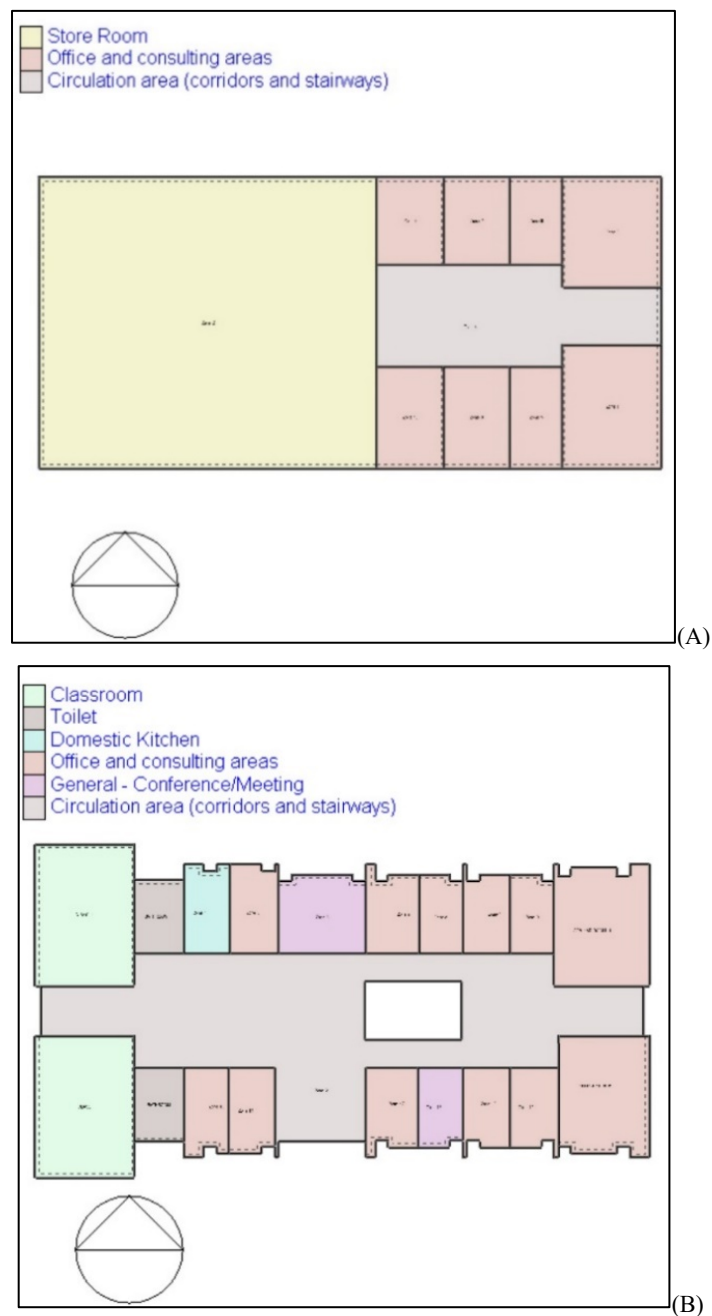

Figure 46. Software plan of (A) basement, (B) ground, and (C) first floor. (DesignBuilder)

(cont. on next page)

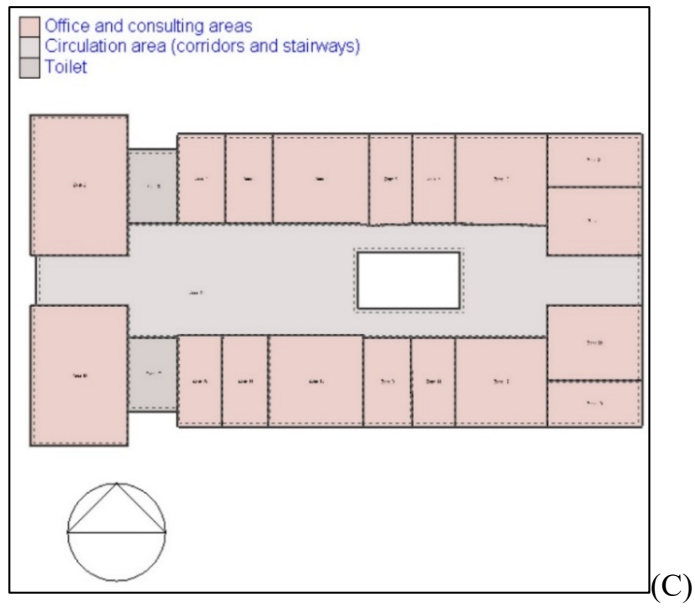

Figure 46 (cont.).

Table 20. Energy consumption for cooling and heating of base case scenario.
(DesignBuilder)

Date	Heating (KWh)	Cooling (KWh)
January	12313	4.56
February	8788	37.1
March	4235	113
April	429	1377
May	0.01	9744
June	0.00	16451
July	0.00	20809
August	0.00	21109
September	0.00	12437
October	8.3	7709
November	145	653
December	7355	213
Yearly	33273	90657

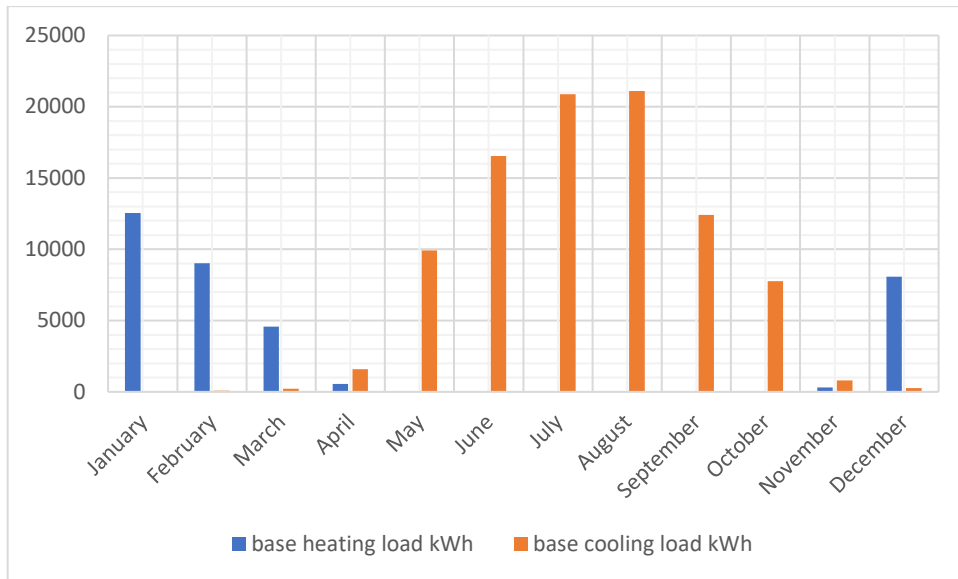

Figure 47. Energy consumption for cooling and heating graph of base case scenario (kWh).

6.3. Roof

The roof alternatives ARA1, ARA2 and ARA3 explained in Chapter 4 were tested independently as shown in Table 21 using the base case simulation model as the canvas. The parameters of this analysis were the energy consumption for heating and cooling

Table 21. Roof simulation scenarios.

ARA1	Roof alternative 1 applied on all the roof area
ARA2	Roof alternative 2 applied on all the roof area
ARA3	Roof alternative 3 applied on all the roof area

The heating consumption shown in Table 22, and Figure 48 indicate energy use reduction: ARA1, ARA2, and ARA3 reduce average monthly energy use by 6.52, 4.46, and 6.48%, respectively. The highest energy consumption for heating is primarily during January, February, March, April, November, December as indicated in Figure 49, which

favor ARA1 as the best choice for heating design because it accomplished the most savings during this period.

The cooling consumption shown in Table 23 and Figure 50 indicate relatively lower energy use reduction or increase: ARA1 and ARA3 increases cooling consumption by 3.52% and 4.17% respectively while RA2 reduce average monthly energy use by 0.28%. Thus, the roof system might not be very effective in reducing cooling consumption. The highest energy consumption for cooling is primarily during May, June, July, August, September, and October as indicated in Figure 51, which favor ARA2 as the best choice for cooling design because it accomplished the most savings during this period.

Table 22. Heating consumption of roof green module scenarios. (DesignBuilder)

Date	Energy consumption for heating (kWh)			
	Base case	ARA1	ARA2	ARA3
January	12313	11584	11772	11731
February	8788	8209	8449	8284
March	4235	3961	4053	3867
April	429	405	410	345
May	0.01	0.01	0.01	0
June	0.00	0.00	0.00	0
July	0.00	0.00	0.00	0
August	0.00	0.00	0.00	0
September	0.00	0.00	0.00	0
October	8.30	6.39	7.60	6
November	145	112	131	107
December	7355	6895	6998	6845
Average	2773	2598	2652	2599
Yearly	33273	31172	31821	31185

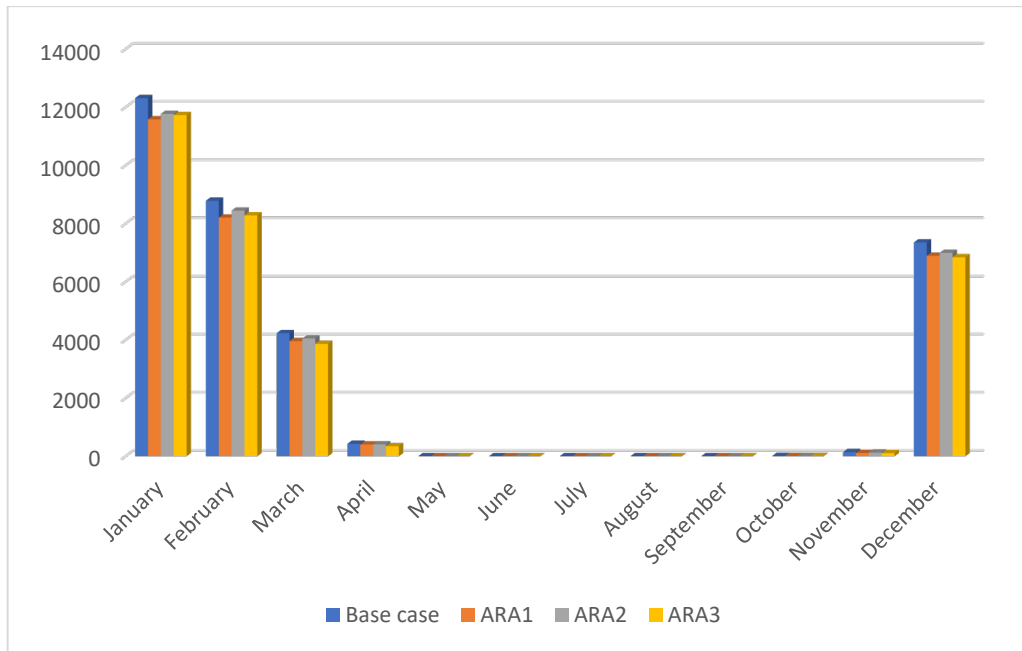

Figure 48. Heating consumption graph of roof green module scenarios (kWh).

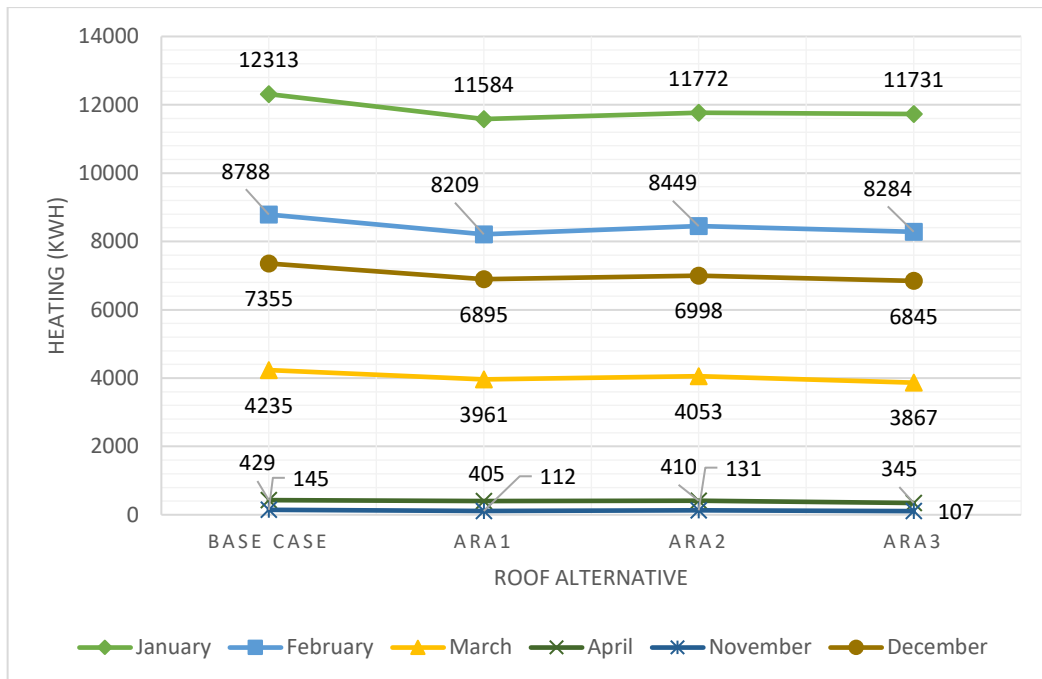

Figure 49. Heating consumption graph of roof green module scenarios (kWh).

Table 23. Cooling consumption of green roof module scenarios. (DesignBuilder)

Date	Energy consumption for cooling (kWh)			
	Base case	ARA1	ARA2	ARA3
January	4.56	10.1	7.18	8.27
February	37.05	63.8	47.8	58.9
March	113	141	125	156
April	1377	1431	1386	1552
May	9744	9808	9784	10378
June	16451	16594	16313	17042
July	20809	21562	20695	21385
August	21109	21921	20919	21723
September	12437	13109	12377	12999
October	7709	8277	7809	8233
November	653	750	722	750
December	213	245	228	244
Average	7555	7826	7534	7877
Yearly	90657	93912	90413	94529

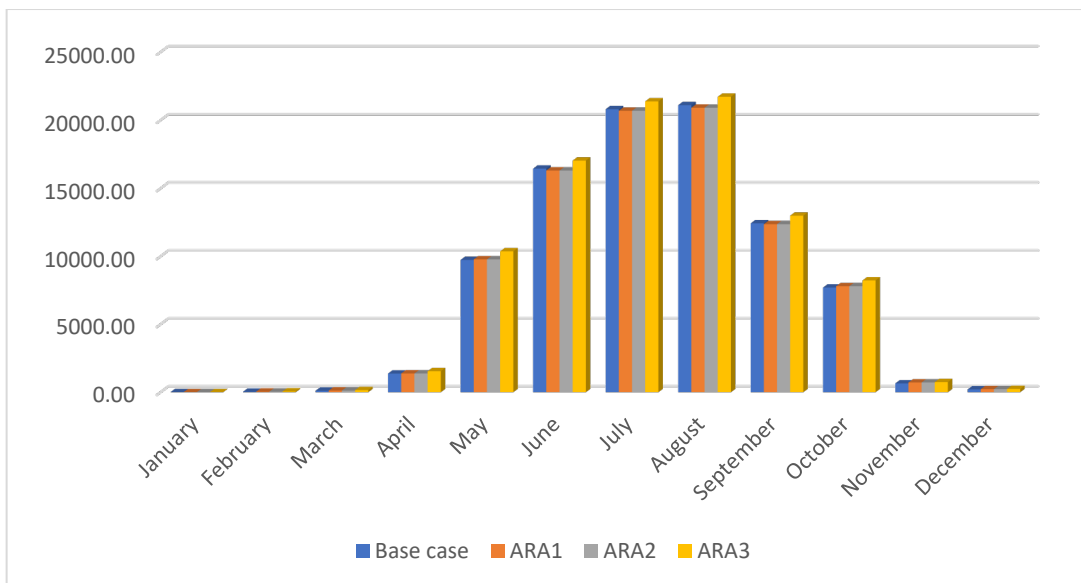

Figure 50. Cooling consumption graph of green roof module scenarios (kWh).

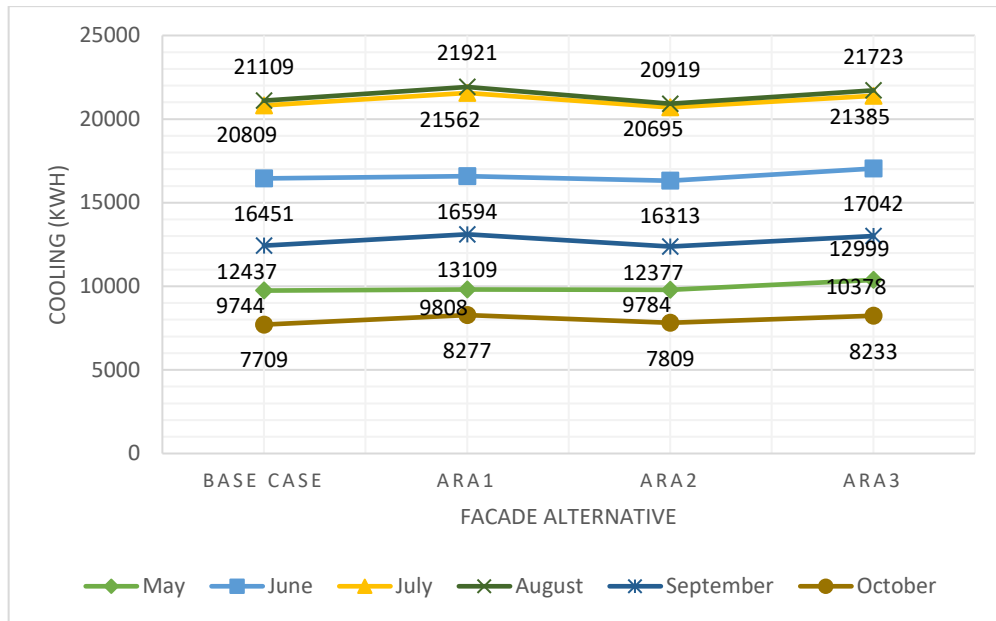

Figure 51. Cooling consumption graph of green roof module scenarios (kWh).

6.4. Façade

The scenarios for the facades system is variable. Firstly, each alternative will be applied to all facades separately (Table 24). Secondly, the alternatives is applied to each façade to have better understanding of the direction that needs the most retrofitting (Table 27). Thirdly, the alternatives is applied to parallel facades that have the same size (Table 30).

6.4.1 All Facades

The façade alternatives AFA1, AFA2, and AFA3 explained in Chapter 4 were tested independently as shown in Table 24 using the base case simulation model as the canvas. The alternatives are applied to all facades and the parameters of this analysis were heating and Energy consumption for cooling.

Table 24. Façade's simulation scenarios

AFA1	Façade alternative 1 applied on all facades
AFA2	Façade alternative 2 applied on all facades
AFA3	Façade alternative 3 applied on all facades

The heating consumption shown in Table 25 and Figure 52 show reduction in energy use: AFA1, AFA2, and AFA3 reduced energy use by 11.72, 9.59, and 7.44%, respectively. The highest energy consumption for heating is primarily during January, February, March, April, November, December as indicated in Figure 53, which favor AFA1 as the best choice for heating design because it accomplished the most savings during this period.

The cooling consumption shown in Table 26 and Figure 54 show reduction in energy use for AFA2 and AFA3 of 0.42 and 3.34%, respectively., while AFA1 showed an increased cooling consumption of 2.40 %. Thus, these results indicates that the roof system might not be very effective in reducing cooling consumption. The highest energy consumption for cooling is primarily during May, June, July, August, September, and October as indicated in Figure 55, which further show that the façade system would provide relatively lower reduction in cooling consumptions.

Table 25. Heating consumption of green façade module scenarios. (DesignBuilder)

Date	Energy consumption for heating (kWh)			
	Base case	AFA1	AFA2	AFA3
January	12313	10945	11169	11350
February	8788	7945	8148	8274
March	4235	3781	3767	3919
April	429	351	332	410
May	0.01	0	0.01	0
June	0.00	0	0.00	0
July	0.00	0	0.00	0
August	0.00	0	0.00	0
September	0.00	0	0.00	0
October	8.3	8	7	8
November	145	82.1	111	108
December	7355	6480	6689	6825
Average	2773	2466	2519	2574
Yearly	33273	29592	30223	30894

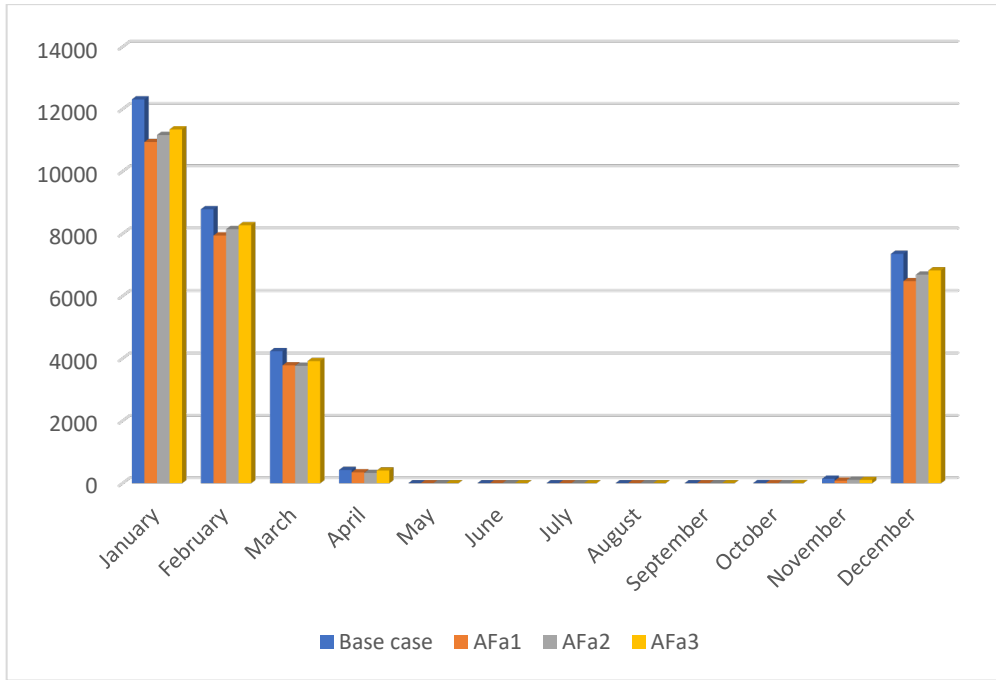

Figure 52. Heating consumption graph of green facade module scenarios (kWh).

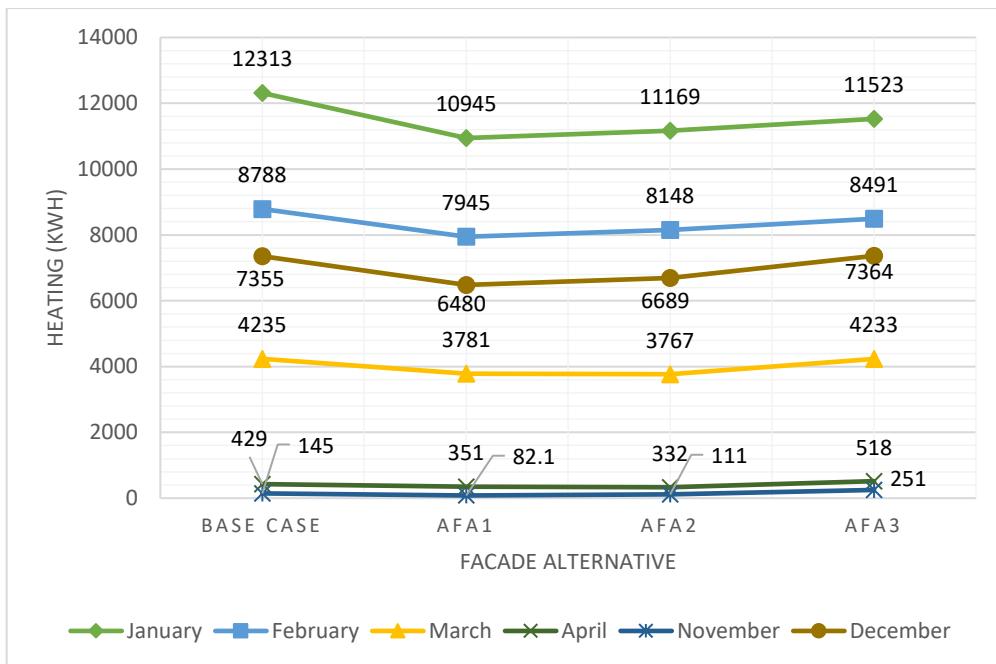

Figure 53. Heating consumption graph of green facade module scenarios (kWh).

Table 26. Cooling consumption of green façade module scenarios. (DesignBuilder)

Date	Energy consumption for cooling (kWh)			
	Base case	AFA1	AFA2	AFA3
January	4.56	8.93	4.86	3.70
February	37.05	44.2	42.9	31.3
March	113	121	134	107
April	1377	1468	1505	1331
May	9744	9945	10167	9494
June	16451	16737	16551	15923
July	20809	21837	20537	20246
August	21109	21143	20609	20456
September	12437	12649	12089	11901
October	7709	7776	7733	7344
November	653	890	690	646
December	213	243	209	199
Average	7555	7739	7523	7307
Yearly	90657	92809	90224	87647

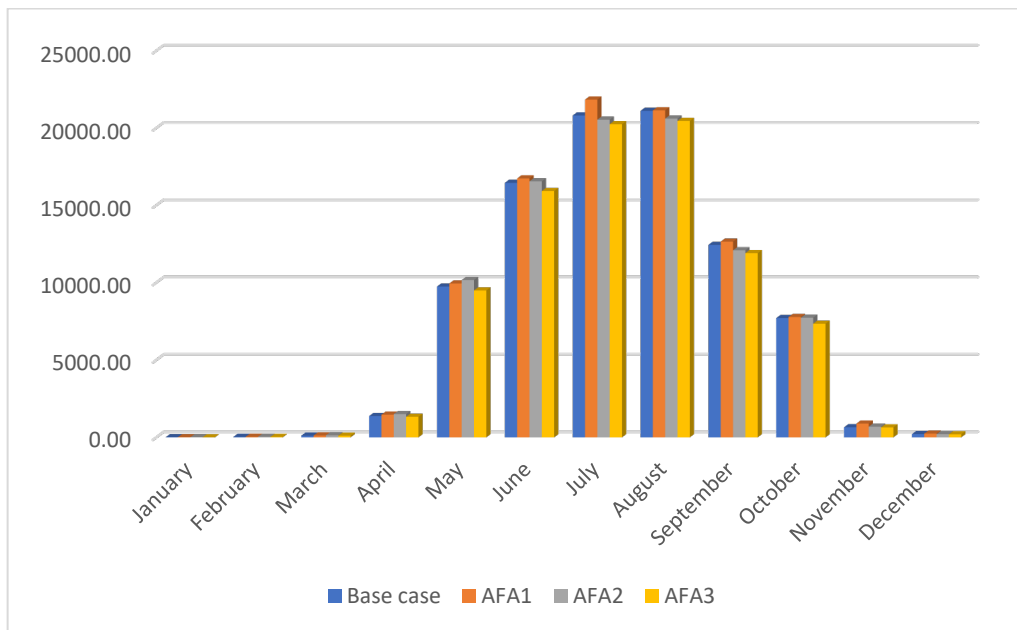

Figure 54. Cooling consumption graph of green façade module scenarios (kWh).

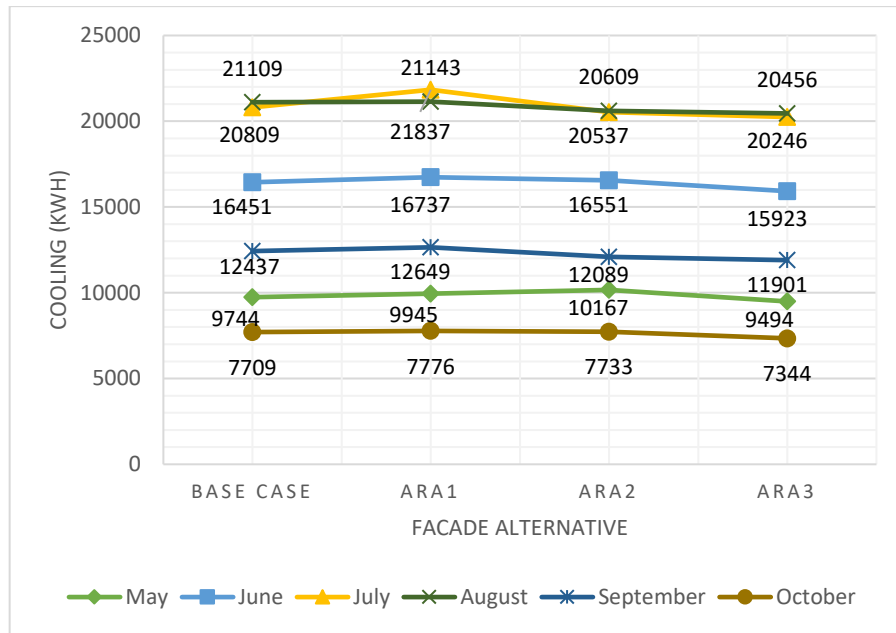

Figure 55. Cooling consumption graph of green facade module scenarios (kWh).

6.4.2. Single facades

The four facades of building will be assigned all the alternatives individually as shown in Table 27 to examine the most effective side for applying MGS and also the best alternative for each side. This can help to introduce the optimum, and most practical solution. Instead of covering the whole building a compromise between energy saving and feasibility can be achieved.

Table 27. Single facades simulation scenarios.

FA1	EFA1	Façade alternative 1 applied on East façade
	WFA1	Façade alternative 1 applied on West façade
	SFA1	Façade alternative 1 applied on South façade
	NFA1	Façade alternative 1 applied on North façade
FA2	EFA2	Façade alternative 2 applied on East façade
	WFA2	Façade alternative 2 applied on West façade
	SFA2	Façade alternative 2 applied on South façade
	NFA2	Façade alternative 2 applied on North façade
FA3	EFA3	Façade alternative 3 applied on East façade
	WFA3	Façade alternative 3 applied on West façade
	SFA3	Façade alternative 3 applied on South façade
	NFA3	Façade alternative 3 applied on North façade

According to monthly heating consumption shown in Table 28 and Figure 56, 57, 58, and 59 the best choices for East, West, South and North are EF1, WFA1, SF2, and NFA1 with reduction of 4.40, 7.50, 4.18, 8.73 %, respectively. As illustrated in Figure 60, North is the most effective side to install the FA1 alternative if one façade is to be chosen for retrofitting.

Table 28. Heating consumption for single facades simulations.

Date	Energy consumption for heating (kWh)												
	Base case	EFA1	EFA2	EFA3	WFA1	WFA2	WFA3	SFA1	SFA2	SFA3	NFA1	NFA2	NFA3
January	12313	12061	12086	12093	11746	11779	11799	12082	12086	12244	11587	11668	11782
February	8788	8438	8443	8444	8195	8221	8234	8454	8453	8797	8105	8149	8193
March	4235	3760	3752	3767	3588	3581	3598	3746	3744	4262	3533	3508	3595
April	429	295	293	296	268	267	274	293	292	439	258	250	270
May	0.01	0.01	0.01	0.01	0.01	0.01	0.01	0.01	0.01	0.01	0.01	0.01	0.01
June	0.00	0.00	0.00	0.00	0.00	0.00	0.00	0.00	0.00	0.00	0.00	0.00	0
July	0.00	0.00	0.00	0.00	0.00	0.00	0.00	0.00	0.00	0.00	0.00	0.00	0
August	0.00	0.00	0.00	0.00	0.00	0.00	0.00	0.00	0.00	0.00	0.00	0.00	0
September	0.00	0.00	0.00	0.00	0.00	0.00	0.00	0.00	0.00	0.00	0.00	0.00	0
October	8.3	6.86	6.83	6.88	5.95	5.96	6.09	6.19	7.19	8.86	6.01	5.94	6.44
November	145	125	127	127	98	103	103	134	132	150	97.5	102	107.4
December	7355	7122	7131	7142	6877	6909	6913	7273	7173	7362	6791	6869	6956
Average	2773	2651	2653	2656	2565	2572	2577	2666	2657	2772	2531	2546	2576
Annual	33273	31808	31838	31875	30778	30866	30927	31988	31887	33263	30377	30552	30912
Change (%)	N/A	-4.40	-4.33	-4.22	-7.50	-7.25	-7.07	-3.86	-4.18	-0.036	-8.73	-8.19	-7.10

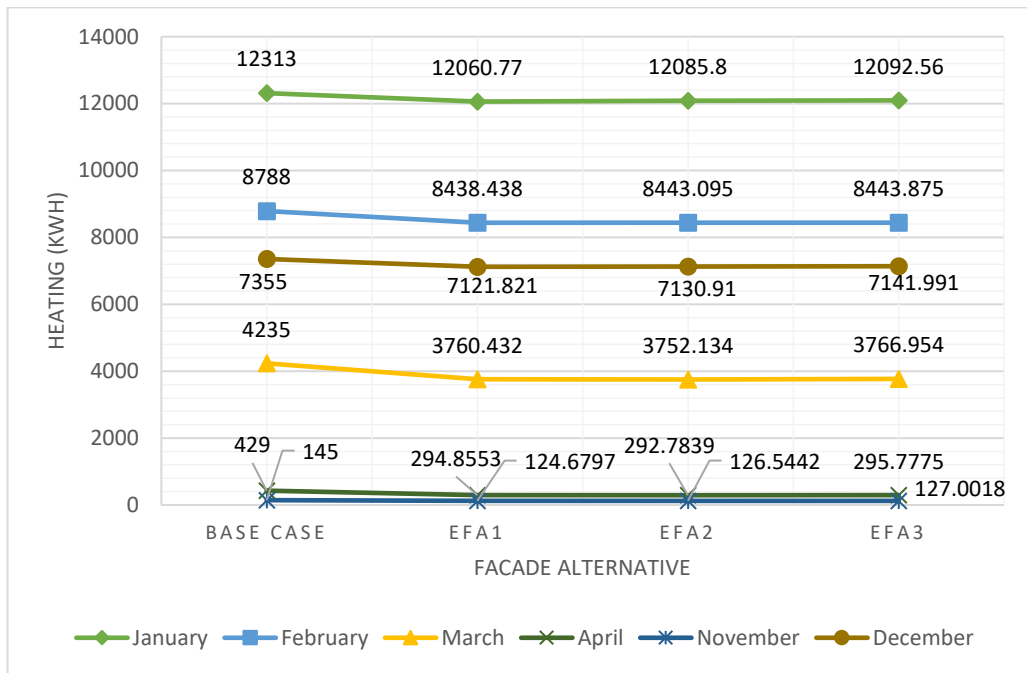

Figure 56. Monthly heating consumption for East facade simulations (kWh).

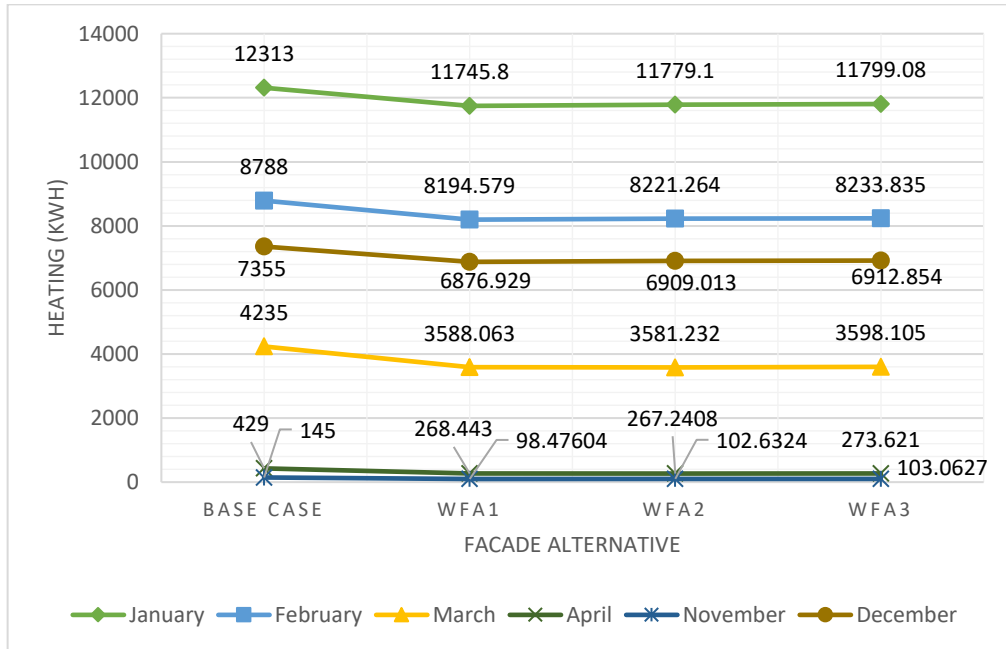

Figure 57. Monthly heating consumption for West facade simulations (kWh).

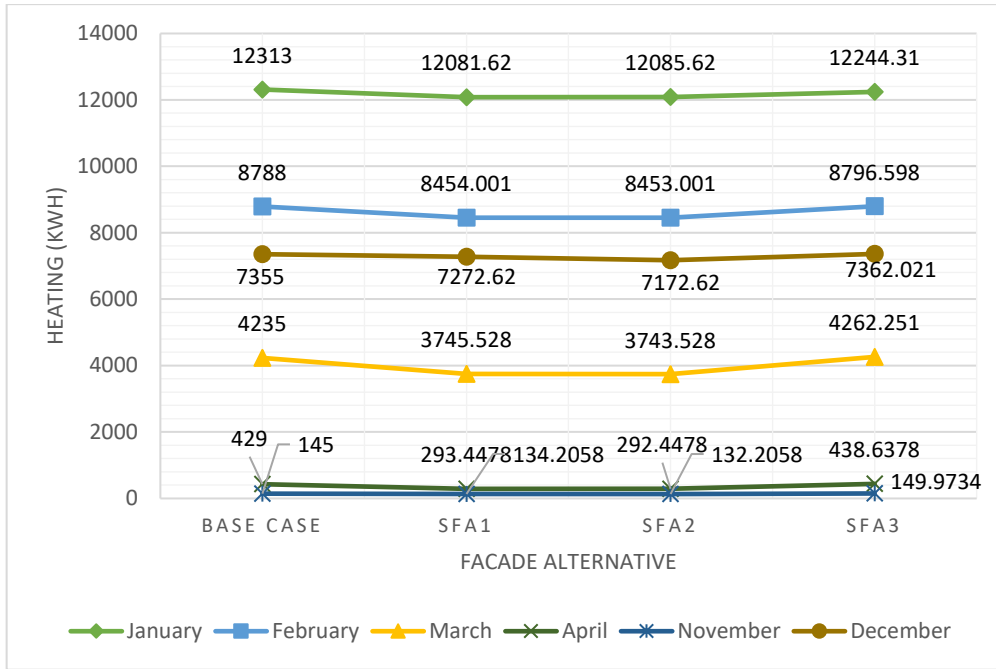

Figure 58. Monthly heating consumption for South facade simulations (kWh).

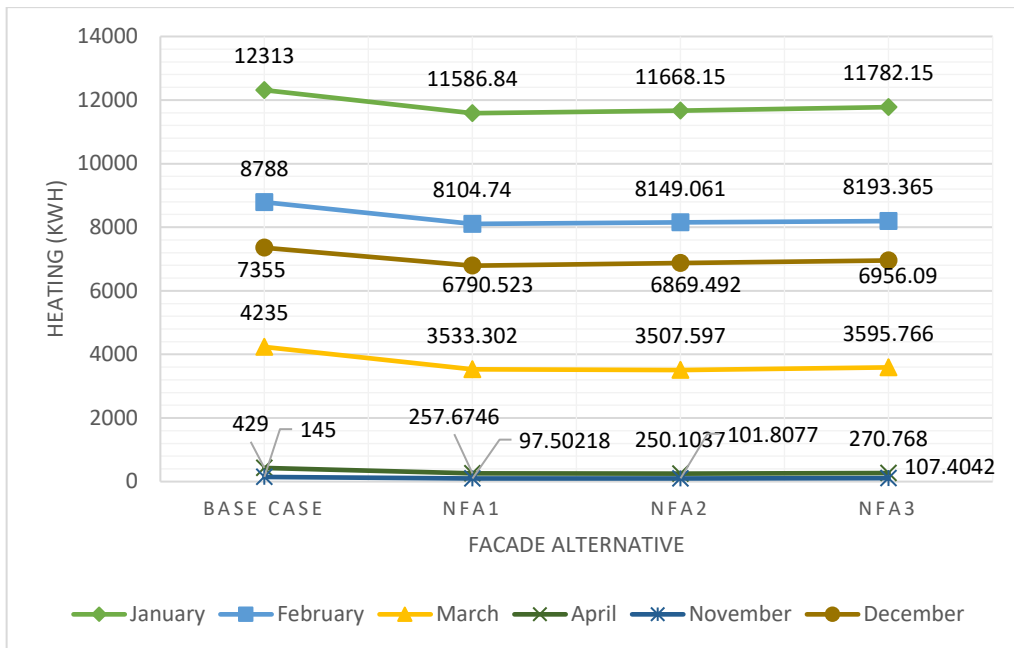

Figure 59. Monthly heating consumption for North facade simulations (kWh).

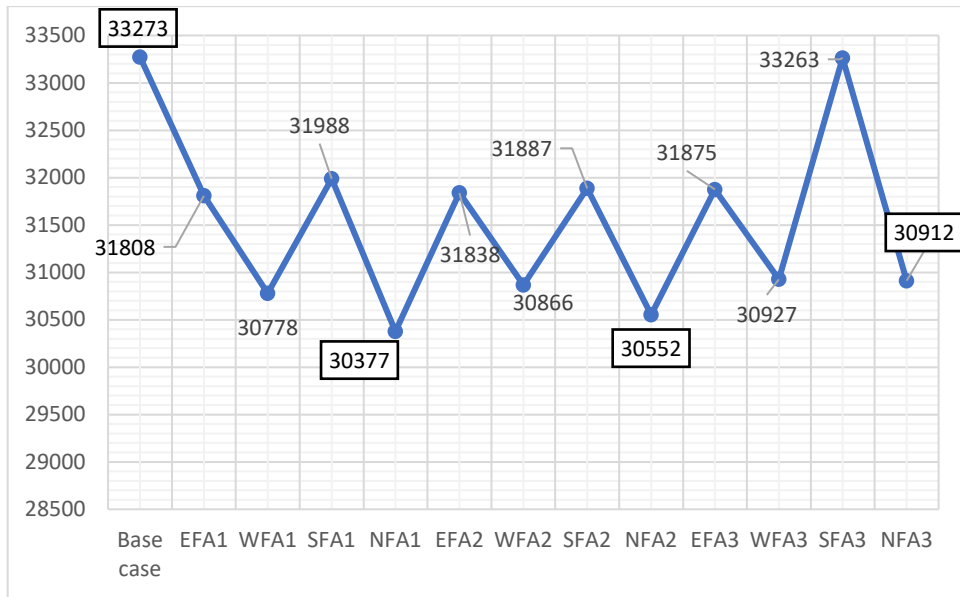

Figure 60. Annual heating consumption for single facades simulations (kWh).

According to monthly cooling consumption shown in Table 29 and Figure 61, 62, 63 and 64 the simulations scenarios showed poor results for all facades where almost all of them increased cooling consumption. As illustrated in Figure 65 only SFA3 showed a marginal decrease of 1.2 % making the south façade as the acceptable side to install the system.

Table 29. Cooling consumption for single facades simulations.

Date	Energy consumption for cooling (kWh)												
	Base case	EFA1	EFA2	EFA3	WFA1	WFA2	WFA3	SFA1	SFA2	SFA3	NFA1	NFA2	NFA3
January	4.56	5.66	5.12	5.16	6.39	6.03	5.94	5.06	4.06	3.22	5.24	5.11	5.05
February	37.1	47.8	48.8	47.4	52.8	52.6	51.4	45.6	44.6	29.0	50.6	50.7	50.2
March	113	167	173	166	183	187	182	173	170	100	185	190	181
April	1377	1721	1736	1707	1792	1795	1772	1756	1746	1332	1825	1859	1785
May	9744	10810	10836	10771	10951	10959	10880	10943	10942	9637	11064	11104	10901
June	16451	17776	17788	17723	17958	17941	17890	17867	17877	16356	17936	17960	17803
July	20809	21978	21852	21821	22208	22042	22011	21888	21880	20703	22307	21945	21887
August	21109	22499	22451	22417	22734	22685	22646	22438	22432	20892	22729	22550	22513
September	12437	13278	13252	13230	13496	13438	13408	13165	13167	12226	13500	13403	13336
October	7709	8328	8315	8277	8517	8490	8456	8185	8184	7482	8578	8514	8432
November	653	716	687	687	753	739	730	656	655	605	779	734	717
December	213	222	219	219	238	236	233	218	208	196	251	230	226
Average	7555	8129	8114	8089	8241	8214	8189	8112	8109	7464	8267	8212	8153
Annual	90657	97548	97364	97069	98890	98570	98266	97340	97310	89562	99209	98545	97836
Change (%)	N/A	+7.60	+7.40	+7.07	+9.08	+8.73	+8.39	+7.37	+7.34	-1.20	+9.43	+8.70	+7.92

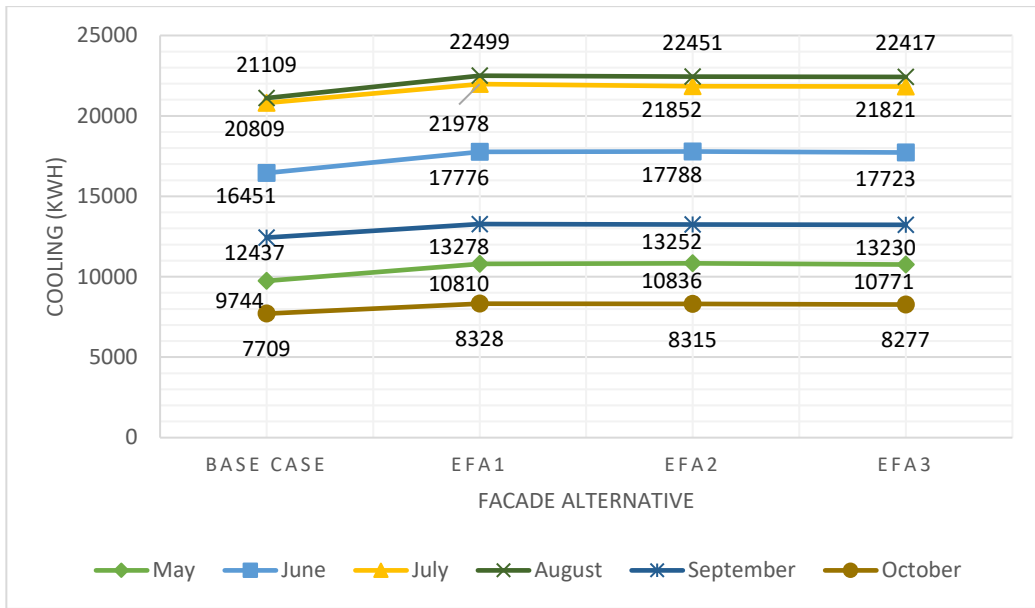

Figure 61. Monthly cooling consumption for East facade simulations (kWh).

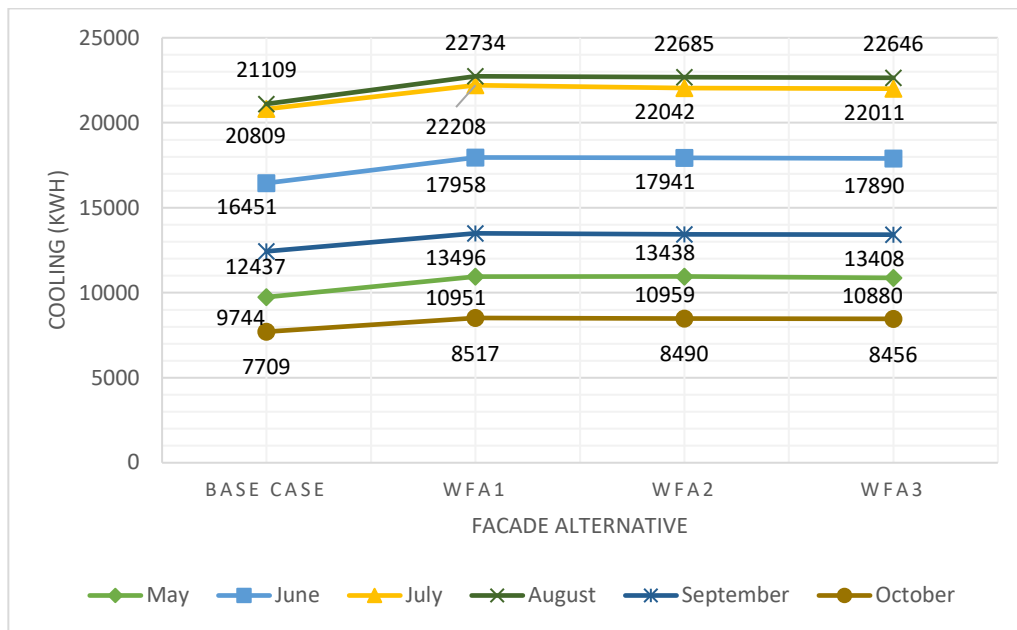

Figure 62. Monthly cooling consumption for West facade simulations (kWh).

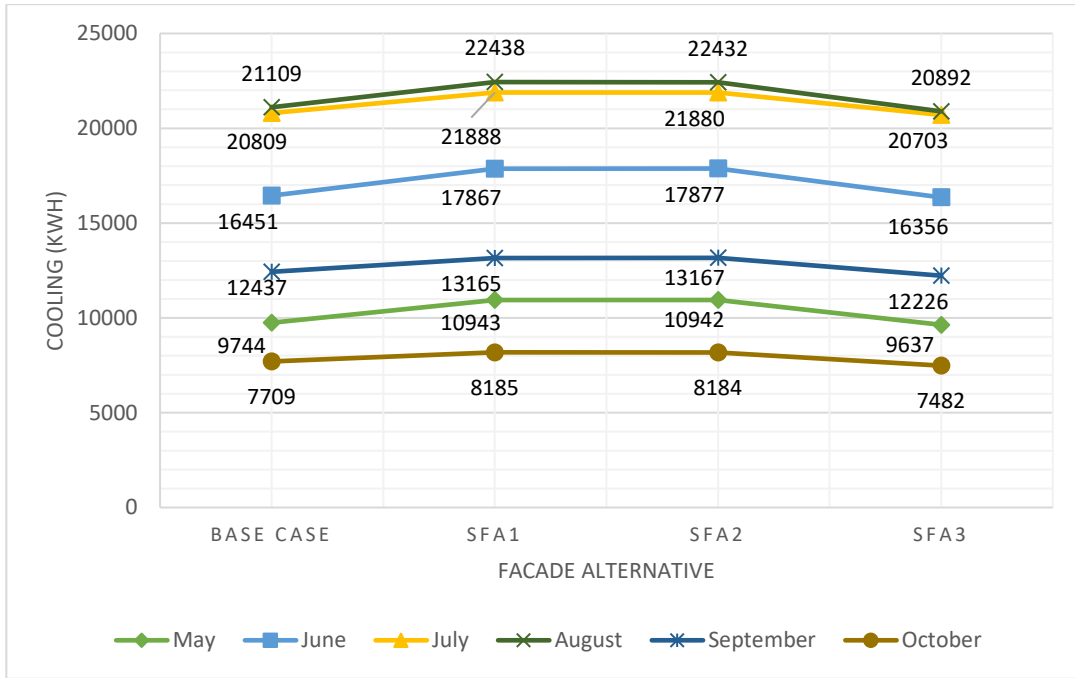

Figure 63. Monthly cooling consumption for South facade simulations (kWh).

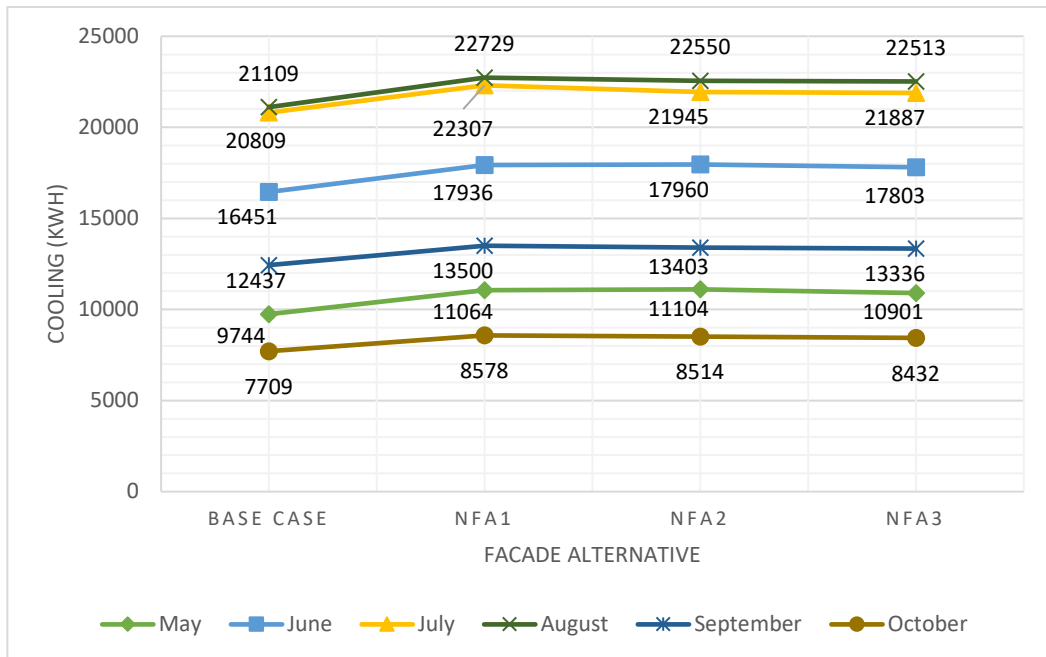

Figure 64. Monthly cooling consumption for North facade simulations (kWh).

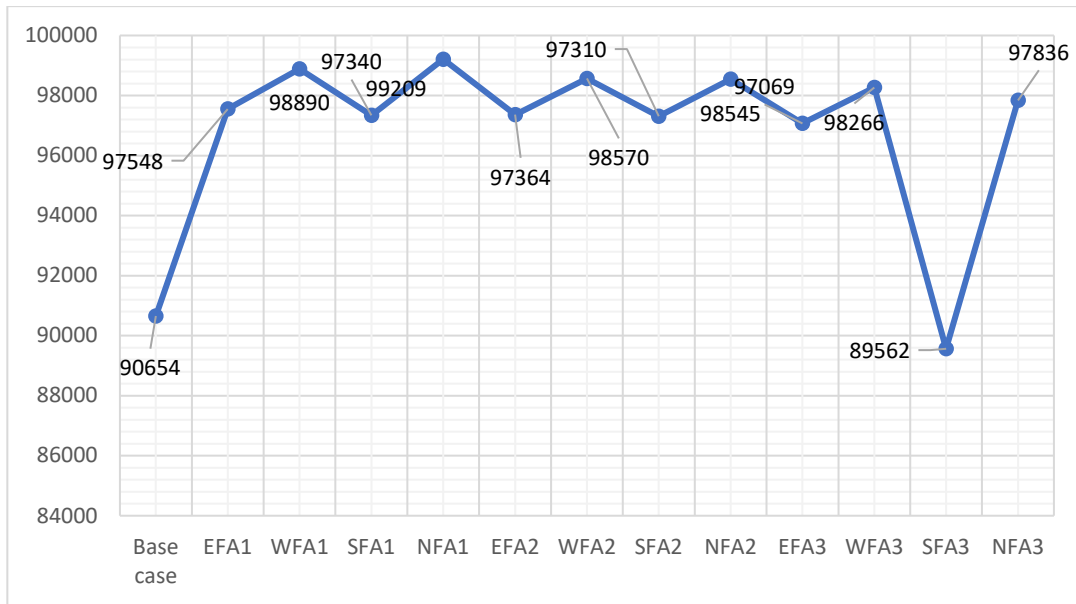

Figure 65. Annual cooling consumption for single facades simulations (kWh).

6.4.3. Short vs Long Facades

The parallel façades of building will be assigned all the alternatives individually as shown in Table 30 to examine the efficiency of combining two parallel sides i.e., North and South to East and West.

Table 30. Short vs long facades simulation scenarios.

EW	EWFA1	Façade alternative 1 applied on East and West façades
	EWFA2	Façade alternative 2 applied on East and West façades
	EWFA3	Façade alternative 3 applied on East and West façades
SN	SNFA1	Façade alternative 1 applied on South and North façades
	SNFA2	Façade alternative 2 applied on South and North façades
	SNFA3	Façade alternative 3 applied on South and North façades

In reference to sensible heating and heating consumption data summarized in Table 31 and Figure 65 and 66, there are three indications to be observed. Firstly, the south and north facades are the one to be targeted for the most energy savings

potential. Secondly, for short facades all the alternatives achieve similar savings but EWFA1 is the best one with 5.84 % decrease in heating consumption. Thirdly, for long facades the results vary and in favor of SNFA1 with of 11.07 % savings.

Table 31. Heating consumption for long and short facades simulations.

Date	Energy consumption for heating (kWh)						
	Base case	EWFA1	EWFA2	EWFA3	SNFA1	SNFA2	SNFA3
January	12313	11900	11949	11986	11241	11402	11823
February	8788	8327	8376	8398	7907	8073	8454
March	4235	3717	3704	3735	3457	3452	4062
April	429	288	285	296	249	237	408
<u>May</u>	0.01	0.01	0.01	0.01	0.01	0.01	0.01
<u>June</u>	0.00	0.00	0.00	0.00	0.00	0.00	0.00
<u>July</u>	0.00	0.00	0.00	0.00	0.00	0.00	0.00
<u>August</u>	0.00	0.00	0.00	0.00	0.00	0.00	0.00
<u>September</u>	0.00	0.00	0.00	0.00	0.00	0.00	0.00
<u>October</u>	8.3	6.66	6.63	6.78	6.23	6.16	8.08
November	145	112	119	119	100	107	129
December	7355	6986	7049	7058	6632	6743	7108
<u>Average</u>	2773	2611	2624	2633	2466	2502	2666
Annual	33273	31336	31489	31599	29592	30019	31994
Change (%)	N/A	-5.84	-5.37	-5.04	-11.07	-9.7	-3.85

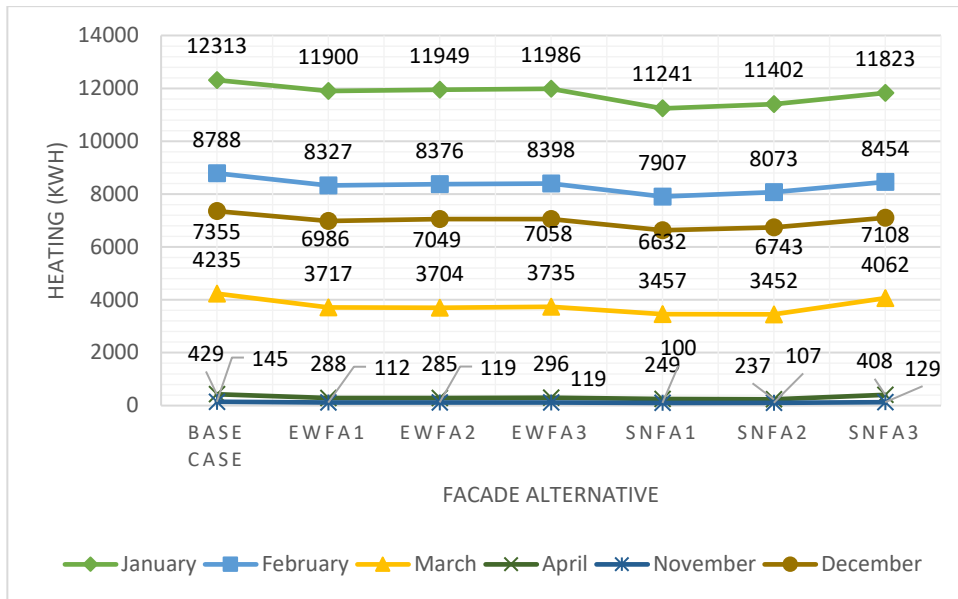

Figure 66. Monthly heating consumption for long and short façade simulations (kWh).

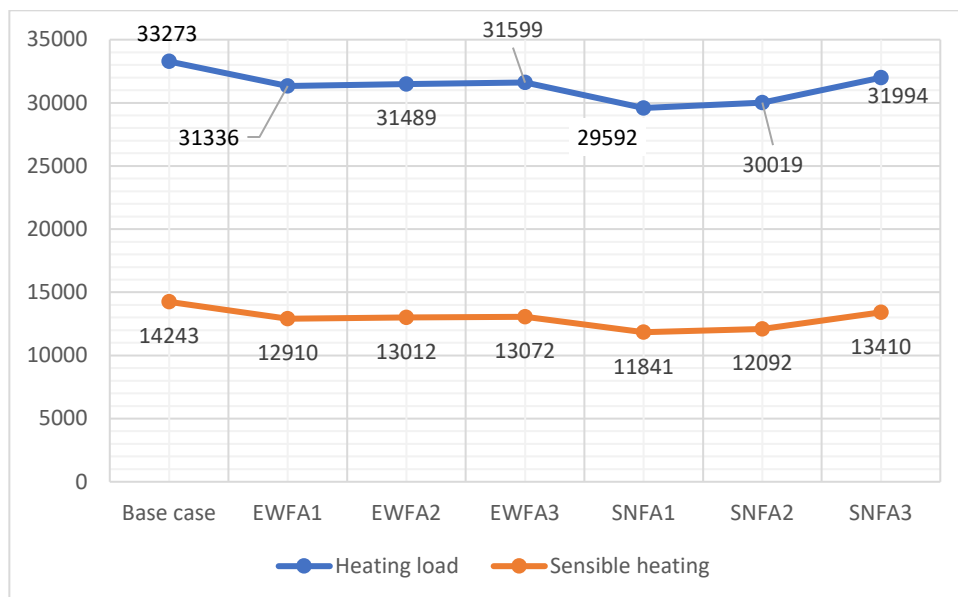

Figure 67. Annual heating data for long and short facades simulations (kWh).

In reference to sensible cooling and cooling consumption data summarized in Table 32 and Figure 68 and 69, there are three indications to be observed. Firstly, the south and north facades are the one to be targeted for the most energy savings

potential. Secondly, for short facades all the alternatives cause increasing cooling consumption. Thirdly, for long facades the results indicate increase in cooling consumption, only SNFA3 achieved 1.32 % savings.

Table 32. Cooling consumption for long and short facades simulations.

Date	Energy consumption for cooling (kWh)						
	Base case	EWFA1	EWFA2	EWFA3	SNFA1	SNFA2	SNFA3
January	4.56	6.27	5.40	5.17	7.01	4.50	3.92
February	37.1	50.2	50.0	46.4	51.1	49.8	35.8
March	113	168	177	167	184	194	103
April	1377	1734	1742	1688	1866	1896	1359
May	9744	10840	10858	10700	11112	11279	9651
June	16451	17798	17755	17627	18186	18049	16285
July	20809	22111	21814	21731	22770	21858	20610
August	21109	22529	22406	22345	22705	22396	20883
September	12437	13319	13201	13167	13505	13178	12210
October	7709	8348	8328	8245	8507	8329	7485
November	653	738	697	678	829	692	640
December	213	224	220	215	268	214	199
Average	7555	8156	8104	8051	8332	8178	7455
Annual	90654	97867	97254	96615	99989	98140	89465
Change (%)	N/A	+7.95	+7.26	+6.56	+10.28	+8.24	-1.32

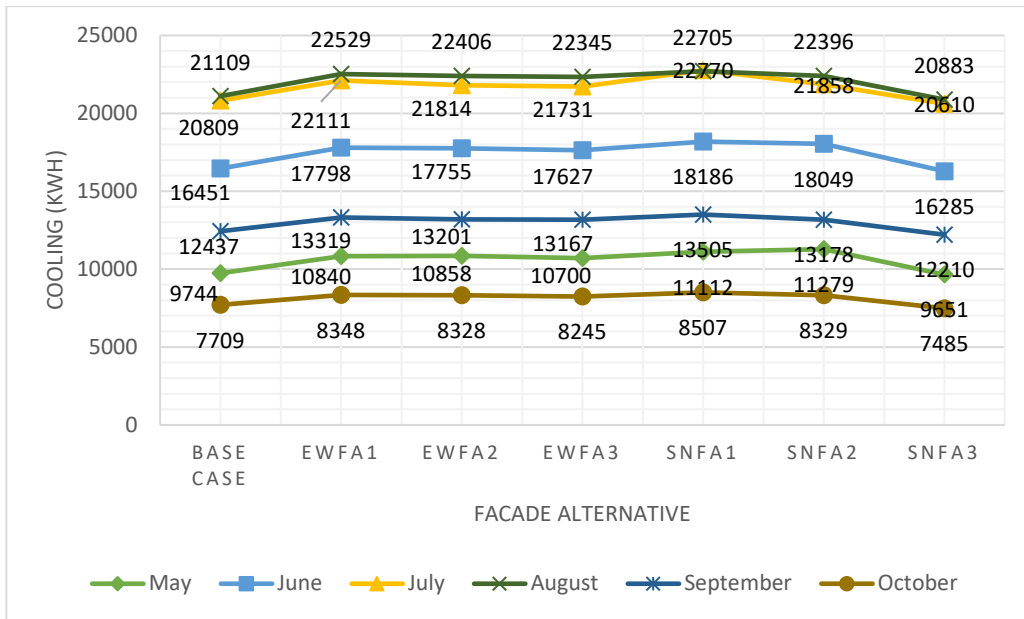

Figure 68. Monthly cooling consumption for long and short facades simulations (kWh).

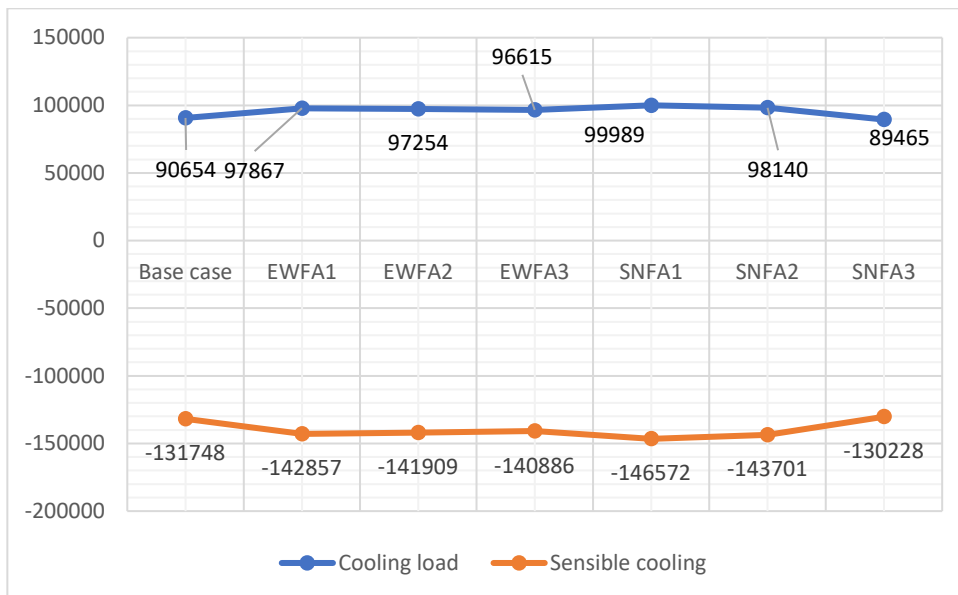

Figure 69. Annual cooling data for long and short facades simulations (kWh).

6.5. Limitation

The software employed for energy simulation i.e., DesignBuilder is unable to process two green systems as an integrated one system, thus the author was unable to perform combination scenarios. Combination scenarios such as applying two or more types of green roofs or green facades, or both are not possible in DesignBuilder. To explain, when creating a green roof material, a special feature called ‘EcoRoof’ is activated for this material. In this study the alternatives are basically ‘EcoRoof’ materials with different properties such as LAI and plant height. Once these properties change in between two ‘EcoRoof’ materials the program does not allow the simulation to run when two or more of them are assigned as construction material. The error message states, “Only one EcoRoof Material is currently allowed for all constructions.” It is marked as “severe”, and it terminates the simulation immediately.

6.6. Discussion

Simulations conducted in this study indicate that green roof and all facade scenarios have effect on heating consumption with an average monthly reduction of 6.52% and 11.72%, respectively. (Theodoridou et al., 2017) studied green systems as a building retrofitting approach in Greece, which is very similar to climate of our case study, and reported similar level of reduction (5 %) in heating consumption. (Baiceanu & Catalina, 2019) showed that the average reductions of energy consumption when retrofitting an efficient building with an extensive green roof are of 1.01 % for heating. In the meantime, other studies such as (Manso et al., 2021) and (Jayasooriya et al., 2017) were conducted in Portugal reported much higher reduction levels; i.e. 73 %, 68 %, and 71 % heating energy saving potential for extensive, semi-intensive, and intensive green roof, respectively. The literature show that the climate of the study has a high influence on the energy saving potential.

In regard to cooling consumption, this study estimated marginal reductions, that may be considerable such as 3.34% when using AFA3. Therefore, results of this study are not in well agreement with those in the literature: review articles reported 2.2–16.7% cooling consumption reduction (Besir & Cuce, 2018) (Manso et al., 2021) and 34 %-66 % cooling energy saving potential (Jayasooriya et al., 2017).

The resulted percentage change in energy consumption between the base case to the different scenarios are summarized in Figure 70 and 71 indicating reduction in minus sign. For heating, the most energy efficient alternative is FA1 (applied on all facades) but a compromise can be done by going with SNFA1. Basically, with SNFA1 similar savings are achieved by applying the façade system on south and north sides only which can be more cost effective and more feasible. For cooling, most of the alternatives increase the cooling consumption while few decrease it slightly. This is directly related to the orientation, opening-wall ratios and shape of the building. The long front façade is facing south and has high window area (22.5 %) compared to short façades, east (16.6 %) and west (6.5 %), thus leaving the MGs area to cover (77.5 %) making heat gain high. This problem has been highlighted by several studies. When reducing cooling consumption, the south and north walls were targeted because of how much they interact with the sun's altitude angles (Freewan, 2022; Sultan Qurraie & Kılıç Bakırhan, 2023). In addition, (Tong et al., 2021) highlighted that the highest cooling consumption reductions may be attained by lowering the SHGC of window glass and the window to wall ratio.

Since the systems reduce U value it is making the envelope, specifically the south facade more capable of retaining heat. That is because rooms with south-facing windows tend to be warmer since they receive more sun exposure. The most effective system seems to be extensive façade modules where scenarios AFA3, EWFA3, SFA3 and SNFA3 accomplish cooling consumption savings. This indicates that high LAI and plant height can slightly help in reducing cooling consumptions in both roof and façade, thus the intensive system is found to be the best for summer.

Overall, FA3 and RA2 will be a compromise between heating and cooling saving potential since they accomplish the second-best heating and cooling consumption reduction.

While AFA3 (applying FA3 on all Facades) accomplishes the most energy consumption reduction over the year from 123930 to 118541 kWh, for more efficient solution it is advised to implement SFA3 (applying FA3 on south façade) because it

also accomplishes good annual savings from 123930 to 122825 and impacts one façade instead of four (Figure 72). According to the calculations in Chapter 4, 1000 roof modules and 2500 for south façade considering that each cost 2.15 and \$1.65 the total cost for the most efficient option is estimated to be \$10,400. Since ARA2 and SFA3 save 12.65 % off 2773 kWh heating consumption and 1.60 % off 7555 kWh cooling consumption, ultimately saving 471.58 kWh worth \$90 on monthly average. According to the price point of \$0.190 per kWh (globalpetrolprices.com, 2023) the payback period for the proposed the most efficient solution is roughly 10 years or less while it will clean 2370 and 265 kg of CO₂ and dust particles every year (Sizirici et al., 2021).

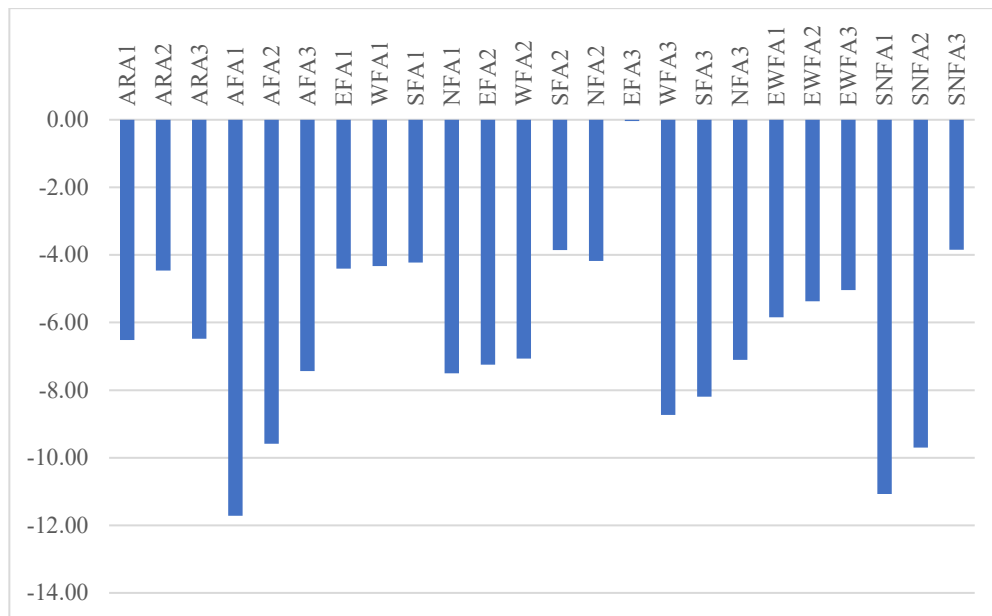

Figure 70. Savings for heating consumption percentage for all scenarios (%).

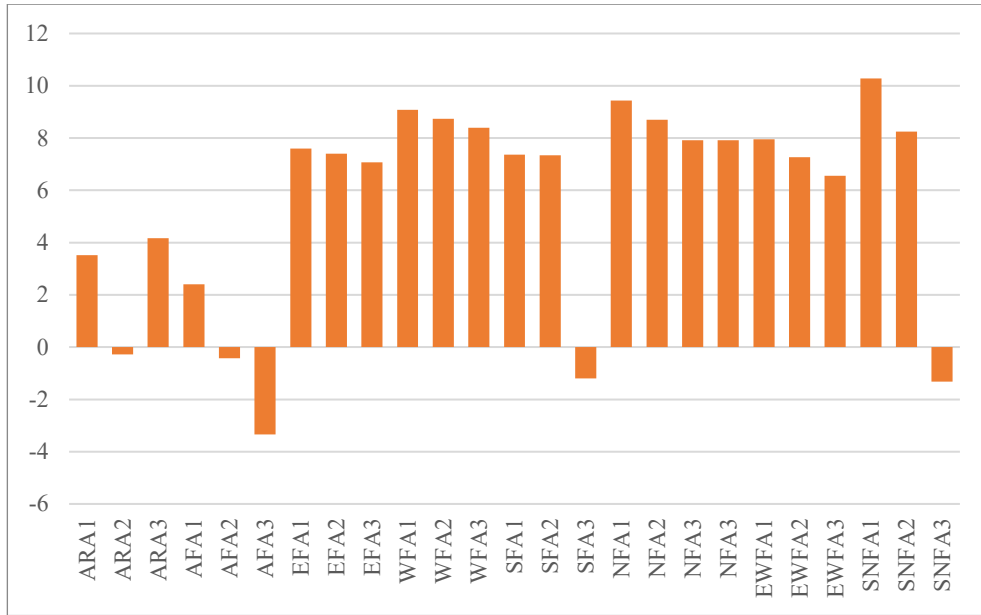

Figure 71. Savings for cooling consumption percentage for all scenarios (%).

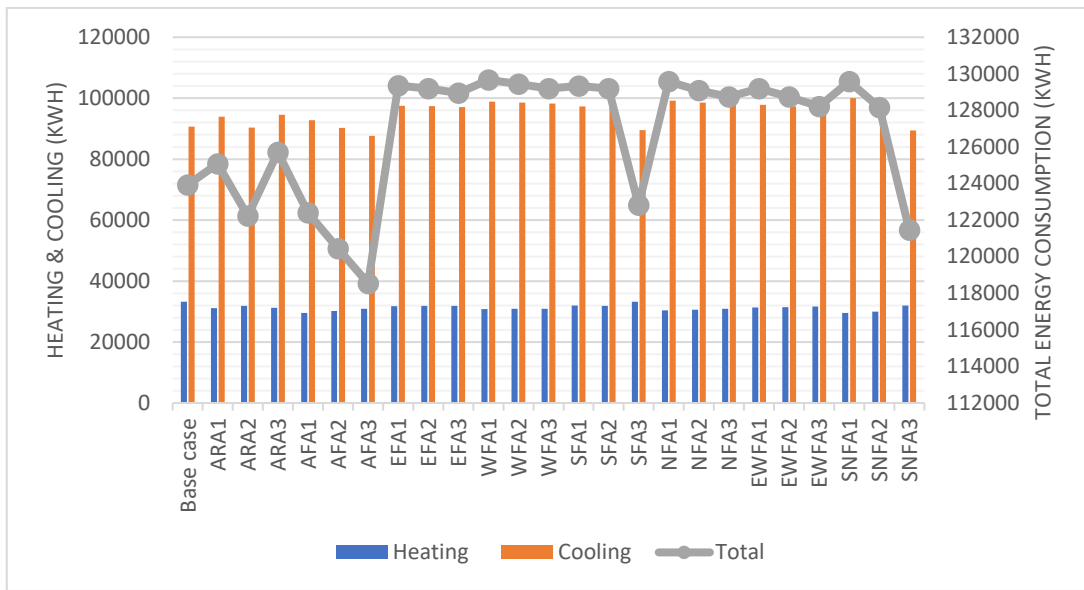

Figure 72. Heating, cooling and total consumption of all scenarios (kWh).

CHAPTER 7

CONCLUSION

The aim of this work is to assess green roof and façade modular systems as a retrofitting approach to enhance energy performance of existing structures. Findings of this study suggest that the variables examined like temperature and energy can increase dramatically in the next decade if there is not a profound movement toward retrofitting buildings. Therefore, the solution will be valid for a period of time and need to be revised in terms of cost, LCA, energy saving, etc. The case building is located in a fairly green area with low building density at the current time, thus there is no need for urban heat island analysis. Yet, research on effect of built environment on IYTE's microclimate might be useful in the future.

The LCA did not cover the building in this study. Because it targeted an existed building with realistic features that are already built. The LCA is only essential when building/proposing new approach/building which applies to the MGs not the building.

Finally, based on the findings of this study, the author is able to stipulate that green module systems can be an asset to the retrofitting strategies specially to reduce energy consumption for heating in individual buildings while the estimated marginal reductions for cooling consumptions would become an asset from a city scale energy reduction. Nevertheless, the results are specific to the location and the case study of this thesis. For similar applications, the researchers are advised to apply the methodology with customization to the conditions of the building they aim to retrofit.

Further studies can examine combining modular green systems with other strategies such as photovoltaic panels or changing glazing type, any approach that is realistically suitable for retrofitting. Examining the effect of modular green system on urban level can have optimistic result in terms of environmental benefits. Additionally, using different software can allow to conduct combination scenarios and may lead to discovering more efficient results and conducting a detailed cost analysis which can add greatly to the value of the outcome achieved by this thesis.

REFERENCES

- Abdin, A., El Deeb, K., & Am Al-Abbasi, S. (2018). EFFECT OF GREEN ROOF DESIGN ON ENERGY SAVING IN EXISTING RESIDENTIAL BUILDINGS UNDER SEMI-ARID MEDITERRANEAN CLIMATE (AMMAN AS A CASE STUDY). *JES. Journal of Engineering Sciences*, 46(6), 738-753.
- Akbari, H., & Konopacki, S. (2005). Calculating energy-saving potentials of heat-island reduction strategies. *Energy policy*, 33(6), 721-756.
- Alexandri, E., & Jones, P. (2008). Temperature decreases in an urban canyon due to green walls and green roofs in diverse climates. *Building and environment*, 43(4), 480-493.
- Altaeb, M. (2021). *Turkey finally ratified the Paris Agreement. Why now?* Middle East Institute. <https://www.mei.edu/publications/turkey-finally-ratified-paris-agreement-why-now>
- Ansys. (2023). *Granta EduPack, formerly CES EduPack, is a unique set of teaching resources to support materials education.* <https://www.ansys.com/products/materials/granta-edupack>
- ArchDaily. (2015). Chongqing Taoyuanju Community Center / Vector Architects. <https://www.archdaily.com/776435/chongqing-taoyuanju-community-center-vector-architects>
- Archello. (2010). <https://archello.com/project/oneortakoy>
- Ashby, M., Brechbühl, E., Vakhitova, T., & Vallejo, A. (2021). *Social Life-Cycle Assessment and Social Impact Audit Tool* <https://www.ansys.com/academic/educators/education-resources/paper-social-lifecycle-assessment-and-social-impact-audit-tool>
- ASHRAE. (2002). *ASHRAE GUIDELINE ASHRAE GUIDELINE.* <https://webstore.ansi.org/standards/ashrae/ashraeguideline142002>
- Ayas, C. (2020). Decarbonization Of Turkey's Economy: Long-Term Strategies And Immediate Challenges Facts, Insights and Ideas from Cross-sector Dialogue.
- Baiceanu, M., & Catalina, T. (2019). Parametric simulation study for green roof retrofit over high performance solar house prototype "EFdeN Signature". E3S Web of Conferences,
- Berardi, U. (2016). The outdoor microclimate benefits and energy saving resulting from green roofs retrofits. *Energy and Buildings*, 121, 217-229.

- Berardi, U., GhaffarianHoseini, A., & GhaffarianHoseini, A. (2014). State-of-the-art analysis of the environmental benefits of green roofs. *Applied energy*, *115*, 411-428.
- Besir, A. B., & Cuce, E. (2018). Green roofs and facades: A comprehensive review. *Renewable and Sustainable Energy Reviews*, *82*, 915-939.
- Bianchini, F., & Hewage, K. (2012). How “green” are the green roofs? Lifecycle analysis of green roof materials. *Building and environment*, *48*, 57-65.
- Birpinar, M. E. (2019). *Climate crisis: In the wake of a critical summit*. Daily Sabah. <https://www.citethisforme.com/cite/sources/websiteautociteeval>
- Blanco, J. M., Buruaga, A., Rojí, E., Cuadrado, J., & Pelaz, B. (2016). Energy assessment and optimization of perforated metal sheet double skin façades through Design Builder; A case study in Spain. *Energy and Buildings*, *111*, 326-336.
- Braun, K.-H. (2015). ZORLU CENTER ISTANBUL – GREEN SUPERLATIVES. <https://zinc-greenroof.com/press-release/zorlu-center-green-superlatives>
- Cascone, S., Evola, G., Leone, C., & Sciuto, G. (2018). Vertical greenery systems for the energy retrofitting of buildings in Mediterranean climate: a case study in Catania, Italy. IOP Conference Series: Materials Science and Engineering,
- Castleton, H., Stovin, V., Beck, S., & Davison, J. (2010). Green roofs; building energy savings and the potential for retrofit *Energy and Buildings*.
- Chafer, M., Perez, G., Coma, J., & Cabeza, L. F. (2021). A comparative life cycle assessment between green walls and green facades in the Mediterranean continental climate. *Energy and Buildings*, *249*, 111236.
- Cohen-Shacham, E., Andrade, A., Dalton, J., Dudley, N., Jones, M., Kumar, C., Maginnis, S., Maynard, S., Nelson, C. R., & Renaud, F. G. (2019). Core principles for successfully implementing and upscaling Nature-based Solutions. *Environmental Science & Policy*, *98*, 20-29.
- Coma, J., Perez, G., de Gracia, A., Burés, S., Urrestarazu, M., & Cabeza, L. F. (2017). Vertical greenery systems for energy savings in buildings: A comparative study between green walls and green facades. *Building and environment*, *111*, 228-237.
- Crawley, D. B., Lawrie, L. K., Pedersen, C. O., & Winkelmann, F. C. (2000). Energy plus: energy simulation program. *ASHRAE journal*, *42*(4), 49-56.
- Crawley, D. B., Lawrie, L. K., Winkelmann, F. C., Buhl, W. F., Huang, Y. J., Pedersen, C. O., Strand, R. K., Liesen, R. J., Fisher, D. E., & Witte, M. J.

- (2001). EnergyPlus: creating a new-generation building energy simulation program. *Energy and Buildings*, 33(4), 319-331.
- Cuce, E. (2017). Thermal regulation impact of green walls: An experimental and numerical investigation. *Applied energy*, 194, 247-254.
- Curry, A. (2019). *Pros and Cons of green roof system*.
<https://www.leaffilter.com/blog/home-exterior/roofing-gutters/green-roof-pros-cons/>
- Dabous, S. A., Ghenai, C., Shanableh, A., & Al-Khayyat, G. (2017). Comparison between major repair and replacement options for a bridge deck life cycle assessment: A case study. MATEC Web of Conferences,
- Dachbegrünungen. (2018). *Guidelines for the planning, Construction and Maintenance of Green Roofing*. L. D. a. L. R. Society.
- DesignBuilder. (2023). Green Roof.
<https://designbuilder.co.uk/helpv7.0/Content/GreenRoof.htm>
- Dihkan, M., Karsli, F., Guneroglu, N., & Guneroglu, A. (2018). Evaluation of urban heat island effect in Turkey. *Arabian Journal of Geosciences*, 11, 1-20.
- Eisabegloo, A., Haghshenas, M., & Borzoui, A. (2016). Comparing the results of thermal simulation of rasoulilian house in Yazd by design builder software, with experimental data. *Iran University of Science & Technology*, 26(2), 121-130.
- Elbir, T., Müezzinoğlu, A., & Bayram, A. (2000). Evaluation of some air pollution indicators in Turkey. *Environment International*, 26(1-2), 5-10.
- ELİNÇ, Z. K., KAYA, L. G., & ELİNÇ, H. (2013). Analysis Of Contribution Of Vertical Gardens To Urban Sustainability: The Case Study Of Antalya City, Turkey. *İnönü Üniversitesi Sanat ve Tasarım Dergisi*, 3(7).
- Emilsson, T. (2008). Vegetation development on extensive vegetated green roofs: Influence of substrate composition, establishment method and species mix. *Ecological engineering*, 33(3-4), 265-277.
- European Environment Agency. (2015). *Air quality in Europe — 2015 report*.
<https://www.eea.europa.eu/publications/air-quality-in-europe-2015>
- Feng, H., & Hewage, K. (2014). Lifecycle assessment of living walls: air purification and energy performance. *Journal of Cleaner Production*, 69, 91-99.
- Ferrante, P., La Gennusa, M., Peri, G., Rizzo, G., & Scaccianoce, G. (2016). Vegetation growth parameters and leaf temperature: Experimental results from a six plots green roofs' system. *Energy*, 115, 1723-1732.

- Frankenstein, S., & Koenig, G. G. (2004). Fast all-season soil strength (FASST).
- Freewan, A. A. (2022). Energy-Efficient Solutions Depending on Building Forms Design with Tilted South and North Facades. *Buildings*, 12(6), 753.
- globalpetrolprices.com. (2023). *Turkey electricity prices*.
https://www.globalpetrolprices.com/Turkey/electricity_prices/
- Gobron, N. (2005). *LEAF AREA INDEX (LAI)*.
- Greening Solution. (2023). *Green Wall Trays*. <https://www.greening-solution.com/green-wall-trays/>
- Hamade, R., Hadchiti, R., & Ammouri, A. (2020). Making the environmental case for reusable PET bottles. *Procedia Manufacturing*, 43, 201-207.
- He, Y., Yu, H., Dong, N., & Ye, H. (2016). Thermal and energy performance assessment of extensive green roof in summer: A case study of a lightweight building in Shanghai. *Energy and Buildings*, 127, 762-773.
- Hejl, M., Mohapl, M., & Bříza, L. (2020). Modular green roofs and their usage in the world. *International Journal of Engineering Research in Africa*,
- Hien, W. N., Yok, T. P., & Yu, C. (2007). Study of thermal performance of extensive rooftop greenery systems in the tropical climate. *Building and environment*, 42(1), 25-54.
- Hoelscher, M.-T., Nehls, T., Jänicke, B., & Wessolek, G. (2016). Quantifying cooling effects of facade greening: Shading, transpiration and insulation. *Energy and Buildings*, 114, 283-290.
- Hui, S. C., & Chan, H.-M. (2008). Development of modular green roofs for high-density urban cities. *World Green Roof Congress*,
- Hussien, A., Jannat, N., Mushtaha, E., & Al-Shammaa, A. (2023). A holistic plan of flat roof to green-roof conversion: Towards a sustainable built environment. *Ecological engineering*, 190, 106925.
- Ibrahim, I. A., & Al-Chaderchi, B. M. (2022). CONTRIBUTION OF THE BIOPHILIC DESIGN APPROACH TO THE UN SUSTAINABLE DEVELOPMENT GOALS. *Eco-Architecture IX: Harmonisation between Architecture and Nature*, 210, 115.
- Im, P., New, J. R., & Joe, J. (2019). *Empirical validation of building energy modeling using flexible research platform*. t. I. I. C. E. o. B. S. 2019.
- Jaffal, I., Ouldboukhitine, S.-E., & Belarbi, R. (2012). A comprehensive study of the impact of green roofs on building energy performance. *Renewable energy*, 43, 157-164.

- Jayasooriya, V., Ng, A., Muthukumaran, S., & Perera, B. (2017). Green infrastructure practices for improvement of urban air quality. *Urban Forestry & Urban Greening*, 21, 34-47.
- Jena, T., & Kaewunruen, S. (2021). Life cycle sustainability assessments of an innovative FRP composite footbridge. *Sustainability*, 13(23), 13000.
- Kamel, E., & Memari, A. M. (2022). Residential Building Envelope Energy Retrofit Methods, Simulation Tools, and Example Projects: A Review of the Literature. *Buildings*, 12(7), 954.
- Karachaliou, P., Santamouris, M., & Pangelou, H. (2016). Experimental and numerical analysis of the energy performance of a large scale intensive green roof system installed on an office building in Athens. *Energy and Buildings*, 114, 256-264.
- Kim, J., Hong, T., Jeong, J., Koo, C., & Jeong, K. (2016). An optimization model for selecting the optimal green systems by considering the thermal comfort and energy consumption. *Applied energy*, 169, 682-695.
- Korol, E., & Shushunova, N. (2016). Benefits of a modular green roof technology. *Procedia Engineering*, 161, 1820-1826.
- Korol, E., & Shushunova, N. (2017). Green roofs: standardization and quality control of processes in green construction. MATEC Web of Conferences,
- Korol, E., & Shushunova, N. (2018). Modular green roofs in urban ecospace. In *Landscape Architecture-The Sense of Places, Models and Applications*. IntechOpen.
- Kosareo, L., & Ries, R. (2007). Comparative environmental life cycle assessment of green roofs. *Building and environment*, 42(7), 2606-2613.
- Land8. (2016). *10 of the Best Green Roof Designs in the World*. <https://land8.com/10-of-the-best-green-roof-designs-in-the-world/#:~:text=Orto%20fra%20i%20cortili%20is,in%20yellow%20and%20purplish%20blue>
- Li, W. C., & Yeung, K. K. A. (2014). A comprehensive study of green roof performance from environmental perspective. *International Journal of Sustainable Built Environment*, 3(1), 127-134.
- Lin, B.-S., Yu, C.-C., Su, A.-T., & Lin, Y.-J. (2013). Impact of climatic conditions on the thermal effectiveness of an extensive green roof. *Building and environment*, 67, 26-33.
- Loiola, C., Mary, W., & da Silva, L. P. (2019). Hydrological performance of modular-tray green roof systems for increasing the resilience of mega-cities to climate change. *Journal of Hydrology*, 573, 1057-1066.

- Luna-Tintos, J., Cobreros, C., López-Escamilla, Á., Herrera-Limones, R., & Torres-García, M. (2020). Methodology to evaluate the embodied primary energy and CO₂ production at each stage of the life cycle of prefabricated structural systems: the case of the solar decathlon competition. *Energies*, *13*(17), 4311.
- Mankuri, D. P. A. *Investigation of the roof and vertical green structures and a sample application to Erbil Fen Bilimleri Enstitüsü*].
- Manso, M., & Castro-Gomes, J. (2015). Green wall systems: A review of their characteristics. *Renewable and Sustainable Energy Reviews*, *41*, 863-871.
- Manso, M., & Castro-Gomes, J. (2016). Thermal analysis of a new modular system for green walls. *Journal of Building Engineering*, *7*, 53-62.
- Manso, M., Teotónio, I., Silva, C. M., & Cruz, C. O. (2021). Green roof and green wall benefits and costs: A review of the quantitative evidence. *Renewable and Sustainable Energy Reviews*, *135*, 110111.
- Marques, A. C. (2013). Sustainability in design education: Introduction of life cycle assessment (LCA). The 3rd World Sustainability Forum,
- Medl, A., Stangl, R., & Florineth, F. (2017). Vertical greening systems—A review on recent technologies and research advancement. *Building and environment*, *125*, 227-239.
- Meteonorm Software. (2006). Worldwide irradiation data.
<https://meteonorm.com/en/>
- Nardini, A., Andri, S., & Crasso, M. (2012). Influence of substrate depth and vegetation type on temperature and water runoff mitigation by extensive green roofs: shrubs versus herbaceous plants. *Urban Ecosystems*, *15*, 697-708.
- ODS. (2022). *FACELIFT TO FAÇADE WITH SUSTAINABLE GREEN WALL*.
<https://www.outdoordesign.com.au/news-info/facelift-to-faade-with-sustainable-green-wall/9412.htm>
- one nine elms. (2022). *How Many Buildings Are There in the World 2022*.
<https://www.onenineelms.co.uk/2022/09/13/how-many-buildings-are-there-in-the-world-2022/#:~:text=There%20are%20an%20estimated%20100,grow%20in%20the%20coming%20years>
- Ormond, V. (2020). *15 green building hotspots around the world*. Knight Frank.
<https://www.knightfrank.com/research/article/2020-11-23-15-green-building-hotspots-around-the-world#:~:text=There%20are%20more%20than%20120%2C000,cities%20should%20they%20consider%20first%3F>

- Ottel , M., Perini, K., Fraaij, A., Haas, E., & Raiteri, R. (2011). Comparative life cycle analysis for green faades and living wall systems. *Energy and Buildings*, 43(12), 3419-3429.
- Ouldboukhitine, S.-E., Belarbi, R., & Djedjig, R. (2012). Characterization of green roof components: Measurements of thermal and hydrological properties. *Building and environment*, 56, 78-85.
- Pawar, B. S., & Kanade, G. (2018). Energy optimization of building using design builder software. *International Journal of New Technology and Research*, 4(1), 263152.
- P rez, G., Rinc n, L., Vila, A., Gonz lez, J. M., & Cabeza, L. F. (2011). Behaviour of green facades in Mediterranean Continental climate. *Energy conversion and management*, 52(4), 1861-1867.
- Perini, K. (2013). Retrofitting with vegetation recent building heritage applying a design tool—the case study of a school building. *Frontiers of Architectural Research*, 2(3), 267-277.
- Perini, K., Ottel , M., Haas, E., & Raiteri, R. (2011). Greening the building envelope, faade greening and living wall systems. *Open Journal of Ecology*, 1(01), 1.
- Pollini, B., & Rognoli, V. (2021). Early-stage material selection based on life cycle approach: tools, obstacles and opportunities for design. *Sustainable Production and Consumption*, 28, 1130-1139.
- REN21. (2020). *Renewables 2020 Global Status Report*. <https://www.ren21.net/gsr-2020/>
- Rosasco, P., & Perini, K. (2018). Evaluating the economic sustainability of a vertical greening system: A Cost-Benefit Analysis of a pilot project in mediterranean area. *Building and environment*, 142, 524-533.
- Rosasco, P., & Perini, K. (2019). Selection of (green) roof systems: A sustainability-based multi-criteria analysis. *Buildings*, 9(5), 134.
- Rosenzweig, C., Solecki, W., & Slosberg, R. (2006). Mitigating New York City’s heat island with urban forestry, living roofs, and light surfaces. *A report to the New York State Energy Research and Development Authority*.
- Rowe, D. B. (2011). Green roofs as a means of pollution abatement. *Environmental pollution*, 159(8-9), 2100-2110.
- SABAMEHR, T. (2019). MICROCLIMATIC EFFECTS OF GREEN ROOF APPLICATIONS IN DENSE URBAN AREAS.
- Sailor, D. J. (2008). A green roof model for building energy simulation programs. *Energy and Buildings*, 40(8), 1466-1478.

- Samu, H. (2016). *Greenox: Turkey's first vertical forest*.
<https://www.construction21.org/articles/h/greenox-turkey-s-first-vertical-forest.html>
- Santamouris, M., Pavlou, C., Doukas, P., Mihalakakou, G., Synnefa, A., Hatzibiros, A., & Patargias, P. (2007). Investigating and analysing the energy and environmental performance of an experimental green roof system installed in a nursery school building in Athens, Greece. *Energy*, 32(9), 1781-1788.
- Santi, G., Bertolazzi, A., Leporelli, E., Turrini, U., & Croatto, G. (2020). Green systems integrated to the building envelope: Strategies and technical solution for the Italian case. *Sustainability*, 12(11), 4615.
- Seddon, N., Chausson, A., Berry, P., Girardin, C. A., Smith, A., & Turner, B. (2020). Understanding the value and limits of nature-based solutions to climate change and other global challenges. *Philosophical Transactions of the Royal Society B*, 375(1794), 20190120.
- Sedum Green Roof. (2022). *How to install a green roof*.
- Sfakianaki, A., Pagalou, E., Pavlou, K., Santamouris, M., & Assimakopoulos, M. (2009). Theoretical and experimental analysis of the thermal behaviour of a green roof system installed in two residential buildings in Athens, Greece. *International Journal of Energy Research*, 33(12), 1059-1069.
- Sheweika, S., & Magdy, A. N. (2011). The living walls as an approach for a healthy urban environment. *Energy Procedia*, 6, 592-599.
- Silva, C. M., Gomes, M. G., & Silva, M. (2016). Green roofs energy performance in Mediterranean climate. *Energy and Buildings*, 116, 318-325.
- Sizirici, B., Fseha, Y., Cho, C.-S., Yildiz, I., & Byon, Y.-J. (2021). A review of carbon footprint reduction in construction industry, from design to operation. *Materials*, 14(20), 6094.
- Spala, A., Bagiorgas, H., Assimakopoulos, M., Kalavrouziotis, J., Matthopoulos, D., & Mihalakakou, G. (2008). On the green roof system. Selection, state of the art and energy potential investigation of a system installed in an office building in Athens, Greece. *Renewable energy*, 33(1), 173-177.
- Sultan Qurraie, B., & Kılıç Bakırhan, E. (2023). Evaluation of facade systems in different climate zones regarding energy, comfort, emission, and cost. *Arab Journal of Basic and Applied Sciences*, 30(1), 123-136.
- Tbayshat, N. R. H. The challenges and opportunities of living wall systems integration into buildings facades in Amman.
- Theodoridou, I., Karteris, M., Mallinis, G., Tsiros, E., & Karteris, A. (2017). Assessing the benefits from retrofitting green roofs in mediterranean, using

environmental modelling, GIS and very high spatial resolution remote sensing data: the example of Thessaloniki, Greece. *Procedia environmental sciences*, 38, 530-537.

Thomson Reuters Foundation. (2019). FACTBOX-12 global initiatives to beat back climate threats.

<https://www.citethisforme.com/cite/sources/websiteautociteeval>

Timperley, J. (2021). *The Carbon Brief Profile: Turkey*.

<https://www.carbonbrief.org/carbon-brief-profile-turkey/>

Tong, S., Wen, J., Wong, N. H., & Tan, E. (2021). Impact of façade design on indoor air temperatures and cooling consumptions in residential buildings in the tropical climate. *Energy and Buildings*, 243, 110972.

United Nations. (2021). *National inventory reports (NIR)*.

<https://unfccc.int/documents/271544>

urbanNext. (2023). *One Central Park*. <https://urbannext.net/one-central-park/>.

Velazquez, L. (2014). *Greenwall Project of the Week for January 13, 2014: Musée du quai Branly*. <https://www.greenroofs.com/2014/01/14/greenwall-project-of-the-week-for-january-13-2014-musee-du-quai-branly/>

Vijayaraghavan, K. (2016). Green roofs: A critical review on the role of components, benefits, limitations and trends. *Renewable and Sustainable Energy Reviews*, 57, 740-752.

Vox, G., Blanco, I., & Schettini, E. (2018). Green façades to control wall surface temperature in buildings. *Building and environment*, 129, 154-166.

Wasilowski, H. A., & Reinhart, C. F. (2009). Modelling an existing building in DesignBuilder/EnergyPlus: custom versus default inputs. Eleventh International IBPSA Conference,

WorldWeatherOnline.com. *Izmir Annual Weather Averages*.

<https://www.worldweatheronline.com/izmir-weather-averages/izmir/tr.aspx>

Yang, J., Yu, Q., & Gong, P. (2008). Quantifying air pollution removal by green roofs in Chicago. *Atmospheric environment*, 42(31), 7266-7273.

Yıldız, Y. (2016). Impacts of climate change on heating and cooling consumptions in residential buildings.

YU, C. (2006). *THE INTERVENTION OF PLANTS IN THE CONFLICTS BETWEEN BUILDINGS AND CLIMATE*

Zeng, C., Bai, X., Sun, L., Zhang, Y., & Yuan, Y. (2017). Optimal parameters of green roofs in representative cities of four climate zones in China: A simulation study. *Energy and Buildings*, 150, 118-131.

Zhang, L. (2014). Simulation analysis of built environment based on design builder software. *Applied Mechanics and Materials*,